



UNIVERSITY
OF WOLLONGONG
AUSTRALIA

University of Wollongong
Research Online

Faculty of Informatics - Papers (Archive)

Faculty of Engineering and Information Sciences

2011

Understanding the conducting states of active and passive switches in an inverter circuit used for power system applications

Danny Sutanto

University of Wollongong, soetanto@uow.edu.au

B.P. Divakar

K.W.E. Cheng

Publication Details

Divakar, B. P., Cheng, K. W. E. & Sutanto, D. (2011). Understanding the conducting states of active and passive switches in an inverter circuit used for power system applications. *Power Electronics Systems and Applications (PESA) 2011 4th International Conference* (pp. 1-6). Australia: IEEE.

Research Online is the open access institutional repository for the University of Wollongong. For further information contact the UOW Library:
research-pubs@uow.edu.au

Understanding the conducting states of active and passive switches in an inverter circuit used for power system applications

Abstract

Bi-directional inverter circuits are commonly used in many applications in power systems, such as in FACTS devices, energy storage systems and active power filters. Many power engineering students however find it difficult to understand the conducting states of the active switches (transistors, IGBTs) and the passive switches (the antiparallel diodes connected across the active switches). It seems a mystery to them that power can flow from a lower voltage ac system to a higher voltage dc system to charge the energy storage system. This paper proposes a simple chart that intuitively explains how to determine the states (either conducting or non-conducting) of the active and passive switches of an inverter. The flowchart helps students to understand the cyclic changes in the topology of the circuit in a switching cycle. The flowchart by nature is general and can be used for any type of control methods such as sinusoidal PWM and hysteresis control. The application of the use of this chart is also discussed for a battery energy storage system.

Keywords

Understanding, conducting, states, active, passive, switches, inverter, circuit, used, for, power, system, applications

Disciplines

Physical Sciences and Mathematics

Publication Details

Divakar, B. P., Cheng, K. W. E. & Sutanto, D. (2011). Understanding the conducting states of active and passive switches in an inverter circuit used for power system applications. *Power Electronics Systems and Applications (PESA) 2011 4th International Conference* (pp. 1-6). Australia: IEEE.

Understanding the Conducting States of Active and Passive Switches in an Inverter Circuit Used for Power System Applications

B.P. Divakar¹, K.W.E. Cheng² and D. Sutanto²

¹EEE Department, REVA Institute of Technology and Management, Kattigenahalli, Bangalore, INDIA
Email: eebpdiva@hotmail.com

²Department of Electrical Engineering, The Hong Kong Polytechnic University, Hong Kong

Abstract—Bi-directional inverter circuits are commonly used in many applications in power systems, such as in FACTS devices, energy storage systems and active power filters. Many power engineering students however find it difficult to understand the conducting states of the active switches (transistors, IGBTs) and the passive switches (the anti-parallel diodes connected across the active switches). It seems a mystery to them that power can flow from a lower voltage ac system to a higher voltage dc system to charge the energy storage system. This paper proposes a simple chart that intuitively explains how to determine the states (either conducting or non-conducting) of the active and passive switches of an inverter. The flowchart helps students to understand the cyclic changes in the topology of the circuit in a switching cycle. The flowchart by nature is general and can be used for any type of control methods such as sinusoidal PWM and hysteresis control. The application of the use of this chart is also discussed for a battery energy storage system.

Keywords—Educational tools, Inverter operation, Battery Energy Storage System, Energy Storage System, active filter.

I. INTRODUCTION

In recent times, inverters have found its way into many fields of power system research works, particularly in the area of the applications of power electronics for power system applications, such as FACTS, Energy Storage Systems and active filters.

The undergraduate students usually learn the basic operation of an inverter circuit as well as traditional control of inverter by sinusoidal pulse width modulation (SPWM) and hysteresis techniques [1]. It is known that a series of gating signals are generated from these control methods. In a single phase inverter controlled by sinusoidal pulse width modulation (SPWM), a reference sinusoidal signal is compared with a triangular signal whose frequency is equal to the switching frequency of the circuit to generate gate signals for the switches. In some applications, due to its simplicity, hysteresis control is often applied instead of SPWM. In the hysteresis type of control, the output current can be made to follow any reference signal within a small error band known as hysteresis.

Normally students carry out the analysis of the power electronic circuit using a simulation tool (such as PSPICE) and observe the waveforms in one ac fundamental frequency as prescribed in an undergraduate syllabus. Although students know the operation of the basic inverter circuit, many find it difficult to visualize the topological changes occurring in the circuit during every switching

instant. Students often find it difficult to understand the fundamental concept behind some aspects of the operation of the circuit, such as what is the path taken by the current in the circuit following a switching operation, and how the dc supply at a higher potential can be charged from a low voltage ac source.

The reason for their inability to find answers for such queries is that they do not consider the problem as a normal circuit problem and that the problem can be solved by applying the basic circuit theory. Students are often mystified by the various switching operations and fail to apply the knowledge, which they have learnt before in solving the problem before them.

Having identified some of the weaknesses of our past students, we decided to address the issue by including a tutorial in our Power Electronics course. The main objectives of the tutorial are a) to train students to identify the conducting states of the active/passive switches of an inverter controlled by any PWM or hysteresis control and b) to help them extract information from PSPICE simulation to understand the topological changes in every switching operation. The tutorial mainly consists of a) a flowchart-aided explanation to identify the conducting states of switches in a basic inverter circuit, and b) how to apply the flow chart as a means of understanding the operation of the inverter in a battery energy storage system (BESS) [2].

The study of the topological changes in a circuit is very crucial for students pursuing the area of the development of new topologies in their later academical career. For example, the design of a topology with zero switching loss (soft-switching) involves placing a sub-circuit consisting of an active/passive switches with a resonant network at appropriate position within the basic circuit and then switching them at the correct instants so as to achieve loss-less switching [3-4]. In order to design such circuits, a designer must have a thorough knowledge of the switching status of every switch in a basic inverter circuit in order to trace the path of the current at any given instant. Once the path of the current is known, one will be able to divert the current using a sub-circuit to achieve loss-less transition. PSPICE is an excellent tool to gain insight into the operation of the circuit. However, students must be trained to interpret the results from PSPICE simulation; otherwise the results are of little help to students.

The motivation for the current paper comes from dealing

with many final year students carrying out their project involving the use of power electronics for use in power system. In order to explain the operation of the circuit, the following points must be made clear to the students:

- what are the switching sequences
- whether the current is or is not flowing in the switch when it is conducting
- when will the current flow through the diode
- what happens to the current in the switch when it is ON and the diode is conducting

It is very difficult but not impossible to address the above issues in a classroom. We believe that an explanation can be made very effective provided it is simple to understand. The topic of the paper presents a methodical approach to help students to identify the switching states of the devices in an inverter circuit by interpreting the PSPICE simulation results.

The paper initially gives the development of the proposed flow chart to identify the switching states of the inverter circuit. The paper then describes the use of this chart to explain the topological changes of the inverter used in a battery energy storage system.

II. CIRCUIT DESCRIPTION

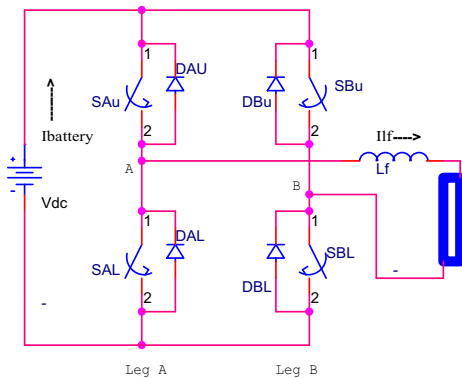

Fig. 1: inverter circuit

A single phase inverter shown in Figure 1 consists of four switches and four diodes. The inverter is connected between a dc source represented by a battery (V_{dc}) and the load through an inductor, L_f . The inverter circuit can be considered to be a parallel combination of two legs A and B. Two switches are connected in series in each leg along with their respective diodes. The switches are named according to the leg they belong to and their position in the leg. In doing so, the switch in the upper position of leg A is designated as S_{AU} . Similarly, the diode across S_{AU} is represented as D_{AU} . Two complimentary gating signals generated by PWM or hysteresis method are applied to the gates of the switches. In the bipolar type of control, S_{AU} and S_{BL} receive the same signal while S_{AL} and S_{BU} receive the complimentary signal.

Before proceeding further, let us make some observations from Fig.1. The reference direction of the flow of the battery current in Figure 1 is assumed to be positive. We can see that, for $V(A,B)$ to be positive the following pairs

of devices must be in conduction:

$$S_{AU} \ \& \ S_{BL} \ \text{or} \ D_{AU} \ \& \ D_{BL}$$

We can also see that, if $S_{AU} \ \& \ S_{BL}$ are in conduction a positive current from the battery flows through L_f contributing to a positive inductor current. By the same argument, we can say that, $D_{AU} \ \& \ D_{BL}$ can conduct only to deliver current from the load side to the dc source. This is possible only when the current is flowing in the reverse direction through L_f . In other words, a negative current in the inductor flows through $D_{AU} \ \& \ D_{BL}$ to the dc source contributing to a negative dc current.

Similarly, for $V(A,B)$ to be negative, the following pairs of devices must conduct:

$$S_{BU} \ \& \ S_{AL} \ \text{or} \ D_{BU} \ \& \ D_{AL}$$

As before let us analyze the two cases one at a time. If $S_{BU} \ \& \ S_{AL}$ are conducting, the positive terminal of the battery is connected to the node "B" while its negative terminal is connected to the node "A". As a result, the current from the battery enters at node "B" and flows through the inductor from right to left before making its exit to the negative terminal via node "A". So we can say that when $V(A,B)$ is negative and $S_{BU} \ \& \ S_{AL}$ are in conduction, the battery current is positive while the inductor current I_{Lf} is negative. On the other hand, when D_{AL} and D_{BU} are in conduction, the path taken by the current is D_{BU} - battery - D_{AL} - L_f - load - D_{BU} . Now we can say that when $V(A,B)$ is negative and $D_{BU} \ \& \ D_{AL}$ are in conduction, the battery current is negative while the current in the inductor is positive.

From the above discussion, we can conclude that, to determine the states of the devices we require to examine the waveforms of $V(A,B)$, dc current & inductor current. The discussion is summarized in the Table I, which also helps in formulating some rules to aid the detection of states of the devices.

A. Rules governing the switching states of the devices.

Rule 1: Current through two switches is possible only when the battery current is positive

Rule 2: Current through two diodes is possible only when the battery current is negative.

In an inverter with a unipolar type of control (where the upper & lower switches in the complimentary legs receive separate signals), the following rule must also be included:

Rule 3: $V(A,B) = 0 \rightarrow$ input current = 0; which means one diode & one switch on the same side (either upper or lower) of either legs are in conduction.

Table 1: Conducting States

| Devices in conduction | $V(A,B)$ | dc current (Battery current) | Inductor current (I_{lf}) |
|-----------------------|----------|------------------------------|-------------------------------|
|-----------------------|----------|------------------------------|-------------------------------|

| | | | |
|--------------------|---|--------------------|----------------------|
| $S_{AU} \& S_{BL}$ | + | + | + |
| | | (Current leaving) | (From left to right) |
| $S_{AL} \& S_{BU}$ | - | + | - |
| $D_{AU} \& D_{BL}$ | + | - | - |
| | | (Current entering) | (From right to left) |
| $D_{BU} \& D_{AL}$ | - | - | + |

A more meaningful interpretation of the contents of the Table is presented in the form of a chart as shown below.

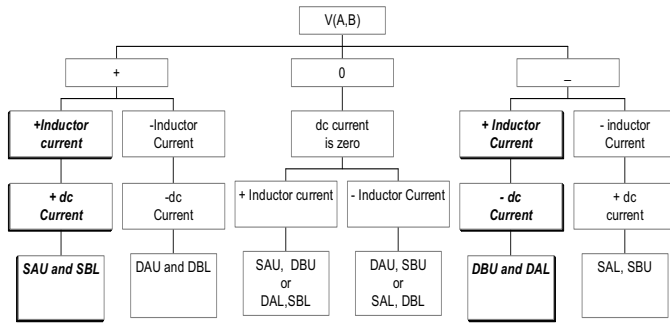

Fig. 2: Flow Chart to determine the conducting states of switches

The flow chart helps students to determine the conducting states of the switches at any given instant. Students first have to find the polarity of $V(A,B)$ and the direction of current in L_f and then look in the flow chart to determine the devices that are in conduction. This will enable them to draw the equivalent circuit and carry out mathematical analysis.

How the flow chart can be used as a tool to explain the topological changes in an inverter circuit used in a battery energy storage system is described in the next section.

III. APPLICATION OF THE USE OF THE CHART: BATTERY ENERGY STORAGE SYSTEMS

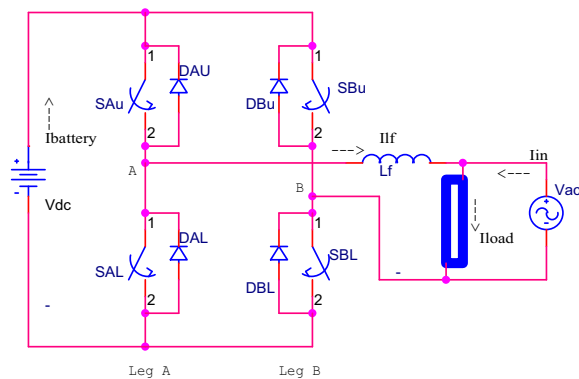

Fig. 3: Battery Energy Storage System

The use of flowchart-aided explanation will be clear by considering an example in which an inverter circuit is used in a battery energy storage system as shown in Figure 3. In such a system, the inverter is connected between a battery source and an ac source and the operation of the switches are controlled such that the current from the ac source can be maintained sinusoidal at any desired value despite any

changes in the load current. Therefore, the battery basically supplies the difference between the ac source and the load current. The battery voltage is usually much higher than the rms voltage of the ac source. Such a system can provide load leveling and active filtering. For load leveling purpose, the magnitude of the controlled ac source current is usually set at the specified maximum demand (MD) value, which is charged by the utility monthly irrespective of how often the load actually reaches this maximum demand or how long does the maximum demand lasts. It is therefore useful to reduce this value as low as practically possible using the battery energy storage system (BESS). When the load exceeds the specified MD value, then the BESS will provide the difference between the actual load and the MD value. Our experience shows that it is easy for the student to visualize this operation. Since the battery voltage is higher than the maximum value of the ac voltage the battery can supply the extra demand. However, at night, where the load is usually very low, the setting for the ac current source is usually set higher than the minimum load so that the battery can be charged at off-peak rate in preparation to supply the load during peak load. Interestingly enough, the students find it difficult to understand how the ac system (where the maximum value of the voltage is lower than the battery voltage) can possibly cause current to flow back to the battery to charge it. In every battery energy storage project that we had allocated to the students, this has always been a question that will be posed by the student.

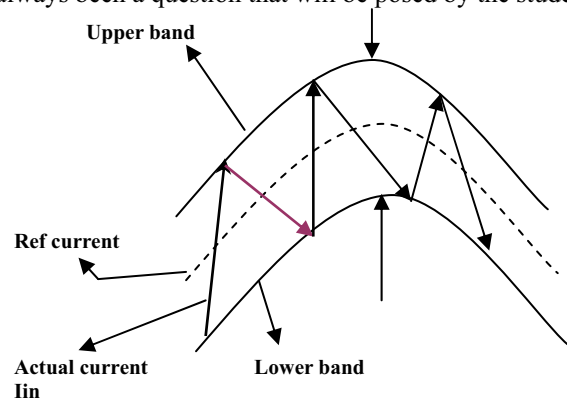

Fig. 4: Hysteresis window

In this example, the well known hysteresis [1] control method is adopted to generate the gating signals for the active switches. Accordingly, a reference sinusoidal signal is compared with the mains ac input current (I_{in}) and the error between them is restricted between a positive and a negative limit which is generally known as the hysteresis band. As a result the input current will follow the sinusoidal reference signal with a small ripple depending on the width of the hysteresis window as shown in Figure 4. For example, if the actual current I_{in} exceeds the reference value by an amount equal to the hysteresis limit Δh , the control circuit sends signals to turn on S_{AU} and S_{BL} in order to ramp up the current in L_f . (because the battery voltage magnitude is always higher than the instantaneous voltage of the ac voltage, $V_{dc} > V_{ac \text{ rms}}$) Since $I_{in} + I_{Lf} = I_{load}$, any increase in I_{Lf} causes corresponding decrease in I_{in} . This action will continue until I_{in} hits the lower hysteresis band (lower hys. Band =

$I_{ref} \sin \omega t - \Delta h$) resulting in the turn off of S_{AU} and S_{BL} . As soon as I_{in} is less than the reference signal by an amount equal to the hysteresis limit, the control circuit disables the gating signals to S_{AU} and S_{BL} ; and sends signals to turn on S_{BU} and S_{AL} . The inductor current begins to ramp down (because now the voltage across L_f is negative and is equal to $-V_{dc} - V_{ac}(t)$) during this interval resulting in the corresponding increase in the ac input current. This will continue until I_{in} hits the upper hysteresis band (upper hysteresis band = $I_{ref} \sin \omega t + \Delta h$) resulting in the disabling of signals to S_{BU} and S_{AL} and subsequent turn on of S_{AU} and S_{BL} . Thus, the input mains current is forced to stay within an imaginary hysteresis window around the reference signal. Therefore, it is possible to set the magnitude and phase angle of the waveform of the input current at any desired value and at any power factor by changing the magnitude and phase angle of the reference signal with respect to the ac mains voltage. This allows the battery energy storage system to provide reactive power compensation and active filtering besides the traditional load leveling function.

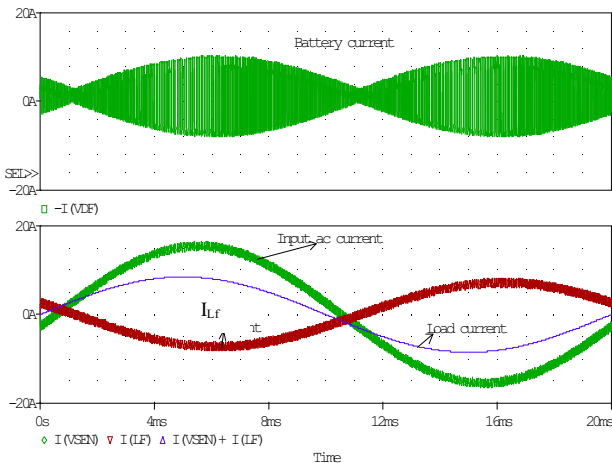

Fig. 5: Simulation Waveform

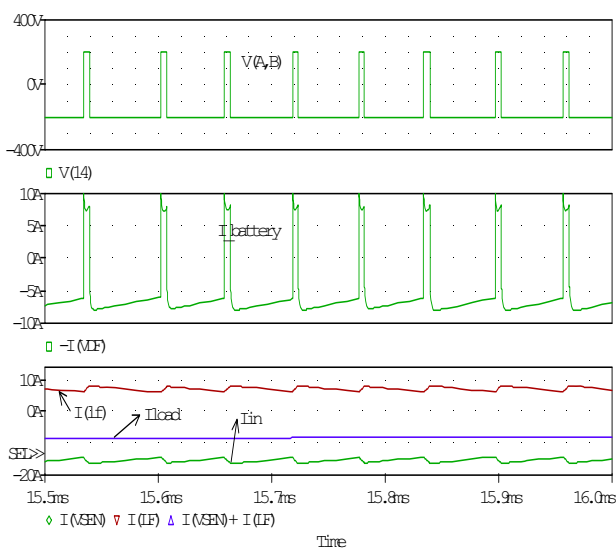

Fig. 6: The waveforms during the time when the inductor current I_{lf} is positive.

Figure 5 shows the waveforms from the simulation of the circuit shown in Figure 4 using PSPICE in one ac mains

frequency. The waveforms of battery current, current from the ac mains, current through L_f and the load current are shown in the figure. Students find it difficult to extract information from the simulation results, which does not help the students to understand what is happening in the circuit at any given instant of time. In order to observe the topological changes within one switching frequency, the time axis is enlarged and the waveforms in Figure 5 are replotted as shown in Figure 6.

Figure 6 shows an expanded view during the time when the current in the inductor (I_{lf}) is positive. As can be observed, the voltage $V(A,B)$ is shifting between positive and negative values in one switching cycle. We can see that when $V(A,B)$ is positive, $I_{battery}$ (dc current) is also positive. Students can now refer back to the flow chart and find out that S_{AU} & S_{BL} have to be in conduction for $V(A,B)$ to be positive and then draw the equivalent circuit as shown in Figure 7. By denoting the direction of various currents in the equivalent circuit, students now will be able to understand clearly the path taken by the current during this switching period.

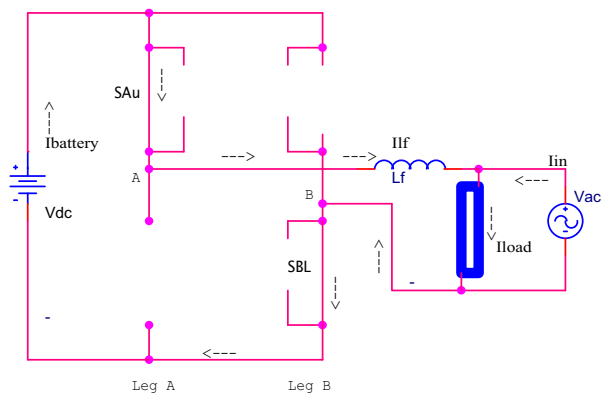

Fig. 7: Equivalent stage when S_{AU} & S_{BL} are in conduction

Figure 7 shows that the positive voltage across the inductor causes I_{lf} to ramp up linearly which in turn causes I_{in} to ramp down until I_{in} hits the lower band of hysteresis. The controller will then disable the gating signals to S_{AU} & S_{BL} and activates the gating signals for S_{BU} & S_{AL} . The above topology ends with the turn off of S_{AU} and S_{BL} .

The next task for the students is to draw the equivalent circuit when $V(A,B)$ is negative. In Figure 6, we see that when $V(A,B)$ is negative, $I_{battery}$ is also negative and as before students may be asked to draw the equivalent circuit as in Figure 8 for this stage with the help of the flow chart. The chart indicates that, during this instant of time D_{AL} & D_{BU} are in conduction much to the surprise of students! This is a very important observation from the view point of students for they would be under the impression that S_{AL} & S_{BU} would conduct when S_{AU} & S_{BL} are turned-off.

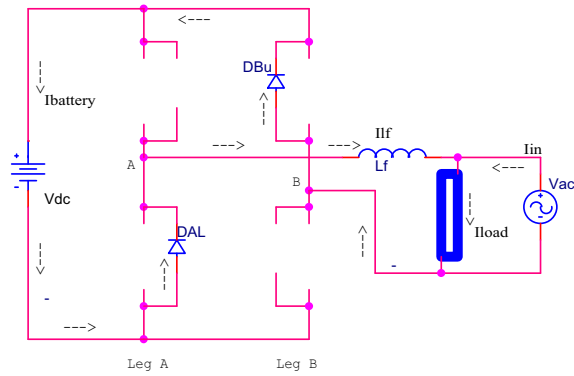

Fig. 8: Equivalent stage when D_{BU} & D_{AL} are in conduction.

The stage in Figure 8 is essential to apply a negative voltage across the inductor and force I_{LF} to ramp down resulting in the corresponding increase in I_{in} . This stage will continue until I_{in} hits the upper hysteresis band forcing the controller to signal the turn on of S_{AU} & S_{BL} . The above stage ends with the turn-off of D_{BU} & D_{AU} and turn-on of S_{AU} & S_{BL} .

Students can be asked to discuss the following among themselves through mutual discussion, which creates an environment for an interactive learning in the class room: why doesn't the current flow through S_{BU} and S_{AL} when even when the gating signals are ON? Why does the current choose to flow through D_{BU} and D_{AL} instead?

Students can be reminded to apply their knowledge of circuit theory to find the answer, which lies in the basic property of an inductor to maintain the direction of its current. The fact that S_{BU} & S_{AL} are uni-directional and that the direction of the current in L_f must remain unchanged by the property of inductance, causes the current in L_f to flow into the battery through D_{BU} & D_{AL} .

Observation: The explanation using the proposed flow chart exposes one hidden aspect of switching states of the devices. Whenever the inductor current is positive only S_{AU} & S_{BL} or D_{BU} & D_{AL} can conduct. This means that S_{BU} & S_{AL} do not carry current instead their anti-parallel diodes carry current during the period whenever the inductor current is positive. This can be verified by observing the simulated waveforms and referring to Table 1. Students can be asked to check the validity of the flow chart by blanking the gating signals for S_{BU} & S_{AL} during the time when the inductor current is positive. By doing so, they will see that the circuit works just the way it does with the gating signals on.

During one half cycle, when the inductor current is positive, there are only two equivalent circuits switching alternately between Figures 7 and 8. Note that, even when S_{BU} and S_{AL} are ON, no current is flowing in them! Because of the direction of I_{LF} , the current only flows in D_{BU} and D_{AL} . And even though $V(A,B)$ is negative, the current in L_f is still positive since the switching period is so short that it cannot reach the negative value. This clearly exposes a fact that during the positive half cycle of the inductor current, one set of switches S_{AL} & S_{BU} does

not conduct in spite of the presence of the gating signals from the control circuit.

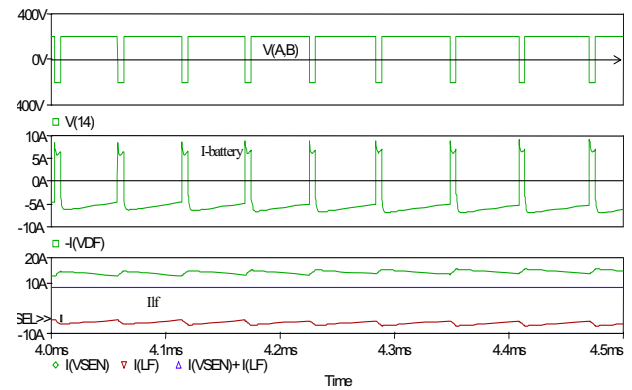

Fig. 9: The waveforms during the period when I_{LF} is negative

Figure 9 shows an expanded view of the waveforms of Figure 5 during the time when the inductor current is negative. By following similar procedure mentioned above, the equivalent circuits for this period are drawn as in Figures 10 (when $V(A,B)$ is negative) & 11 (when $V(A,B)$ is positive).

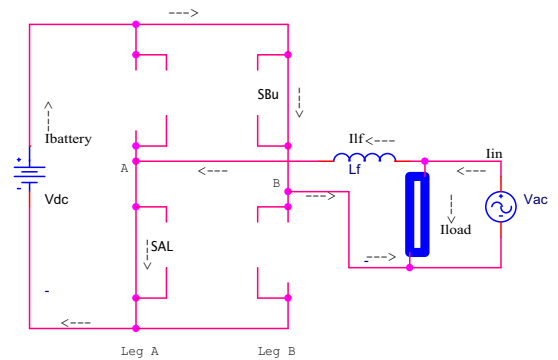

Fig. 10: Equivalent stage when S_{AL} & S_{BU} are in conduction

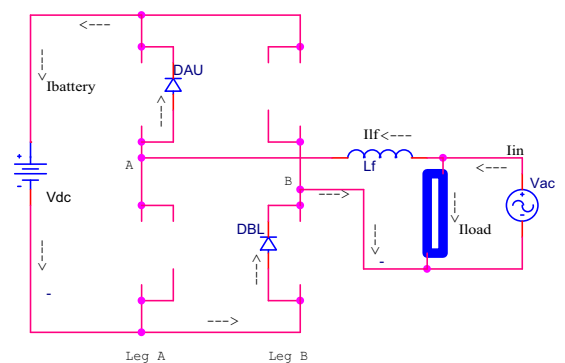

Fig. 11: Equivalent stage when D_{AU} & D_{BL} are in conduction.

The main difference between Figure 6 & Figure 9 is that the waveforms of $V(A,B)$ and $I_{battery}$ exhibit similar polarities in Figure 6 while in Figure 9, they have polarities opposite to each other.

Observation: We can see from Figure 11 that during the period when the inductor current is negative, the active switches S_{AU} & S_{BL} do not conduct even though they are turned ON. This is because the switches are uni-directional

and cannot allow current to flow backward through them (although the gating signals are present).

IV. EXPLANATION OF THE PROCESS DURING THE DISCHARGING AND CHARGING OF THE BATTERY

An example for the use of the flowchart-aided explanation to explain conducting states of both active switches and their parallel diodes in an inverter in a battery energy storage system is presented in the previous section. In order to further test the understanding of students, many questions can be set based on the above discussion. One such example that was included in our tutorial will be given below. Students would notice from the above discussion that a pair of active switches and a pair of diodes switch alternately conducting in each half cycle and thereby draw conclusions about the roles played by the active and passive switches of an inverter circuit; a) Current through two switches is possible only when the dc current is positive; Battery discharges through active switches b) Current through two diodes is possible only when the dc current is negative; Battery is charged only through passive switches. The task set for students is to explain how the battery gets discharged when the active and passive switches are switching alternately? A simulation of the case of discharging of the battery is carried out by setting the load current at 10 A rms, ac mains current at 3 A rms. As the load current is higher than the input ac mains current, the battery will supply the remaining current of 5 A rms as demanded by the load. A plot of the rms current through SAU and DAU is plotted below. It is interesting to note that the rms current carried by the active switch is higher than that by the diode.

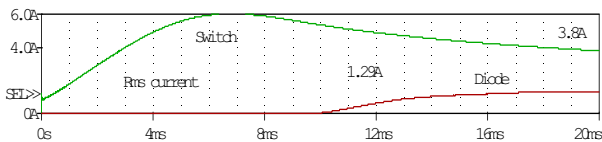

Fig. 11: rms current through an active and passive switch during discharging mode.

This will motivate students to think and try to reason why the rms current through an active switch should be more during the discharging mode. This will test the ability of students to apply the knowledge into solving a problem. Since the input ac mains current is smaller than the current demanded by the load, the load draws current from the battery through the inverter. As it is known that the only active switches can carry current from the battery to the load and that there is a net discharge from the battery, it is natural that the rms current through an active switch is more (since rms current is proportional to the conduction time) than the rms diode current. This can be extended further to say that during discharging mode, the active switches conduct for a longer time than when the diodes conduct resulting in the net discharge from the battery in one ac mains cycle. Similarly a case of charging mode can be carried out by setting the load current less than the ac mains current so as to allow excess current from the mains to charge the battery. In this case, students will notice that

the rms current through a passive switch (diode) is more than that through an active switch for obvious reasons. The fact that the input ac current is higher than the load current, forces the battery to be charged. This can be extended by saying that during the charging mode, on average the conduction time of passive switches (diodes) is longer than the conduction time of the active switches. In essence, the controller automatically reduces the conduction time of the active switches permitting more current to flow through the passive diodes resulting in the net charging of the battery.

V. CONCLUSIONS

In order to aid students to understand the switching states of the devices in an inverter circuit used for power system applications, a simple yet general flow chart is developed. The use of such a chart in understanding the operation of a battery energy storage system is also discussed. By following the flow chart, students can determine the switching states of the devices of a single-phase inverter using any type of control. The chart is developed mainly to encourage students to learn and apply a concept in a systematic manner. The chart helps students to interpret the results from PSPICE simulation to draw the equivalent stages at any given instant of time. The tutorial is very helpful in guiding students to interpret the results from PSPICE simulations and motivating them to apply theory to solve problems. An interactive computer based tutorial is being developed and will be included in the undergraduate course of Power Electronics in near future.

ACKNOWLEDGMENTS

The authors gratefully acknowledge the support of VTU, Belgaum, Management of REVA ITM, Bangalore and The Hong Kong Polytechnic University to the project.

REFERENCES

- [1] N Mohan, T.M. Undeland, W.P. Robbins, "Power Electronics converters, applications and design," John Wiley & Sons.
- [2] Lachs, W.R. and D. Sutanto, "Battery storage plant within large load centers," IEEE Transactions on Power Systems, vol. 7, No.2, May 1992, pp.762-769.
- [3] D.M. Divan, "Resonant DC link Converter – A new concept in static power conversion," IEEE-IAS conference proceedings 1986, pp. 267-280
- [4] R.W. De Doncker, J.P. Lyons, "The Auxiliary quasi-resonant DC link inverter," PESC 91, pp. 248-253.