



UNIVERSITY
OF WOLLONGONG
AUSTRALIA

University of Wollongong
Research Online

Faculty of Informatics - Papers (Archive)

Faculty of Engineering and Information Sciences

2010

Monitoring intelligent distribution power systems: a power quality plan

Neil R. Browne

Integral Energy

Timothy J. Browne

PSC, tbrowne@uow.edu.au

Sean T. Elphick

University of Wollongong, elpho@uow.edu.au

Publication Details

N. Browne, T. J. Browne & S. T. Elphick, "Monitoring intelligent distribution power systems: a power quality plan," in 14th International Conference on Harmonics and Quality of Power ICHQP 2010, 2010, pp. 1-7.

Research Online is the open access institutional repository for the University of Wollongong. For further information contact the UOW Library:
research-pubs@uow.edu.au

Monitoring intelligent distribution power systems: a power quality plan

Abstract

Power system monitoring capabilities and requirements are evolving rapidly. The traditional monitoring framework in Australian distribution networks involves biannual readings of maximum demand at each distribution substation. As utilities respond to developments in metering and communications technology, automated collection and retrieval of quasi-real-time system data between substations and central repositories is now feasible. This gives network managers a significantly increased understanding of distribution network dynamic activity such as daily and seasonal load profiles. This leads to the increased ability of utilities to exploit metering data for power quality analysis purposes. This paper examines the scope for, and challenges associated with, integration of power quality monitoring with advanced metering. Emphasis is directed towards technical and regulatory conditions applying to Australian distribution utilities. Particular consideration is given to the different characteristics of the various types of sites where monitoring is required.

Keywords

Monitoring, intelligent, distribution, power, systems, power, quality, plan

Disciplines

Physical Sciences and Mathematics

Publication Details

N. Browne, T. J. Browne & S. T. Elphick, "Monitoring intelligent distribution power systems: a power quality plan," in 14th International Conference on Harmonics and Quality of Power ICHQP 2010, 2010, pp. 1-7.

Monitoring Intelligent Distribution Power Systems – a Power Quality Plan

Neil R. Browne *Member, IEEE*, Timothy J. Browne, *Member, IEEE* and Sean Elphick

Abstract—Power system monitoring capabilities and requirements are evolving rapidly. The traditional monitoring framework in Australian distribution networks involves biannual readings of maximum demand at each distribution substation. As utilities respond to developments in metering and communications technology, automated collection and retrieval of quasi-real-time system data between substations and central repositories is now feasible. This gives network managers a significantly increased understanding of distribution network dynamic activity such as daily and seasonal load profiles. This leads to the increased ability of utilities to exploit metering data for power quality analysis purposes. This paper examines the scope for, and challenges associated with, integration of power quality monitoring with advanced metering. Emphasis is directed towards technical and regulatory conditions applying to Australian distribution utilities. Particular consideration is given to the different characteristics of the various types of sites where monitoring is required.

I. DEVELOPMENT AND CURRENT STATE OF DISTRIBUTION SYSTEM MONITORING

DECISION making in distribution businesses relies heavily on network data. The methods of collecting, storing and processing this data are changing rapidly.

In the past, large substations were staffed during office hours and in some cases continuously. Elsewhere, distribution monitoring was achieved through periodic site visits by technical staff. For example, maximum demand indicators are commonly installed in distribution substations, and read biannually to provide summer and winter loading levels. This data is used for planning and asset condition monitoring purposes. Similarly, meter readers have traditionally visited every customer meter once each billing period to collect revenue data. Any power quality or asset condition monitoring has been performed on an individual case-by-case basis with application-specific instrumentation. It was usually installed for a survey period (typically one week).

For the modern electricity distributor, Supervisory Control And Data Acquisition (SCADA) systems have largely replaced the need for staff to frequent or occupy substations in order to collect data. So-called ‘smart meters’, able to report revenue data directly to a utility central repository, are replacing the role of the human meter reader. Modern metering includes the ability to record and transmit to the utility power quality and asset condition data, in addition to the traditional revenue data. Fast data retrieval is possible, making it accessible even for system operational purposes.

Author N. R. Browne is with Integral Energy and can be reached at neil.browne@integral.com.au. Author T. J. Browne is with PSC and can be reached at tbrowne@ieee.org. Author S. Elphick is with the University of Wollongong and can be reached at elpho@uow.edu.au

As these changes become more widespread, distribution utilities face new opportunities to gain increased understanding of network conditions. One such opportunity is the potential ability to improve coordination of power quality (PQ) disturbance emissions with equipment immunity levels. However, these opportunities are tempered by challenges posed by the collection, transport, storage and dissemination of substantially more data than was the case when data collection was largely a manual function.

II. COMMUNICATION SYSTEMS

Early communication systems were developed to support SCADA systems. At the distribution level they often relied on utility owned or leased copper pilots, with some microwave or power line carrier for trunk routes, associated with high voltage lines. Bandwidth was often limited, so only essential operational data was transmitted. Only recently in Australia has optical fibre been deployed on distribution networks. At the time of writing there are still many zone substations which do not have fibre connections.

There is now a recognised need to communicate with interval meters located at customer connection points. A number of technologies are available, including wireless and power line carrier over low voltage lines. These are being used to provide the “last mile” link from a data concentrator to a group of meters. The data concentrator typically has an optic fibre link to the central data server.

III. POTENTIAL TYPES OF MONITORS

Revenue meters and PQ monitors can both be used for network monitoring.

A. Revenue Meters

Interval metering is shortly to be rolled out throughout Australian distribution businesses [1]. These monitoring devices may provide an opportunity for continuous monitoring of the PQ at every point of supply to customers. They also open up opportunities for remote control of load, and can provide the customer with price and consumption data. Armed with this data the customer can make informed decisions on managing load.

Distribution businesses supply residential, commercial and industrial loads. These loads include motors, resistive heaters, induction heaters, switched-mode power supplies for computers, multimedia devices and lighting. There is a growing trend for generation to be integrated or embedded within a customer

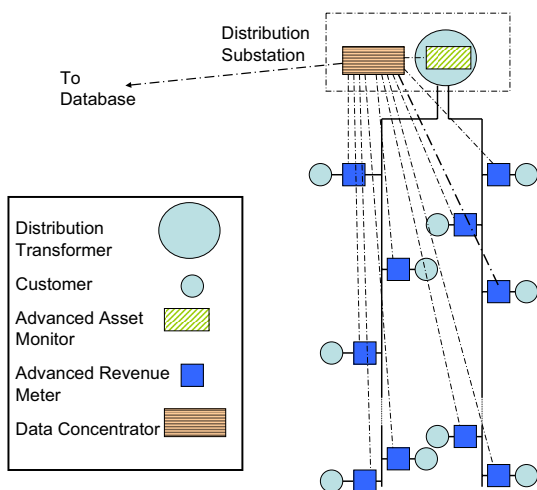

Fig. 1. Typical Low Voltage Distribution System Monitoring

installation. The generation technology is wide ranging and can affect PQ, either adding to or absorbing disturbances.

Equipment which is sensitive to PQ disturbances is increasingly being connected in juxtaposition with distorting loads and sources which create PQ disturbances.

A better understanding of emission and immunity levels at the customer premises is needed in order to manage PQ issues effectively. Using revenue meters to monitor PQ provides the data to achieve this understanding. A typical distribution substation and low voltage customer supply arrangement is shown in Fig. 1. A revenue meter which can also monitor asset condition is a desirable feature to include at the distribution substation and is shown here as an advanced asset monitor.

Revenue meters are available now which provide steady state voltage, unbalance, total harmonic distortion and sag event information in addition to their revenue function.

B. PQ Monitors

Utilities are increasingly obliged to ensure compliance with regulatory requirements by continuous monitoring of PQ. At substations supplying large numbers of customers, the power quality has an impact on all of them. Consequently collection of detailed and accurate data at these points is valuable to the distribution business. Statistical energy metering is provided to collect data on the power and energy supplied. While some statistical meters can provide limited PQ data (for example volts, sag depth, sag duration), PQ monitors provide more detailed information. PQ monitor information is in accordance with PQ testing and measuring standards such as IEC 61000-4-30 [2]. Zone substation sites such as these supply tens of MVA of load comprising domestic, commercial and industrial customers. A typical zone substation arrangement is shown in Fig. 2.

IV. POTENTIAL APPLICATION OF MONITORS

Information from monitors has a wide range of applications to various parts of the distribution business.

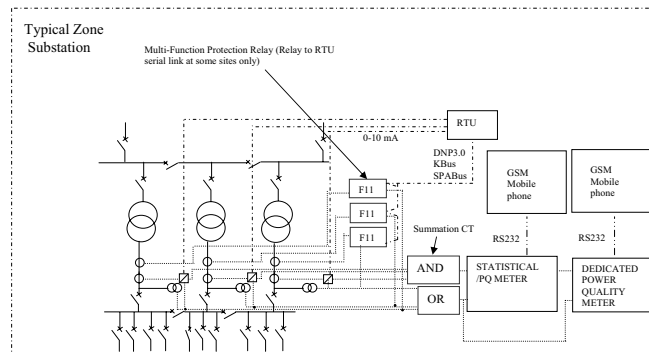

Fig. 2. Typical Zone Substation Monitoring

A. Energy and Peak Demand Management

Interval metering, in conjunction with two-way communication systems back to a central control centre, can be used for switching loads or to provide pricing signals to assist customers in making choices on energy use. Benefits are apparent in the management of both energy and peak demand.

Energy management is of commercial interest to the distribution business, particularly when incentives exist to reduce consumption. Such incentives could be in the form of regulatory limits or pricing. In either case, interval metering offers the utility the ability to pass the incentive on to the customer in quasi-real-time.

Peak demand management is essential for effective utilisation of network resources. It is a key element in the network planning process. At times of high demand and high price, communication of a real-time pricing signal to a customer via an interval meter offers encouragement to curtail demand.

B. Fault Recording

PQ monitors can provide valuable data for fault analysis following system events. Often the PQ data complements the fault recordings which are downloaded from modern protection relays.

Both PQ monitors and protection relays have the drawback of limited inputs. Each device generally only measures one set of three-phase currents and voltages. In substations where there are ten or more outgoing feeders and two to three power transformers, it is not always cost effective to monitor all circuits with conventional PQ instruments.

C. Asset Management

Distribution substation monitoring provides valuable information about the condition of assets. Cycling loading of transformers affects their useful life, so knowledge of loading history facilitates decision making on asset replacement. The ratings of fuses inside padmount or kiosk distribution substations are significantly affected by temperature. The temperature within a distribution substation depends not only on ambient conditions such as solar radiation, ambient temperature, wind, but also on transformer loading and substation ventilation. A temperature monitoring system provides valuable information which can be used to ensure the correct fuses are applied. It

is also useful in determining transformer rating as accurately as possible.

D. Network Operation and Reliability Benefits

Interval meters can be used to signal to system control staff when there has been a loss of supply. Careful specification and design of meters ensures they retain “last gasp” information when the power supply fails. The meter can then inform operators of where and when interruptions to supply have occurred, as well as the causes of interruptions. Rapid identification of loss of supply and the exact location has the potential to result in significant improvements in network reliability.

E. Generation

Distribution businesses are faced with a plethora of generation types being connected to their networks. They range from domestic inverter installations for solar panels of a few kW to standby commercial diesel induction generators of several hundred kW to synchronous generators of hundreds of MW. Fuel types being considered include solar, fuel cells, hot fractured rock (geothermal), tidal, wave power, wind, biomass, diesel, and gas. They may be embedded deep within a customer installation or directly connected to the distribution network.

Interval metering at the generator connection point provides detailed information, including PQ, on generation which is connected to the distribution network. This information can assist the distribution utility in network operation, network performance assessment and network development planning.

V. RECONCILIATION BETWEEN PQ DISTURBANCE EMISSION AND IMMUNITY

The PQ of a power system depends on generation, network configuration, and load characteristics. Customer loads both influence and are affected by PQ. The level of impact varies not only according to the type of disturbance but also according to the degree with which customer equipment can tolerate the disturbance. This is usually referred to as immunity. Customer loads also affect PQ, for example by producing harmonic currents. The disturbances created by customer loads and other sources which affect PQ are generally referred to as emissions. Regulators typically impose limits on emissions. Distribution businesses and customers are required to manage emissions within regulated limits. Continuous monitoring provides data to indicate if limits are exceeded, if parameters are close to limits and if there are any trends which need attention to prevent future breaches of limits.

The level of immunity of customer equipment to PQ disturbances is not widely understood by equipment owners. Equipment failures are not necessarily correlated with power system disturbances to check if immunity levels are adequate. It is only when the cause of process interruption and equipment failure is investigated that this issue comes under scrutiny.

The IEC 61000 family of standards provides guidance to utilities and customers to assist in ensuring adequate margins between emission and immunity levels. Continuous PQ monitoring offers distribution utilities and customers the ability to

reconcile disturbance emissions with immunity levels. Mismatches between the two can then be identified and corrected.

A. Voltage Sags

The impact of voltage sags has been recognised by both European and Electric Power Research Institute (EPRI) studies as a significant cost to the community [3].

Apart from ITIC [4] and SEMI F47-0706 [5], both of which relate to specific industries, there is very little in the way of standard requirements in equipment specifications for sag immunity. Sag emission levels are largely a function of protection settings, network impedances and fault characteristics. Improvements in emissions often require great expense involving such projects as network reconfiguration, underground conversion or communications networks for high speed protection.

B. Waveform Distortion

Equipment immunity to waveform distortion is addressed by standards such as IEC 61000-3-2 [6], IEC 61000-3-4 [7] and IEC 61000-3-12 [8]. Emission limits are given in IEC 61000-3-6 [9] as planning and compatibility levels. The evolution of these standards in the 1980s and 1990s was based on European observations of an upward trend in 5th harmonic levels associated with television viewing habits [10]. However subsequent case studies have shown no evidence of such a trend in Australia [11]. Nevertheless, continuous monitoring facilitated these case studies and is a valuable tool in ensuring any trends in harmonic levels are detected at an early stage. Losses due to harmonics and the reduction in equipment life are a cost to the community. Waveform distortion can easily go unnoticed by the customer, so systematic monitoring and reporting is a valuable tool for distribution utilities.

C. Voltage Fluctuation and Flicker

Equipment immunity to voltage fluctuations is addressed by standards such as IEC 61000-3-3 [12] and 61000-3-5 [13]. Emission limits are given in IEC 61000-3-7 [14] as planning levels. Flicker is a human reaction to a constantly varying light source. Fluorescent lamps have flicker performance which is completely different from that of incandescent lamps [15]. Recent years have seen the traditional incandescent lamp replaced by energy saving types; predominately compact fluorescent lamps (CFLs). Consequently, flicker emission standards are now under review and emphasis is being placed on the impact of flicker on equipment as opposed to the human reaction.

D. Variations in Steady State Voltage

IEC standard 60038 [16] sets nominal levels for steady state voltage. However it does not prescribe how voltage is to be measured or how frequently excursions are permitted. There is currently no PQ standard which details measurement and analysis techniques for steady state voltage. Such a standard would be useful for product specification and network planning. It could provide a basis for appropriate PQ monitor design and configuration.

E. Voltage Transients

Basic insulation levels are given for specific plant and equipment but do not relate directly to oscillatory or impulsive transients. Voltage transient emission and immunity levels are not prescribed in international standards as yet. Until these are developed, measurement and assessment of voltage transients are dependent on design decisions made in the development of specific instrumentation. However, collection of event data is useful for statistical reference in any future standard development and for fault analysis. Transient measurement data can also assist in detection of amplification of capacitor switching transients and in optimising capacitor location.

F. Voltage Unbalance

Overhead line configuration, transformer and capacitor switching and single phase load connection practices all contribute to emission levels. Voltage unbalance emission limits are prescribed in the new IEC standard 61000-3-13 [17]. Immunity levels for unbalance vary greatly for different types of equipment. Induction motors are particularly susceptible to unbalance. Unbalance can also affect transformer losses and overload harmonic filters and capacitor banks.

VI. MONITOR SPECIFICATIONS

Monitor specifications can be broadly divided into three different groups.

The first is the revenue meters purchased for customer connections. These are basic devices generally designed for power usage metering and collection of fundamental voltage and current data. Some of these have additional PQ capability. These devices are much cheaper than more sophisticated dedicated PQ monitors. They are generally highly accurate at measuring fundamental voltage and current values as well as voltage sags. Performance for other PQ parameters is often inferior to that of more sophisticated (and expensive) monitors.

The second group is PQ/asset monitors for distribution substations. These supply 10, 15 or 30 minute data on substation loading, which is critical for load forecasting. They are also a valuable asset management tool. Maximum Demand Indicators have traditionally been provided on most distribution transformers. They are being replaced with advanced revenue meters with some PQ functionality.

The third group are the dedicated PQ monitors. These are highly accurate devices which measure the whole gamut of PQ disturbances and generally comply with PQ monitoring standards such as IEC61000-4-30. Future multi-feeder zone substations could incorporate combined PQ monitors and fault recorders. The use of multi-input devices monitoring several three-phase voltage and current inputs is envisaged.

VII. LOCATION OF MONITORS

Network infrastructure costs range from tens of millions of dollars for substations at the subtransmission level down to thousands of dollars or less at the domestic customer level. In contrast, the number of sites at domestic customer level is several orders of magnitude greater than the number of subtransmission sites. The cost of domestic monitoring equipment

is therefore significant by virtue of the number of sites. A comparison of relative costs is given in Table I. Developments in revenue meters and associated communications systems will see a massive expansion in the availability of PQ data at the low voltage level. This will facilitate monitoring at the connection point with customers.

If a comprehensive understanding of the network performance is to be accomplished, a monitor location strategy must be developed such that statistical confidence is ensured, network planning operations can be achieved and that any perceived problem sites are included. The monitor location strategy must also be designed to take into account all of the possible network and site/load characteristics. Network characteristics include voltage levels, network constructions (e.g. overhead underground), feeder lengths and climatic/geographical factors. Site characteristics include the load type and location.

Some practicalities must also be considered when selecting monitor location. These include the availability of suitable transducers at medium voltage (MV) and high voltage (HV) sites as well as weatherproofing for instruments which are installed outdoors.

As detailed in Section VI, there are various monitor technologies available with their associated advantages, disadvantages and costs. Any extensive monitoring system must weigh the costs of the monitor technology against the benefits to be obtained. For instance, little benefit would be obtained from installing costly advanced PQ monitoring instrumentation at every domestic customer. This is due to the fact that voltage levels from one customer to the next will be almost identical. Further, emission levels from single domestic customers will not have a large impact on network performance. However, there is a strong case for advanced instrumentation at sites such as zone substations, as monitoring at these sites will give an indication of PQ levels at a large number of customer sites. Advanced monitoring must also be placed at large customer sites where emission levels are high or PQ contractual obligations are in place.

As previously described, permanent monitors serve multiple functions in addition to PQ monitoring. The choice of location is a compromise based on the relative value of these functions.

A. Monitoring at Low Voltage Sites

The connection point is an appropriate starting place to investigate immunity problems, since most immunity problems are at low voltage (LV), where most of the distribution customers are connected.

Waveform distortion is partly an LV phenomenon (but exacerbated by MV system devices such as capacitor banks) and partly attributable to large industrial loads at MV. Monitoring close to the LV sources of distortion offers early detection of changes which may result from widespread introduction of new technology such as compact fluorescent lights or domestic grid-connected solar panel inverters. Voltage unbalance is largely from LV load — refer Voltage Unbalance Case Study [18]. Variations in steady state voltage levels result from load changes and are of particular concern in rural and semi-rural areas where LV feeders are long.

Given the above, there is a strong case for installation of monitors capable of measuring a range of PQ disturbances including harmonics and unbalance at the distribution substation and at the ends of LV feeder runs. These would likely be the monitors listed as the second group in Section VI. Little additional data will be obtained from PQ meters installed in every domestic residence and as such, basic revenues meters which would provide fundamental voltage and current values would be appropriate for the majority of domestic customers.

B. Monitoring at Medium and High Voltage Sites

Most sag emissions are at the MV level, due to the large aggregated feeder lengths. Large industrial loads at MV also can generate significant harmonic emissions. Monitoring at MV and HV is useful to check on large specific loads and capacitor bank effects on waveform distortion.

As stated above, there is a strong case for dedicated power quality monitors at all MV and HV substations. Similar monitoring devices would also be installed at large customers.

VIII. REGULATORY COMPLIANCE FOR PQ

In Australia, network reliability has been the main focus for regulators and power quality has generally been a second-order consideration. However, the recent past has seen regulators take a much stronger interest in PQ compliance. This includes distribution companies being obliged to comply with PQ limits [19]. Some jurisdictions also require distribution businesses to install monitoring devices at specified locations on their networks. With both customers and regulators becoming more aware of the impact of PQ it is likely that regulatory obligations will increase in the future.

IX. DESIGN OF MONITORING SYSTEM

A possible monitoring scheme for future networks is shown in Fig. 3. The dataflow for such a system is shown in Fig. 4. Metering and other data is collected from various sources and stored in the utility's Network Load History database. This includes metered electrical quantities from zone and transmission substations, as well as from pole mounted reclosers. Such quantities as bus voltages, feeder and transformer currents, transformer real, reactive and apparent power, tap changer positions are stored.

X. DATA MANAGEMENT ISSUES

In existing installations, around 8.8 MB of PQ data per revenue meter per year is collected. PQ monitors provide around 108 MB each per year. If there was a revenue meter at every distribution transformer, then 26,000 times 8.8 MB, or 230 GB of data per year would be collected. If a PQ monitor was installed at each zone and transmission substation they would supply 170 times 108 MB, or around 18 GB of data per year.

With such large quantities of data being collected, systems for monitoring data quality are necessary. Data quality can be affected by such things as instrument transformer errors, secondary wiring issues, faulty monitors, communication failures and database corruption.

TABLE I
RELATIVE COSTS OF SITES

Site Voltage Level	Site Description	Capital Cost of Site AUD x 1,000	Cost of Meter AUD x 1,000	No of Sites	Accuracy
HV	180–360MVA Transmission Substation	80,000	10	20	AS/NZS 61000.4.30 Class A
MV	90 MVA Zone Substation	40,000	10	150	AS/NZS 61000.4.30 Class A
LV	0.15–1 MVA Distribution Substation	50	1	26 × 10 ³	0.2 Revenue metering
LV	Customer	1	1	850 × 10 ³	0.2 Revenue metering

XI. REPORTING

As stated above PQ monitoring will produce copious amounts of data. The challenge with reporting PQ data is to reduce this large volume of data down to a form which is understandable without losing important detail. To achieve these ends reporting indices are generally used. For continuous disturbances these are based on statistical methods of evaluation and report PQ disturbances with respect to well defined limits. These indices are generally 95th percentile values and give no information concerning the worst 5 per cent of readings. These indices are well developed and included in standards such as IEC61000–3–6 and EN50160 [20]. For Discrete disturbances, reporting techniques are significantly less developed. Sags may be reported based on depths and durations or plotted against the well known SEMI F47 or ITIC curves. At present there are no well defined reporting techniques for swells or transients.

Even given the reporting techniques detailed above, with the enormous number of sites likely to be monitored in the future, reporting and analysis of the data presents an ongoing challenge to the industry.

XII. CONCLUSIONS

In the future PQ data is likely to be collected by multi-function devices which also meter energy, monitor asset condition and provide operational status information. The choice of device and device location are critical decisions for the distribution business. Improved communications will provide faster updates of meter data accessible to users. Data management techniques will need to be developed to handle the increased amount of data from a large number of sites over a long period of time. In particular, there is a need for archiving and reporting techniques appropriate to the systems being used.

Maximum demand indicators (MDIs) located in distribution substations are gradually being replaced by “smart meters”. Instead of two readings per year giving the maximum load current over each six month period, the meters provide half hourly measurements of voltage, current and power factor. They also record PQ information — harmonics, unbalance and

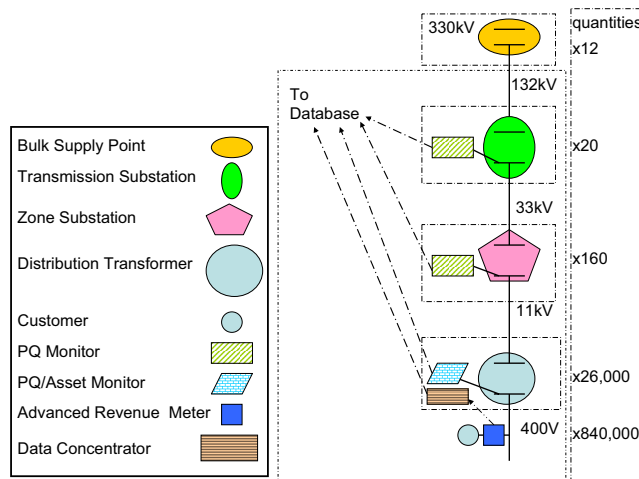

Fig. 3. Monitoring scheme for Distribution Network

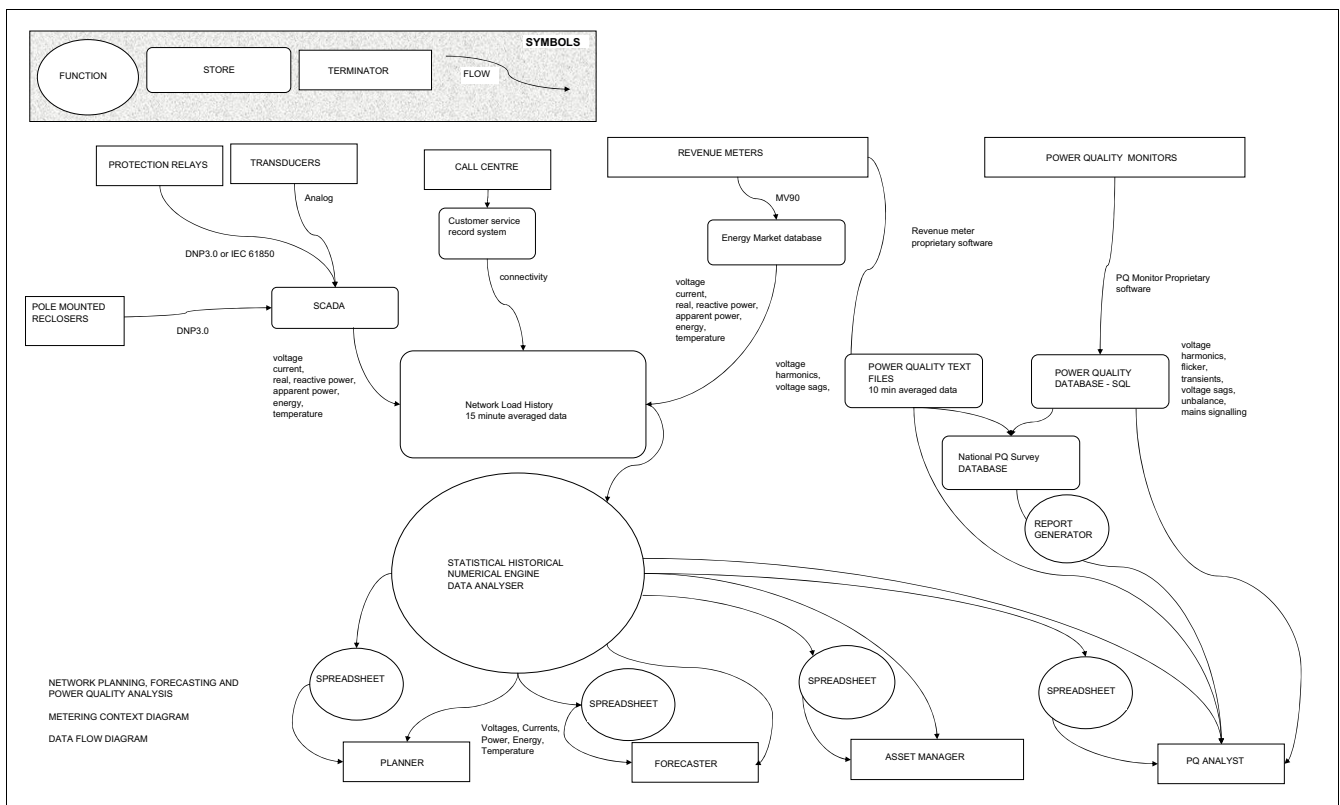

Fig. 4. Metering Data Flow Diagram of Future System

voltage sags. Temperature can also be recorded. The recorded information is stored in a central database automatically, available for access by relevant stakeholders.

This increased level of detailed information gives the potential of much greater understanding of PQ, asset conditions and network performance. PQ emission levels, fuse deterioration, transformer ageing and network losses will be better understood using this information. Load control and energy management by residential and commercial meters will become a standard feature. This will allow optimisation of

asset usage for the benefit of both customers and distributors.

The implementation of advanced metering involves a significant data management issue. Collection, compression of information into meaningful forms, archiving, and retrieval are all areas where the large volume of data can be expected to stress distribution utility resources.

Getting the monitoring system right will ensure the appropriate information is available to the people who need it, in a timely manner.

ACKNOWLEDGMENT

The authors would like to thank Integral Energy, PSC and the Integral Energy Power Quality and Reliability Centre at University of Wollongong for their support in this work.

REFERENCES

- [1] (2010, Apr.) National Smart Metering Program. [Online]. Available: <http://share.aemo.com.au/smartmetering/default.aspx>
- [2] *Electromagnetic compatibility (EMC)— Part 4–30: Testing and measurement techniques — Power quality measurement methods*, International Electrotechnical Commission IEC Standard IEC 61 000–4–30:2003–02.
- [3] “PQ in continuous manufacturing,” Leonardo Power Quality Initiative, 2006. [Online]. Available: <http://www.lpqi.org>
- [4] *ITI-CBEMA Curve* —, Information Technology Industry Council International Standard ITIC–2000.
- [5] *SEMI F47 0706 curve* —, Electric Power Research Institute International Standard SEMI F47–0706–2006.
- [6] *Electromagnetic compatibility (EMC)— Part 3–2: Limits — Limits for harmonic current emissions (equipment input current less than or equal to 16 A per phase)*, International Electrotechnical Commission IEC Standard IEC 61 000–3–2:2005.
- [7] *Electromagnetic compatibility (EMC)— Part 3–4: Limits — Limitations of emissions of harmonic currents in low-voltage power supply systems for equipment with rated current greater than 75 A*, International Electrotechnical Commission IEC Standard IEC 61 000–3–4:1998.
- [8] *Electromagnetic compatibility (EMC)— Part 3–12: Limits — Limitations for harmonic currents produced by equipment connected to public low-voltage systems with input current greater than 16 A and less than or equal to 75 A per phase*, International Electrotechnical Commission IEC Standard IEC 61 000–3–4:1998.
- [9] *Electromagnetic compatibility (EMC)— Part 3–6: Limits — Assessment of emission limits for the connection of distorting installations to MV HV and EHV power systems*, International Electrotechnical Commission IEC Standard IEC 61 000–3–6:2008.
- [10] *Electromagnetic compatibility (EMC)— Part 1–4: General — Historical Rationale for the limitation of power-frequency conducted harmonic current emissions from equipment, in the frequency range up to 2 kHz*, International Electrotechnical Commission IEC Standard IEC 61 000–1–4:2005.
- [11] N. Browne, S. Perera, and P. Ribeiro, “Harmonic levels and television events,” in *2007 IEEE Power Engineering Society General Meeting, Tampa, Florida, Tampa, United States of America, Jul. 2007*.
- [12] *Electromagnetic compatibility (EMC)— Part 3–3: Limits — Limitation of voltage changes, voltage fluctuations and flicker in public low-voltage supply systems for equipment with rated current less than or equal to 16 A per phase and not subject to conditional connection*, International Electrotechnical Commission IEC Standard IEC 61 000–3–3:2002.
- [13] *Electromagnetic compatibility (EMC)— Part 3–5: Limits — Limitation of voltage changes, voltage fluctuations and flicker in public low-voltage supply systems for equipment with rated current greater than 75 A*, International Electrotechnical Commission IEC Standard IEC 61 000–3–5:2009.
- [14] *Electromagnetic compatibility (EMC)— Part 3–7: Limits — Assessment of emission limits for the connection of fluctuating installations to MV HV and EHV power systems*, International Electrotechnical Commission IEC Standard IEC 61 000–3–7:2008.
- [15] R. Cai, J. Cobbin, J. Myrzik, J. Blom, and W. Kling, “Flicker responses of different lamp types,” vol. 3, no. 9, pp. 816–824, Sep. 2009, ISSN 1751-8687.
- [16] *IEC Standard Voltages*, International Electrotechnical Commission IEC Standard IEC 60 038:2009.
- [17] *Electromagnetic compatibility (EMC)— Part 3–13: Limits — Assessment of emission limits for the connection of unbalanced installations to MV, HV and EHV power systems*, International Electrotechnical Commission IEC Standard IEC 61 000–3–13:2008.
- [18] N. Browne, D. Spoor, and J. Byrnes, “Voltage unbalance in an urban distribution network - a case study,” in *ICHQP 2008 Conference, Wollongong, Australia, Sep. 2008*.
- [19] *National Electricity Rules*, Australian Energy Market Commission Std., 25 Mar. 2010, version 35. [Online]. Available: <http://www.aemc.gov.au/Electricity/National-Electricity-Rules/Current-Rules.html>

- [20] *Voltage Characteristics in Public Distribution Systems*, European Committee for Electrotechnical Standardization European Standard EN50 160:2007.

BIOGRAPHIES



Neil Browne (M'1988): Neil Browne is an engineer with Integral Energy's Strategic Asset Management Branch. He received his Bachelor of Engineering Degree from the University of New South Wales in 1976. He is involved in protection, policy, operational analysis and power quality control and monitoring. Mr. Browne is a Chartered Professional Engineer in Australia.



Timothy Browne (StM '02, M '07): Timothy Browne received the B.E. degree in electrical engineering from the University of New South Wales, Australia, and has completed the Ph.D. degree with the University of Wollongong in 2008. After Post Doctorate studies with Arizona State University, he is now with PSC.



Sean Elphick : Mr. Sean Elphick (Research Associate) graduated from the University of Wollongong with a BE (Elec) degree in 2002. He commenced employment with the Integral Energy Power Quality Centre in 2003. Initially employed to work on a Strategic Partnerships with Industry — Research and Training Scheme (SPIRT) project dealing with power quality monitoring and reporting techniques. His current activities include delivery of the Long Term National Power Quality Survey, a first of its type in Australia as well as various other power quality related research and consulting projects.