



UNIVERSITY  
OF WOLLONGONG  
AUSTRALIA

University of Wollongong  
Research Online

---

Faculty of Engineering - Papers (Archive)

Faculty of Engineering and Information Sciences

---

2010

# Investigation of Measuring Wall Friction on a Large Scale Wall Friction Tester and the Jenike Direct Shear Tester

Andrew Grima

*University of Wollongong*, agrima@uow.edu.au

Brendan P. Mills

*University of Wollongong*

Peter W. Wypych

*University of Wollongong*, peter\_wypych@uow.edu.au

<http://ro.uow.edu.au/engpapers/2671>

---

## Publication Details

Grima, A. P., Mills, B. P. Wypych, P. W. (2010). Investigation of Measuring Wall Friction on a Large Scale Wall Friction Tester and the Jenike Direct Shear Tester. 3rd International conference exhibition BulkSolids Europe 2010 (pp. 1-14). Wuerzburg, Germany: Gerd Kielburger.

Research Online is the open access institutional repository for the University of Wollongong. For further information contact the UOW Library:  
research-pubs@uow.edu.au

# Investigation of Measuring Wall Friction on a Large Scale Wall Friction Tester and the Jenike Direct Shear Tester

**A.P. Grima, B. P. Mills and P.W. Wypych**

Centre for Bulk Solids and Particulate Technologies, Faculty of Engineering  
University of Wollongong, Northfields Avenue, Wollongong, 2522, New South Wales, Australia  
E-mail address: a.p.grima@gmail.com

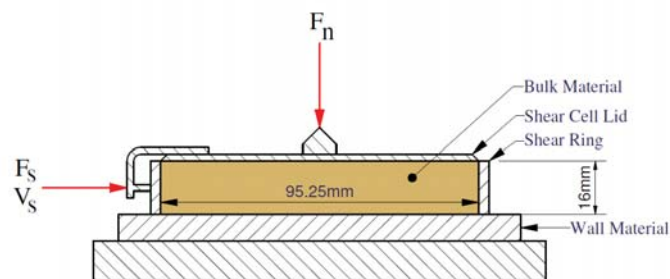
## Abstract

The interaction of a granular material with boundary materials is one of the most important factors to consider when designing mass flow hoppers, chutes, feeders and other equipment where flow is expected to occur. Numerous properties of a bulk material and wall surface influence the measurement of wall friction angles (e.g. particle size and distribution, particle shape, particle and boundary asperities and moisture content) which can be difficult to thoroughly investigate on a standard Jenike direct shear tester. Often the Jenike direct shear tester is limited to small particle sizes, wall sample materials, shear rates and displacements.

This paper presents the design and commissioning of a new large scale wall friction tester (LSWFT) to measure the wall friction angles of dry and wet bulk materials with a wide particle size distribution using a large shear cell. Factors which are examined on the LSWFT include particle size, moisture content, wall sample material conditions (i.e. effects of joints and edges between tiled materials) and shear cell size to improve the understanding of granular material interaction with boundaries to enhance infrastructure performance. The wall yield loci and kinematic angles of wall friction measured from the LSWFT are compared to the Jenike direct shear tester to examine the difference between the two measuring techniques and evaluate the performance of the LSWFT. The results presented in this paper are preliminary and are not intended to show any particle or shear cell scaling effects but to rather demonstrate the potential usefulness of the LSWFT and limitations of the Jenike tester.

## 1 INTRODUCTION

Given the irregular nature of bulk materials, flow property testing is essential for the reliable flow and storage of bulk materials. The sensitivity and variation of boundary or wall friction is of major importance in regards to the performance and life of plant equipment. Although the internal properties (i.e. the internal friction angle, the unconfined strength) are important for the design of silos or bins and hoppers, often the interaction between bulk solids and wall surfaces are the key source of flow problems such as material hang-ups, cohesive arching and flooding. The rate of wear of liners and walls in bins or chutes is greatly dependent on the kinematic friction angle and typically governs the life of linings in plant equipment [1]. Wall friction is traditionally measured using a Jenike direct shear tester and an annular shear cell tester as described by Schwedes [2]. The Jenike shear tester setup for measuring wall friction as shown in Fig. 1 is a popular tool used to analyse the kinematic wall friction angles and cohesion of a bulk solid when slid on a surface as described in the Standard Shear Testing Technique (SSTT) [3].



**Fig. 1** Schematic of the standard Jenike wall friction test arrangement

The Jenike shear tester consists of a shear ring with an inside diameter of 95.25mm which retains the bulk material that is placed into the shear cell and consolidated against a flat wall material by a shear cell lid under a perpendicular normal force. Numerous points on a wall yield locus (WYL) are determined by shearing a bulk material under a monotonically decreasing normal force on a wall sample at a constant shear rate between 2 and 3mm/min. The limitation of the Jenike shear tester is the restriction on the top size of the particles. According to the SSTT the Jenike shear tester is suitable for coarse particles with a diameter up to 5 percent of the shear cell diameter but typically particles above 4mm are removed. Removing the coarser particles has been accepted as a valid technique to obtain reliable and conservative wall friction angles as the fine particles are of more interest for determining the maximum strength and boundary friction of a bulk solid, especially to achieve mass flow bins [4]. Particles with a diameter of approximately 10mm are possible to test on the Jenike tester to measure wall friction angles but become more difficult and time consuming to test. With larger particles in the shear cell the ability to properly prepare and consolidate the material decreases and obtaining consistent shear points becomes more difficult and time consuming exemplifying the limitation of the standard Jenike shear tester.

To measure wall friction of a bulk solid over the full particle size distribution with representative properties, Pillai et al. [5; 6] developed an on-line wall friction tester where two wall “skid” plates slid on the surface of the bulk material on a belt conveyor to primarily assess the instantaneous flowability of the bulk material. The normal pressures applied to the “skid” plates on the on-line tester were low but the inability to reliably preconsolidate the material and possible segregation made it difficult to replicate the test conditions between the on-line tester and off-line Jenike shear tester and achieve good correlations for various grades of coal [6]. However, the ability to measure wall friction of a bulk solid to indicate the changes in handleability has potential value in the bulk materials industry especially if minimal sample preparation is required (i.e. screening, moisture checks and wetting). The conservative approach of measuring flow properties based on the “worst case” is not always ideal, for example measuring the highest wall friction angle to design chutes with the greatest inclination angle or cut-off angle to ensure reliable flow and self cleaning may exacerbate wear or flooding problems due to excessive stream velocities if friction angles are over predicted. Correctly measuring friction angles of bulk solids to analyse bulk material flow using analytical (e.g. chute flow model [7]) or numerical models (e.g. discrete element method) using representative moisture contents, particle size distributions and other properties is important to adequately design equipment for the environmental conditions and a larger wall friction tester has the potential to conduct the required experiments.

The interaction of bulk solids with surfaces is influenced from a range of factors related to the bulk solid, wall material and environmental conditions. Below is list of key factors which influence wall friction:

- Surface roughness [8]
- Particle size and size distribution [8-10]
- Moisture content [8]
- Particle shape
- Normal pressure applied between the bulk solid and surface [8-10]
- Rate of shear between the bulk solid and surface [5; 8]

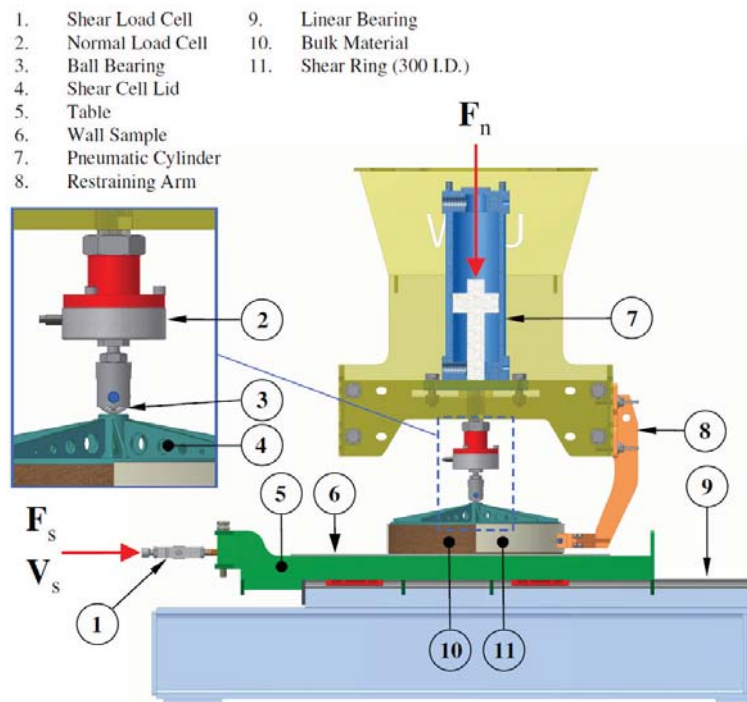
Apart from the factors listed above the displacement of the bulk solid where measurements are taken has also been observed to influence the wall friction angle [11]. Typically the standard Jenike shear tester has a limited distance the stem can travel ( $\approx 10\text{mm}$ ) restricting the period of steady-state shear where measurements can be taken. The annular shear cell unlike the Jenike shear tester has the capability to shear bulk solids over a longer distance.

Scott and Keys [10] developed a large scale inverted wall friction tester to measure the wall friction of different size coal particles up to 30mm. Using a shear ring with an inside diameter 305mm and depth of 80mm, bulk material was placed into the stationary inverted shear cell and pressed underneath the wall sample using pneumatic cylinders while the wall sample was sheared over the bulk material. Comparisons between the standard Jenike shear tester and the large inverted wall friction tester using minus 4mm particles and the same wall samples showed similar results but the wall friction angles measured on the large wall friction tester were marginally higher.

This paper outlines the design and commissioning of a novel large scale wall friction tester which has been designed based on the Jenike wall friction tester concept. Wall friction angles measured from the standard and large scale wall friction tester have been compared using cohesionless and cohesive bulk material of varying size distributions to validate the large scale tester and investigate the effects of particle size.

## 2 DESIGN AND LAYOUT OF THE LSWFT

The LSWFT has been designed based on the principle originally developed by Jenike [12] shown in Fig. 1 where the bulk material is placed into a shear ring and sheared on top of a wall sample under a monotonically decreasing normal force  $F_n$ . The SSTT was used as a guide on the required dimensions and layout of the machine to conduct successful wall friction tests according to the specified procedure. Figure 2 shows the general layout of the primary parts of the test rig. To make this test rig safe and easy to use several key aspects which are employed in the standard Jenike shear tester have been modified to make the test rig functional. Typically the normal force is applied to the shear cell lid using a hanger with dead weights which moves with the shear cell on top of the wall sample. Handling over a 100kg of weights becomes a safety issue and involves a lot of manual handling which is undesirable and design of a mechanical advantage system becomes complicated and can create superfluous errors. Instead a pneumatic cylinder was adopted to apply the normal force to the shear cell lid and using a load cell to measure the applied force. The best option to shear the bulk material along the wall sample was to keep the pneumatic cylinder and shear cell stationary while the wall sample was translated underneath the bulk material supported by linear bearings.



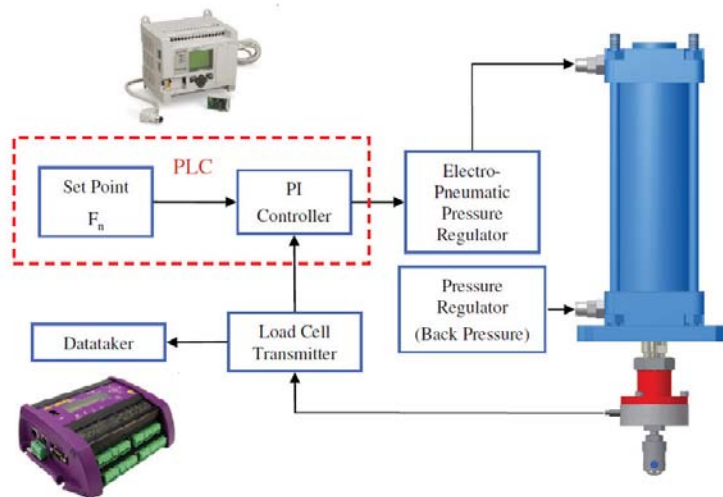
**Fig. 2** Schematic of the LSWFT arrangement

The dimensions of the shear ring were determined by scaling up the dimensions of the standard shear cell where a ring with an inside diameter (I.D.) of 300mm and a depth of 50mm was chosen. Based on these dimensions the tolerable particle top size is between 15 and 20mm according to the SSTT guidelines. The wall sample (500mm square or 600x500mm) is secured to the table using toggle chams and fasteners where the table is either pulled or pushed by a linear actuator driven by a servomotor and servo drive at a constant shear rate. The servo drive allows the shear rate to be accurately set and controlled using feedback from the servomotor to continually check the motor speed and adjust the motor speed if required after tuning. The linear actuator can operate at shear rates  $V_s$  between 2.54 and 50mm/min (standard Jenike tester operates between 2.69 and 2.72mm/min) over the 150mm travel distance. Higher shear rates are possible but are restricted due to the maximum travel distance. The shear force applied to the linear actuator as shown in Fig. 2 is measured using an S-type compression/tension load cell which is directly connected to a Datataker DT80 [13] acquisition system to nominally record data at 4 readings per second. To allow for vertical movement of the shear ring over uneven wall sample surfaces due to the preparation of sample specimens, the shear cell has been designed to float up and down over high or low sections on the wall sample using ball bearings on a “V” shaped restraining arm shown in Fig. 2. The restraining arm can be adjusted vertically to compensate for various thickness wall specimens and has been designed to help centralise the shear ring as the bulk material shears along the wall sample.

The general operations of the LSWFT are controlled by a PLC (Programmable logic controller) to consolidate the bulk material, begin the test procedure, retract and extend the table and pneumatic ram and set all the test variables (i.e. shear rate, normal force range, controller constants, jog speeds etc). Due to the extended shear travel and the ability to obtain long steady-state shear periods, the machine can be operated to semi-automatic or fully automatic (if selected) to step down the normal force once steady-state conditions have occurred. The maximum normal and shear stresses which can be applied to the 300mm I.D. shear cell are approximately 35kPa (250kg) and 28kPa (200kg), respectively.

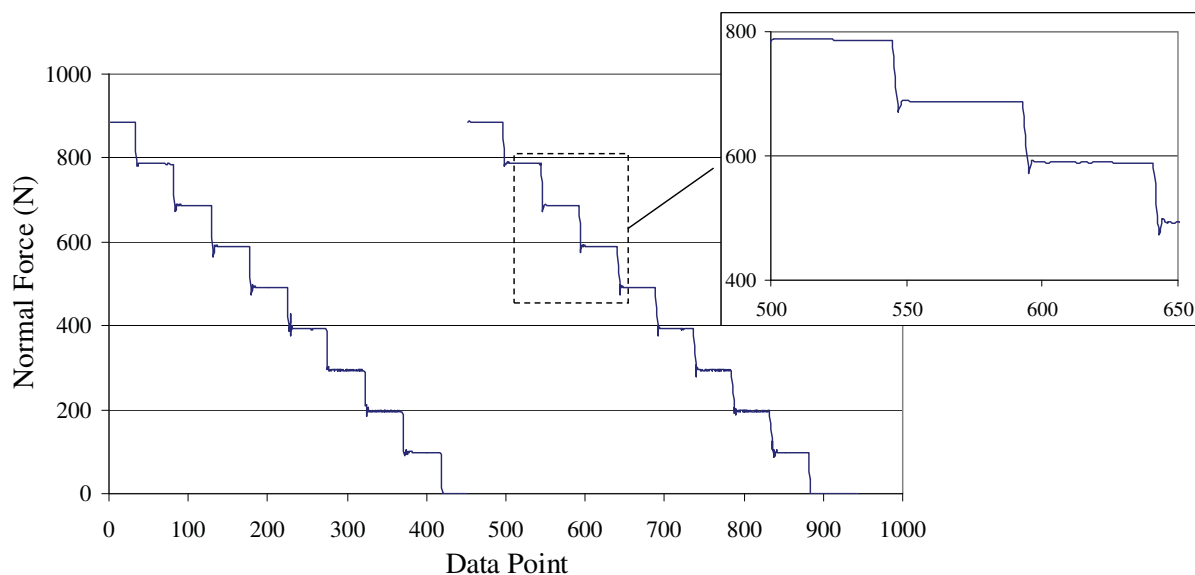
## 2.1 Application and control of the normal force

The application of the normal force on top of the bulk material is crucial for accurate and steady results. The system to apply and control the normal force needed to be robust and be able to achieve stable forces under transient conditions where the pneumatic ram is allowed to float over small displacements as the shear cell lid moves up and down. The system must also be able to respond quickly to changes in the normal force or set point with minimal overshoot and steady-state error. Figure 3 outlines the basic equipment and layout of the system which is used to apply and control the normal force. Once the ball bearing attached to a load cell on the end of a pneumatic cylinder is in contact with the shear cell lid, the force is regulated by an electro-pneumatic pressure regulator which is controlled by a PLC. A proportional-integral (PI) controller has been setup within the PLC to control the system set point ( $F_n$ ) using feedback from the load cell. Back pressure has been added into the bottom of the cylinder to achieve accurate and low normal forces (counter-acting the suspended mass). A series of valves has been used to control the position of the pneumatic cylinder and relieve the pressure within the cylinder quickly. The ball bearing attached to the load cell minimises the shear force at the load cell which improves the general control of the system and the measured wall friction angles.



**Fig. 3** Control and measurement of the normal force applied to the shear cell lid

After accurate tuning of the PI controller and calibration of the normal load cell, the electro-pneumatic regulator has the capability to quickly respond to a change in the set point within several seconds as illustrated in Fig. 4 with minimal overshoot during the unit-step response. Even when the shear lid and/or shear cell floats up or down due to the compaction of the bulk material or an uneven wall sample surface, the pneumatic cylinder and the PI controller can maintain a reasonably constant normal force on the shear lid. As shown in Fig. 4 using trihydrate grade bauxite with a particle top size of 16mm as the test bulk material, the variation of the normal force is typically below 1N for a coarse bulk material and greatly improves for finer bulk materials (<0.5N). These minor fluctuations of the normal force have negligible effects on the shear force and the instantaneous normal and shear force are recorded and used for data analysis. Therefore, the system which applies the normal force onto the shear cell provides reliable results with minor tolerable errors.



**Fig. 4** Sample of normal force output decreasing from 882.9 N to 0 N with 98.1 N increments; bulk material: trihydrate grade bauxite ( $d < 16\text{mm}$ ), wall sample: stainless steel 304-2B

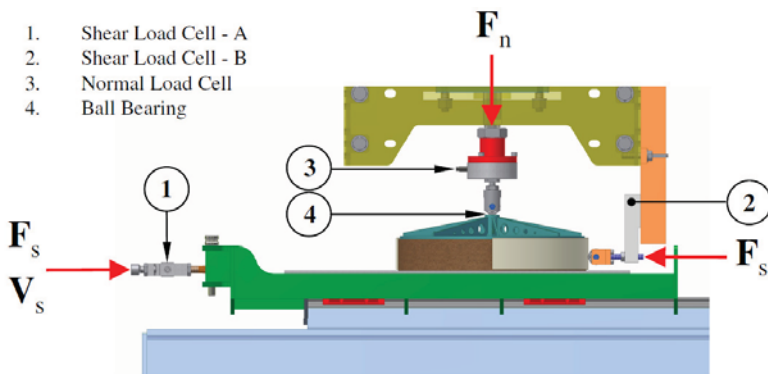
## 2.2 Calibration of the linear bearings and validation of the shear force measuring technique

Measurement of the shear force  $F_s$  is the critical aspect of any wall friction tester. The use of linear bearings to support the table requires a method to remove the small shear resistance from the seals on the runner blocks. It is observed that the main resistance in the linear bearings is from the seals which has a minor dependency on the normal force on top of the table. When the table initially begins to move the shear force either increases or decreases from pre-loads on the bearings which eventually stabilise to a reasonably constant force. However, the period where the forces in the bearings stabilise is typically the stage where the bulk material is being sheared with the initial maximum normal force which generally takes a long time to reach steady-state shear force that is ignored in the calculation of the wall friction angle according to the SSTT.

Before a wall friction test is commenced, the average force to push or pull the table is measured and taken as the zero point for all the shear points during the test. The deviation of the shear force in the linear bearings is typically  $\pm 0.03\text{kPa}$  (300 I.D cell) which is tolerable considering the variations of results generally present when testing flow properties of bulk materials. During the assembly of the linear bearings and the attachment of the runner blocks to the table, care was taken to ensure that the rails were parallel and that the motion of the table was as smooth running as possible. The end caps which cap off the holes on the rails were carefully placed to ensure that the seals on the runner blocks did not interfere with the caps. Although the measured shear force in the linear bearings fluctuates, the data acquisition system (i.e. Datalogger DT80) and load cells do experience a small degree of creep under load and with all environmental conditions and other variables remaining constant. The specified creep of the shear load cell ① shown in Fig. 2 is 0.023% of the rated load (0.45N) and the measured combined creep of the Datalogger and load cell is approximately 0.051% (1N) of the rated load of the S-type load cell. Therefore, considering the creep in the data acquisition system, the resistance force in the linear bearings is almost constant, however the measured shear force is calibrated to accurately determine the actual shear force at the shear plane.

To validate the shear force measured from the load cell attached to the table as shown by ① in Fig. 5a and develop a model to evaluate the shear force in the linear bearings, a second load cell has been placed in contact with the shear ring or plate sample (Fig. 5b) shown by ② in Fig. 5a to measure the shear force at the restraining point. As a ball bearing has been

placed under the normal load cell to create a roller connection, the shear force at location ① and ② should be equal or very close.

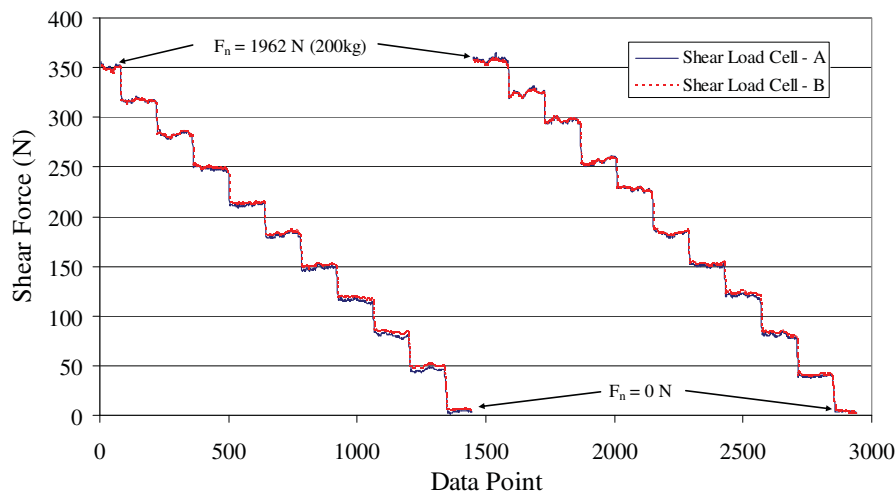


**Fig. 5a** Schematic of shear force measurement techniques



**Fig. 5b** Validation of shear force measurements

Figure 6 shows a comparison of the shear forces measured from load ① and ② in Fig. 5a when an aluminium plate is sheared on top of a smooth mild steel sheet at 2.54mm/min under a normal load varying from 200 to 0 kg as shown in Fig. 5b. The shear force measured in Fig. 6 using load cell ① has been compensated using a basic model to determine the small amount of friction in the linear bearings based on the instantaneous normal force on the shear plane. Figure 6 shows that the error between the shear force measured at the two different locations after correct calibration is small. The addition of the second load cell ② at the point of contact with the shear ring allows additional data to be collected to compare with the primary shear load cell ① and increase the confidence of the results and wall friction angles.



**Fig. 6** Comparison of shear force measured from location A and B of test arrangement shown in Fig. 5b. Wall samples: aluminium plate sliding on top of a smooth mild steel sheet;  $F_n = 1962 \text{ N}$  to  $0 \text{ N}$  (196.2 N increments)

### 2.3 Material used

Linear low density polyethylene pellets (PP) [14] and trihydrate grade bauxite (TGB) were selected to validate the LSWFT or compare measured wall friction angles against the Jenike shear tester. The polyethylene pellets are robust, dustless, reasonably mono-sized and regular in particle shape. The TGB is a unique material which consists of hard spheroids with a particle diameter between approximately 2mm and 9mm and irregular shaped particles above a diameter of 9mm. The TGB also consists of a high proportion of fine sticky fines which give the material greater ability to form a stable arch. Details of the bulk material particle size and mass % below 4mm are listed in Table 1.



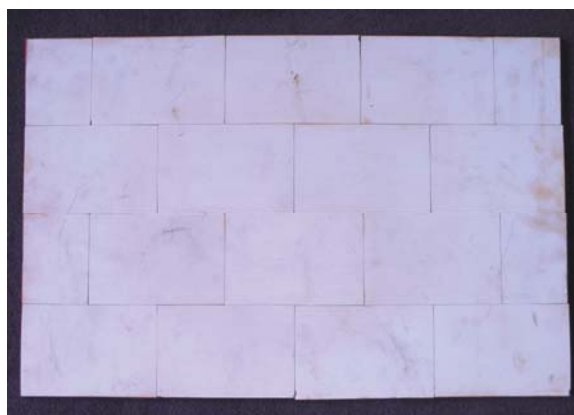
**Table 1** Summary of the bulk materials particle size distribution

Bulk material	Average particle diameter $d_{avg}$ (mm)	Bottom size (mm)	Top size (mm)	Mass % under 4mm
Trihydrate grade bauxite (TGB)	4.87	<0.106	16	32
Polyethylene pellets (PP)	4.55	3.35	5.6	0.7

A variety of wall samples was selected with varying surface roughness to examine the effects of surface roughness and surface preparation on the kinematic wall friction angle. Details of the wall samples used on the Jenike tester and the LSWFT are listed in Table 2 which range from smooth stainless steel 304 grade with a surface finish of “2B” to rough Bisalloy 400. One significant feature of the LSWFT is the ability to test large wall sample materials. The effects of joints between tiles as shown in Fig. 7 or welded joints between plates or corrugated surfaces of wear liners also can be investigated. As ceramic wear resistant liners are typically manufactured as small tiles or blocks, a specimen sheet was made by gluing the tiles onto a plate as shown in Fig. 7 which was used on the LSWFT. The wall friction tests on the ceramic tile on the Jenike tester were conducted using a single tile.

**Table 2** Summary of the wall sample plate used on the Jenike shear tester and the LSWFT

Wall material	Dimensions (mm)	Roughness ( $\mu\text{m}$ )
Stainless steel 304 – 2B finish	150x150x3, 500x400x3	0.333
CUMITUFF ceramic wear resistant tiles (92% alumina content)	150x100x6, 600x400x6	1.37
Matrox classic - pressed	150x150x12, 500x400x12	1.58
Bisalloy 400 or Bisplate 400 – quenched and tempered	150x150x10, 500x500x10	4.91

**Fig. 7** Large wall sample of CUMITUFF ceramic wear resistant tiles 600x400x6mm (92% alumina content)

## 2.4 Test procedure

The test procedure adopted for this investigation is outlined in the SSTT. The surfaces of the wall materials were cleaned using a damp cloth with water and dried using tissue paper. The wall surfaces were “conditioned” prior to testing by rubbing the bulk material (except the polyethylene pellets) into the surface by hand. On the LSWFT the wall surface was additionally “conditioned” by half filling the large shear ring with material and shearing ( $10\text{mm}/\text{min} < V_s < 30\text{mm}/\text{min}$ ) the material against the wall surface under a constant normal force. Previous research [5; 11] has shown that the highest wall friction angles are measured once at least 10m worth of rubbing/sliding the bulk material against the wall surface has been performed. However, with the arrangement of the Jenike tester and LSWFT, conducting the latter “conditioning” would be extremely time consuming so the SSTT procedure was followed where possible.

Once the maximum normal force was applied to the shear cell, the shear ring was slightly lifted by twisting the ring to ensure there was no contact between the ring and wall material similar to the SSTT procedure. Typically the horizontal pressure exerted by the bulk material on the shear ring was sufficient to support the shear ring and prevent the ring from contacting the wall material.

On the LSWFT some of the procedures that were used on the Jenike tester were modified due to limitations of the test rig and to make tests quicker to perform as well as to achieve consistent results. Some of the key modifications in test procedure on the LSWFT were:

- The bulk material was poured into the shear ring using a mould ring and levelled off. As it was not possible to apply a high normal force onto the shear cell lid and twist the lid until the sample is homogenised, the lid was twisted by hand with a small amount of normal force (applied by hand) and then the bulk material was compressed with 28kPa of normal pressure. The excess material is scraped off level. It was observed that generally the first shear point would take longer to reach steady-state conditions as the bulk material consolidated.
- Once a test run was complete and the shear points from the maximum to the lowest normal pressures were measured, the table was not retracted and the shear ring pushed back. Instead the table was slightly retracted to relief the shear force back to zero and another test was commenced where this procedure was repeated until consistent shear points were measured. It was observed that pushing back the shear ring full of material was difficult without unconsolidating the sample. When the sample became unconsolidated it took longer and was difficult to achieve consistent results.

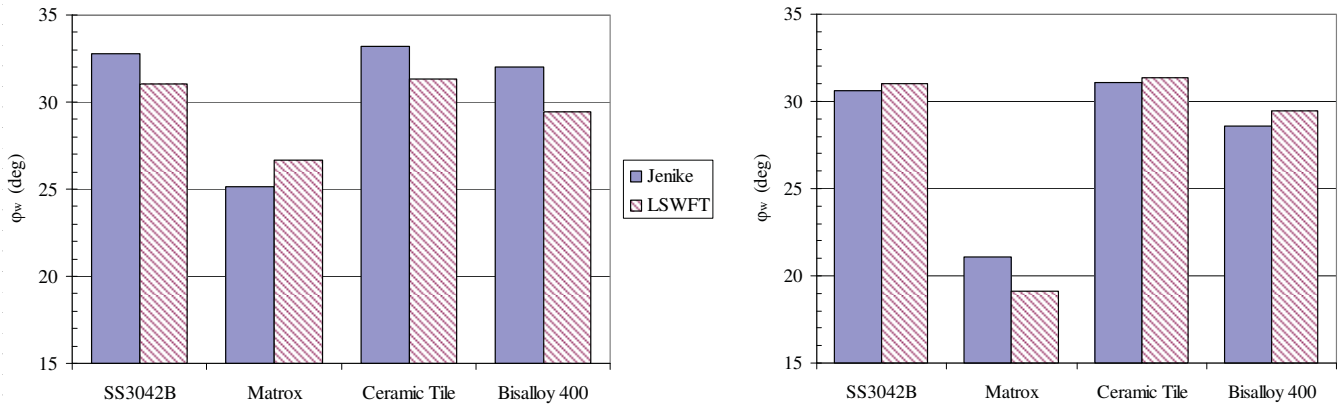
In this investigation the polyethylene pellets were tested as “bulk” (i.e. full particle size distribution) and the trihydrate grade bauxite was tested in two size ranges; minus 4mm and “bulk”. Testing the bauxite in two size ranges allowed for a direct comparison of the Jenike tester and LSWFT (i.e. using minus 4mm particles) and the difference between the wall friction angles measured using different particle top sizes to be examined on various wall materials. The TGB was also tested dry and wet at 16% wet basis (wb) moisture content (only for bulk particle size distribution).

### **3 RESULTS AND DISCUSSION**

Measuring wall friction angles of bulk materials which contain coarse particles with a diameter greater than 4mm is possible on a Jenike shear tester but difficulty of obtaining consistent results increases. The polyethylene pellets are considered to be approaching the upper limit of testable bulk materials on the Jenike shear tester according to the SSTT for internal shear tests. The ability to obtain reliable wall friction angles of the polyethylene pellets on various wall samples was relatively simple. To make it easier to test the TGB in “bulk”, coarse particles with a diameter approximately greater than 8 mm were pickled to allow the shear cell to be adequately filled and consolidated. The ability to obtain repetitive or similar shear point values when testing the coarse TGB was difficult and time consuming on the Jenike tester.

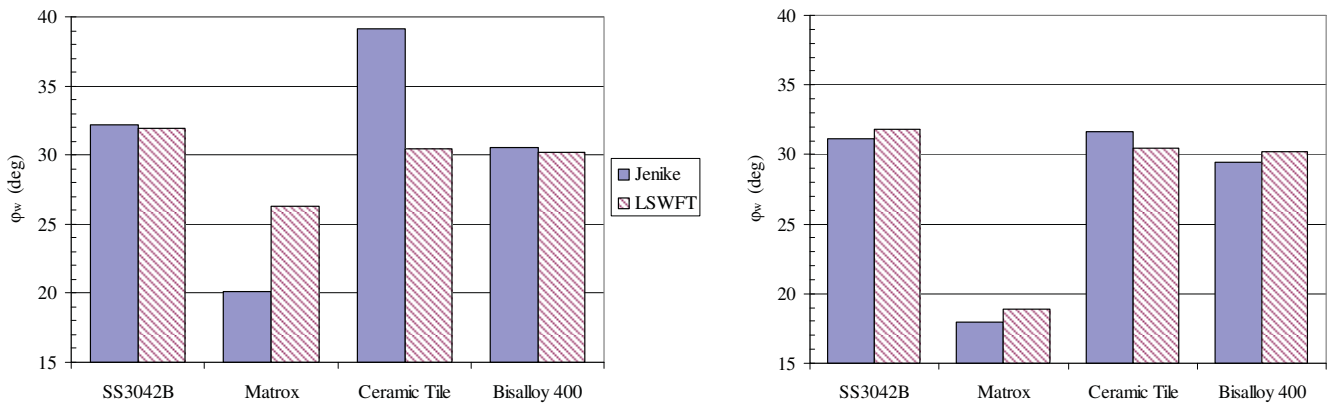
Figures 8 to 11 show the calculated kinematic angles of wall friction measured from the average wall yield loci determined from numerous tests where the bulk material sample was replaced to examine the variation in the wall yield loci. As the kinematic angle of wall friction typically decreases as the normal pressure increases, the wall friction angle has been

evaluated at a low (1 kPa) and high (10kPa) normal pressures. To evaluate the accuracy of the LSWFT, the minus 4mm TGB sample was tested on the four wall sample materials listed in Table 2. The correlation between the wall friction angles in Fig. 8 at high normal pressures is relatively good for all the wall samples but there is some variation of the wall friction angle measured at a low normal pressure. When the TGB is dry, the material is free flowing and displays minimal cohesion especially on the LSWFT where the wall friction angles measured at low pressure on the LSWFT are lower than those measured on the Jenike tester.

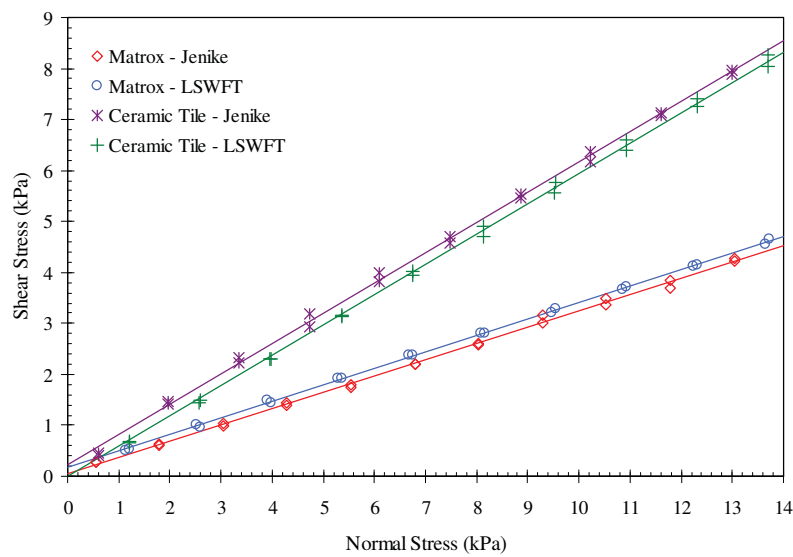


**Fig. 8** Variation of kinematic wall friction angle  $\phi_w$ : normal stress = 1 kPa (left), 10kPa (right); material = TGB minus 4mm; moisture content = 0%wb

When the TGB was tested on the LSWFT as a “bulk” sample, the behaviour of the material during each test was more stable and less erratic fluctuations of the shear force occurred as compared to the behaviour observed when testing the material on the Jenike tester. The measured shear force on the LSWFT was not as sensitive to coarse particles compared to the Jenike tester. Figures 9 and 10 show the measured wall friction angles and wall yield loci for various wall materials for dry TGB tested as a “bulk” sample. The measured wall friction angles in Fig. 9 are similar when the normal pressure is high (10kPa) and reasonably similar at low normal pressures with the exception of the ceramic tiles and matrox where the difference is greater than 5 degrees. The measured wall yield loci in Fig. 10 shows minor deviations between the Jenike tester and LSWFT. The line of best has been determined using linear function which has traditionally been satisfactory to fit to shear points especially at high pressures. However, as shown in Figs. 10 and 12 the lowest shear points of the TGB on the ceramic tile measured on the Jenike tester tends to have a higher fitting error compared to other shear points. As the lowest shear point is situated below the WYL, the measured wall friction angle based on the fitted WYL is over estimated. As more bulk material is used in the LSWFT (i.e. 300 I.D. shear ring), the lowest normal pressure achievable on the LSWFT is higher compared to Jenike tester’s capability. The difference between the wall friction angles measured using two different top sizes (i.e. 4mm and 16mm) on either the Jenike tester or the LSWFT is minor as shown between Figs. 8 and 9.



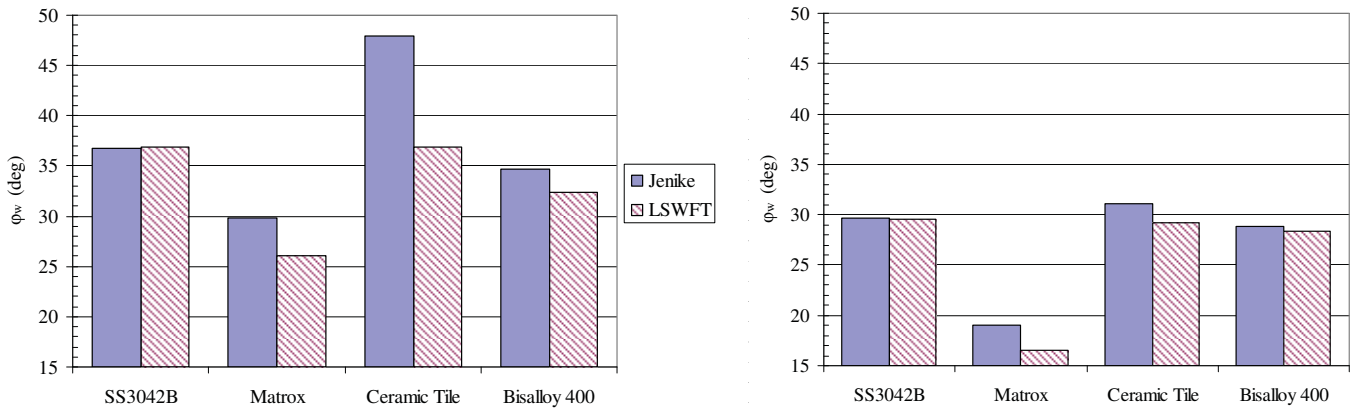
**Fig. 9** Variation of kinematic wall friction angle  $\phi_w$ : normal stress = 1 kPa (left), 10kPa (right); material = TGB bulk; moisture content = 0%wb



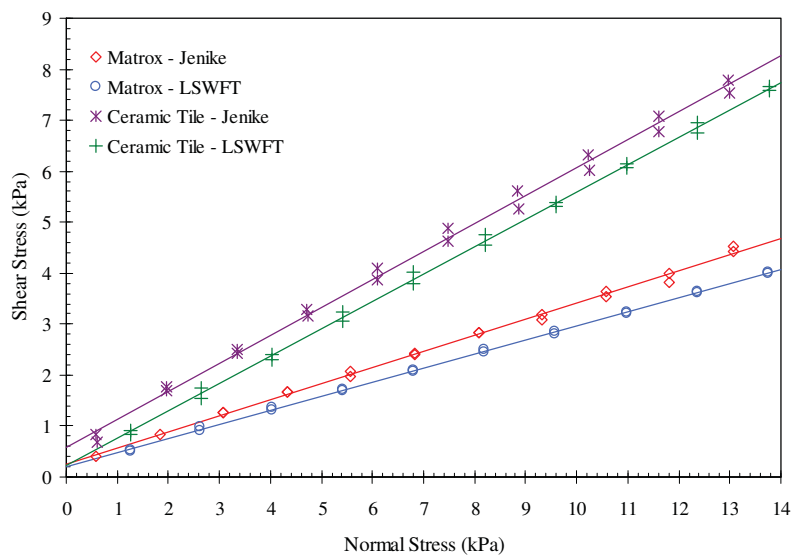
**Fig. 10** Wall yield loci on various wall samples; material = TGB bulk; moisture content = 0%wb

The ability of a bulk material to stick to surfaces is an important aspect to consider when designing equipment to store or handle cohesive materials. A limitation of a standard Jenike type tester is the capability to measure shear points under low or no normal force which results in the cohesion being approximated by extrapolating the WYL to the interaction point on the shear (ordinate) axis. To examine the ability of the LSWFT to accurately predict the cohesion stress and the increase of the wall friction angles at low normal pressures, the “bulk” sample of TGB has been wetted up to 16% wb moisture content where the results of the wall friction tests are shown in Figs. 11 and 12.

The wall friction angles measured with the Jenike tester are basically the same as those measured by the LSWFT or slightly larger with exception of the friction angle measured on the ceramic tile at low normal pressure as shown in Fig. 11. The predicted cohesion when wet TGB slides on matrox shown in Fig. 12 is similar between both wall friction testers but the gradient of the WYL from the Jenike tester is greater. Likewise the WYL of the TGB on the ceramic tile is above the WYL from the LSWFT but the cohesion stress predicted from the Jenike tester is greater compared to the LSWFT. Comparing Figs. 9 and 11, the greatest change of the wall friction angles have occurred at the low normal pressure range where the reduction of the wall friction angles at high normal pressures is minor.



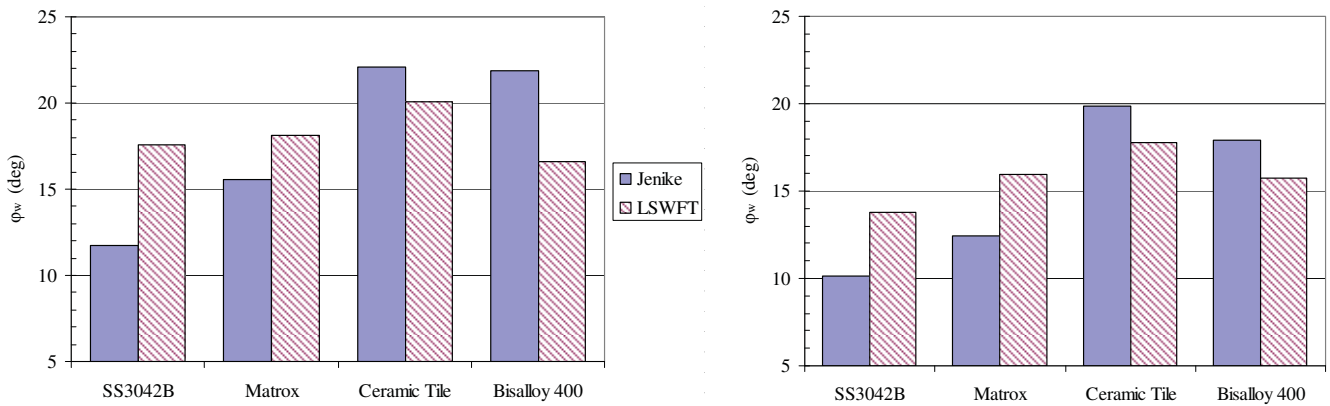
**Fig. 11** Variation of kinematic wall friction angle  $\phi_w$ : normal stress = 1 kPa (left), 10kPa (right); material = TGB bulk; moisture content = 16%wb



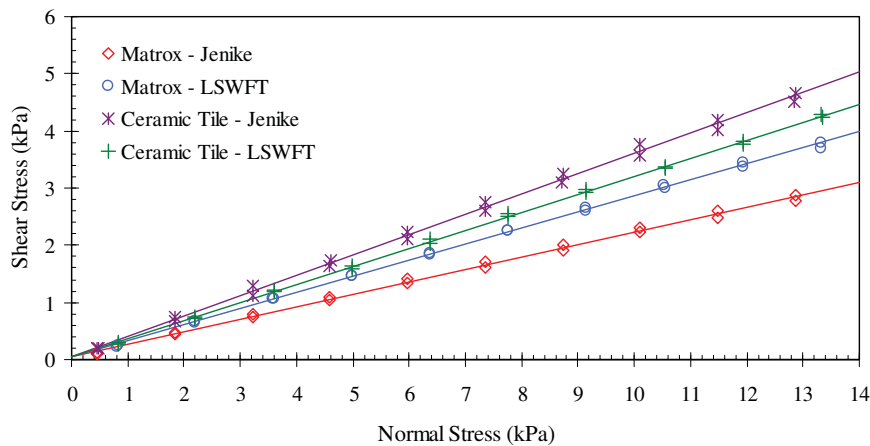
**Fig. 12** Wall yield loci on various wall samples; material = TGB bulk; moisture content = 16%wb

The polyethylene pellets are relatively simple to test and are relatively cohesionless at low shear rates. Figures 13 and 14 show the measured wall friction angles and wall yield loci of polyethylene pellets on various wall materials. The correlation between the wall friction angles measured on the Jenike tester and LSWFT do not compare as well as the TGB results (Figs. 8 and 9). For smooth wall materials (i.e. SS304 2B and matrox), higher wall friction angles are predicted on the LSWFT while lower friction angles are predicted on rougher materials (i.e. Ceramic tile(s), Bisalloy 400) on the LSWFT. The variation of the friction angle of the polyethylene pellets ranges up to 4 and 6 degrees at high and low normal pressures, respectively which can increase the tolerance of bin inclination angles or hopper half angles to ensure self cleaning or minor variations of calculated material stream velocities in chutes.

Reviewing the wall friction angles measured on a ceramic tile or ceramic tiles (Fig. 7), the effects of non-flat tiles and joints between the tiles which create raised edges or lips are not significant on the kinematic wall friction angle as the wall friction angles measured on the LSWFT are generally lower than those measured on Jenike machine using a single tile. As the height of the lips are generally small with respect to the average particle diameter, particles easily slide over the lips or minimal fine material is built up at the joint which does not dramatically increase the bulk force to shear the material.



**Fig. 13** Variation of kinematic wall friction angle  $\phi_w$ : normal stress = 1 kPa (left), 10kPa (right); material = PP; moisture content = 0%wb



**Fig. 14** Wall yield loci on various wall samples; material = PP; moisture content = 0%wb

The “best” wall friction characteristics were displayed by the TGB and polyethylene pellets samples on the matrox classic which is a popular lining material for flow promotion. The polyethylene pellets sample also displayed good wall friction characteristics on the stainless steel 304-2B but significantly higher wall friction angles were exhibited by the TGB on the stainless steel 304-2B compared with the matrox.

#### 4 CONCLUSIONS AND FUTURE WORK

The work presented in this paper has outlined the design and commissioning of the new LSWFT to achieve reliable results. After a comprehensive commissioning period where various parts of the LSWFT were modified, repeatable and realistic results were obtained which were satisfactory compared to the measurements from the Jenike direct shear tester. The LSWFT was validated to check that the normal force application was accurate and reasonably constant during testing. The method of measuring the shear force at the shear plane was shown to be accurate once the resistances in the linear bearings were calibrated. The general correlation of the measured wall friction angles and wall yield loci between the Jenike tester and the LSWFT using similar combinations of bulk material, particle size distribution and wall material was good. Although the correlation between measured wall friction angles of the polyethylene pellets were marginally dissimilar between the two wall friction testers, the size of the polyethylene pellets was close to the upper suggested limit of testable materials on the Jenike tester. This may have affected the accuracy of the results.

The results presented in this paper are based on preliminary tests on a small selection of wall samples. This limits the ability to comprehensively quantify and assess the accuracy of the LSWFT. Further investigations are still required to test a wider range of bulk materials and wall material combinations to assess the effects of particle size, moisture content, shear rates, particle shape, compressibility and surface roughness. The LSWFT has the potential to test with greater ease more representative particle size distributions (i.e. with less or no pickling required) and moisture contents.

## Acknowledgements

A.P. Grima is grateful to Technological Resources Pty. Ltd. (subsidiary of Rio Tinto Ltd.) for the financial support (scholarship) for the present work. The authors also thank Brent Percy, Ian Frew, Wendy Halford, Emeritus Professor Peter Arnold and the workshop at the University of Wollongong for their assistance in the design and manufacture of the LSWFT.

## References

- [1] A. W. Roberts & S. Wiche, Prediction of lining wear life of bins and chutes in bulk solids handling operations, *Tribology International*, Vol. 26, No. 5, 1993, pp. 345-51.
- [2] J. Schwedes, Review on testers for measuring flow properties of bulk solids, *Granular Matter*, Vol. 5, No. 1, 2003, pp. 1-43.
- [3] Institution of Chemical Engineers, Standard shear testing technique for particulate solids using the Jenike shear cell: A report of the EFCE Working Party on the Mechanics of Particulate Solids, Rugby, England, Institution of Chemical Engineers, 1989.
- [4] W. J. B. van den Bergh & B. Scarlett, Influence of particle breakage on the wall friction coefficient of brittle particulate solids: Part 1. Influence of wall inclination, normal load and displacement, *Powder Technology*, Vol. 67, No. 3, 1991, pp. 237-47.
- [5] J. R. Pillai, M. S. A. Bradley & R. J. Berry, Comparison between the angles of wall friction measured on an on-line wall friction tester and the Jenike wall friction tester, *Powder Technology*, Vol. 174, No. 1-2, 2007, pp. 64-70.
- [6] J. R. Pillai, M. S. A. Bradley, R. J. Berry & A. R. Reed, Development of an Industrial On-line Powder Flowability Tester, Results from Industrial Trials, in Proceedings of the 6th International Conference for Conveying and Handling of Particulate Solids (CHoPS), Brisbane, Queensland, Australia, 3-7 August, 2009, Proceedings on USB, pp. 478-83.
- [7] A. W. Roberts, Chute performance and design for rapid flow conditions, *Chemical Engineering and Technology*, Vol. 26, No. 2, 2003, pp. 163-70.
- [8] A. W. Roberts, L. A. Sollie & S. R. de Silva, Interaction of bulk solid characteristics and surface parameters in surface or boundary friction measurements, *Tribology International*, Vol. 26, No. 5, 1993, pp. 335-43.
- [9] J. K. Prescott, D. A. Ploof & J. W. Carson, Developing a Better Understanding of Wall Friction, *Powder Handling and Processing*, Vol. 11, No. 1, 1999, pp. 27-36.
- [10] O. J. Scott & S. Keys, The Variation of Boundary Friction for Granular Products, in Proceedings of the 4th International Conference on Bulk Materials Storage, Handling and Transportation (ICBMH 92), Wollongong, Australia, 1992, pp. 279-86.
- [11] M. S. A. Bradley & R. J. Berry, Evolution of Wall Friction with Realistic Displacements Wall "Conditioning" and the need to Measure Wall Friction Over a Long Distance of Travel, in Proceedings of the 6th International Conference for Conveying and Handling of Particulate Solids (CHoPS), Brisbane, Queensland, Australia, 3-7 August, 2009, Proceedings on USB, pp. 434-39.
- [12] A. W. Jenike, Storage and flow of solids, *Bull. No. 123, Engng. Exp. Station, University of Utah, Salt Lake City*, 1964.
- [13] Thermo Fisher Scientific Australia Pty Ltd, DT80 User's Manual, Victoria, Australia, Thermo Fisher Scientific Australia Pty Ltd, 2009.
- [14] Qenos, Technical Information: Alkatuff Polyethylene-Grade LL0130AB, Victoria, Australia, Qenos Pty Ltd, 2005.