



UNIVERSITY  
OF WOLLONGONG  
AUSTRALIA

University of Wollongong  
Research Online

---

Faculty of Engineering and Information Sciences -  
Papers: Part A

Faculty of Engineering and Information Sciences

---

2009

# Adoption of dynamic simulation for energy performance rating tool for Korean residential buildings: EDEM-SAMSUNG

Saeeta Ghauri  
*University of Strathclyde*

Cameron Johnstone  
*University of Strathclyde*

Jaemin Kim  
*University of Strathclyde*

Georgios Kokogiannakis  
*University of Wollongong, gkg@uow.edu.au*

Paul Tuohy  
*University of Strathclyde*

*See next page for additional authors*

---

## Publication Details

Ghauri, S., Johnstone, C., Kim, J., Kokogiannakis, G., Tuohy, P. & Woo, K. (2009). Adoption of dynamic simulation for energy performance rating tool for Korean residential buildings: EDEM-SAMSUNG. 11th International Building Performance Simulation Association Conference (IBPSA 2009) (pp. 2070-2076). United Kingdom: University of Strathclyde.

Research Online is the open access institutional repository for the University of Wollongong. For further information contact the UOW Library: [research-pubs@uow.edu.au](mailto:research-pubs@uow.edu.au)

---

# Adoption of dynamic simulation for energy performance rating tool for Korean residential buildings: EDEM-SAMSUNG

## **Abstract**

Currently, there is a high emphasis on reducing the energy consumption and carbon emissions of buildings worldwide. Korea is facing an emerging issue of energy savings in buildings in perspective of new green economic policy. In this context, various policy measures including the energy efficiency ratings for buildings are being implemented for domestic and non-domestic buildings. In practice, design teams tend to prefer easy to use assessment tools to optimise energy performance and carbon ratings while they are concerned about calculation accuracy and the accurate representation of the dynamics involved associated with the characteristics of Korean residential buildings. This paper presents an assessment tool, named 'EDEM-Samsung' that aims to address these challenges for Korean residential apartments, which often encounter complex design issues. EDEM-Samsung is a tool that enables users to make rapid decisions identifying the effect of design parameter changes on energy and carbon ratings with an effective user interface and without compromising accuracy. This paper describes the architecture and functionalities of the tool, and the advantages offered to Korean designers.

## **Keywords**

korean, residential, buildings, edem, samsung, adoption, simulation, dynamic, energy, performance, rating, tool

## **Disciplines**

Engineering | Science and Technology Studies

## **Publication Details**

Ghuri, S., Johnstone, C., Kim, J., Kokogiannakis, G., Tuohy, P. & Woo, K. (2009). Adoption of dynamic simulation for energy performance rating tool for Korean residential buildings: EDEM-SAMSUNG. 11th International Building Performance Simulation Association Conference (IBPSA 2009) (pp. 2070-2076). United Kingdom: University of Strathclyde.

## **Authors**

Saeeta Ghuri, Cameron Johnstone, Jaemin Kim, Georgios Kokogiannakis, Paul Tuohy, and Kyung-Hun Woo

## **ADOPTION OF DYNAMIC SIMULATION FOR AN ENERGY PERFORMANCE RATING TOOL FOR KOREAN RESIDENTIAL BUILDINGS: EDEM-SAMSUNG**

Sabeeta Ghauri<sup>1</sup>, Jon Hand<sup>1</sup>, Cameron Johnstone<sup>1</sup>, Jaemin Kim<sup>1</sup>, Georgios Kokogiannakis<sup>1</sup>, Paul Tuohy<sup>1</sup>, Kyung-hun Woo<sup>2</sup>

<sup>1</sup>ESRU (Energy Systems Research Unit), Dept. of Mechanical Engineering, University of Strathclyde, Glasgow, UK

<sup>2</sup> Samsung C&T Corporation, Republic of Korea

### ABSTRACT

Currently, there is a high emphasis on reducing the energy consumption and carbon emissions of buildings worldwide. Korea is facing an emerging issue of energy savings in buildings in perspective of new green economic policy. In this context, various policy measures including the energy efficiency ratings for buildings are being implemented for domestic and non-domestic buildings. In practice, design teams tend to prefer easy to use assessment tools to optimise energy performance and carbon ratings while they are concerned about calculation accuracy and the accurate representation of the dynamics involved associated with the characteristics of Korean residential buildings. This paper presents an assessment tool, named 'EDEM-Samsung' that aims to address these challenges for Korean residential apartments, which often encounter complex design issues. EDEM-Samsung is a tool that enables users to make rapid decisions identifying the effect of design parameter changes on energy and carbon ratings with an effective user interface and without compromising accuracy. This paper describes the architecture and functionalities of the tool, and the advantages offered to Korean designers.

### INTRODUCTION

New regulations and policy measures are being implemented in Korea to promote energy and carbon savings in buildings from the perspective of environmental protection. The assessment methodology of energy performance of domestic buildings was developed on the basis of a simplified method (Park et al, 2008). There are, however, difficulties in practice for design teams to assess the energy performance of Korean residential apartments in particular for the balcony areas (sunspaces) where the dynamics affecting solar gains and transmission losses have to be quantified.

The rapidly growing need for energy and carbon assessments and the need to account in this for the complexity of Korean residential building designs has brought practitioners in a difficult position where detailed energy performance assessments may be more appropriate for use than traditional simplified approaches (for example, steady-state methods that use fixed U-values). On the other hand, design teams

and in particular architects in Korea are unfamiliar with detailed simulation programs with which they require substantial effort and time to perform their assessments. To address these, the development of a software tool was required that is based on simplicity, covers the characteristics of the Korean residential apartments and does not compromise building physics during the calculations. This paper presents the architecture and functionalities of the tool, and the advantages offering to the Korean design teams.

### ISSUES IN ASSESSING ENERGY PERFORMANCE OF KOREAN RESIDENTIAL APARTMENTS

Korean residential apartments, as seen in Figure 1, typically have balcony areas. Windows are installed internally separating the living area from the balcony; and externally separating the balcony from the outside. The balcony areas are not thermally conditioned, but function as a buffer zone to mitigate heating/cooling loads and environmental impacts such as external noise.



*Figure 1 Typical Korean Apartment*

Depending on the dimensions of the balcony areas and the modelling approach adopted, the calculated solar radiation entering the living areas through the windows of the balconies are different. A number of researchers have studied the effects of different balcony configuration in terms of energy performance (Lee et al 2007, Park et al 2006, Kim et al 2007).

Their different modelling approaches for the balconies (as a separate zone, as part of the construction with fixed air gap resistance, etc.) lead to different conclusions for the effect of the balcony spaces on the energy performance of Korean buildings. Kim et al (2008) pointed that a detailed solar distribution analysis needs to be adopted to assess the energy performance of Korean apartments with glazed balconies since the design elements affecting the solar radiation entering the building (e.g. balcony depth, window-to-wall ratio, glazing optical properties, etc.) have a significant impact on the heating loads. For example, they found that the depth of balconies has a different effect on the heating loads for South balcony orientations than for North orientations, i.e. decreasing the depth of South balconies leads to a decreased annual heating load (with about 18 % to 39% reduction rate), while the opposite happens for North oriented balconies, which is the same results obtained from the simplified methods.

It is required to evaluate the energy performance of this type of designs by taking account of the thermal and optical properties of the glazing system; and at the same time, the geometric characteristics that would affect the solar distribution analysis on the inside building surfaces. As the simplified methods can hardly take account of these detailed design parameters, the results of energy performance assessment could lead to inappropriate strategies. This was the main reason that made necessary the use of dynamic simulation for studying the energy performance of this type of apartments.

### ARCHITECTURE OF EDEM-SAMSUNG

EDEM-Samsung is a building performance assessment tool and is a further development of the ESRU Domestic Energy Model (EDEM) (Clarke et al 2008). In addition to the basic functions inherited from EDEM (which is based on a database of results from prior simulation of an array of models representing the entire building stock), EDEM-Samsung is additionally equipped with the dynamic building simulation engine. This allows calculations to be run real time for models adjusted by the user rather than relying on the results from the standard models as pre-defined in the tool. The advantage of this approach is to enable users to make rapid design changes and get more specific energy performance focusing on actual rather than discretised construction configurations (i.e. walls, windows, geometric etc.).

A pre-defined array of design templates for various dwelling types and a range balcony configurations is provided in the tool. The EDEM-Samsung tool generates a meta file (refer to the following section) for the ESP-r dynamic simulation engine based on the selected template, modified as required by the user. This file consists of the appropriate design parameters to describe the ESP-r model. The meta

file (i.e. compact model input file.) is different from the traditional input files for ESP-r. ESP-r's Project Manager functionality has been extended to translate the information from this meta file to a complete set of the traditional input files for ESP-r simulation. This allows ESP-r simulations to be automatically run based on the contents of the meta file. After the simulation process is completed, the energy performance results are passed back to the EDEM-Samsung tool, used in further calculations and the selected results made available through the tools user interface. A benefit of this approach is that it enables the user, through the simple EDEM-Samsung interface, to write input files for ESP-r and execute detailed simulations without the overheads required to use the simulation tool directly. The simulation procedure itself and all but the user modifiable input parameters are fixed at standard values and remain hidden from the user, providing a solid platform for the simulation and reducing the opportunities for potential mistakes. The results are then displayed automatically after the simulation is finished.

This tool focuses on the need to prevent non-expert users from the complexity of dynamic simulation engines. The users can pick a template, apply any allowed design changes, save their customised model and then initiate a simulation. EDEM-Samsung provides the best of both worlds by combining the simplicity the user is looking for in the form of an easy to use interface and the accuracy of results from the power of dynamic simulation.

Its purpose here has been limited to the Korean residential housing stock with the building models and other simulation parameters selected to represent the Korean building stock.

The tool offers the facility to save projects and their results in a database and re-visit them at a later stage. EDEM-Samsung provides a graphical energy rating output to allow practitioners unfamiliar with performance calculations to obtain understanding of the effects of design parameters. Figure 2 summarises the architecture of the EDEM-Samsung software.

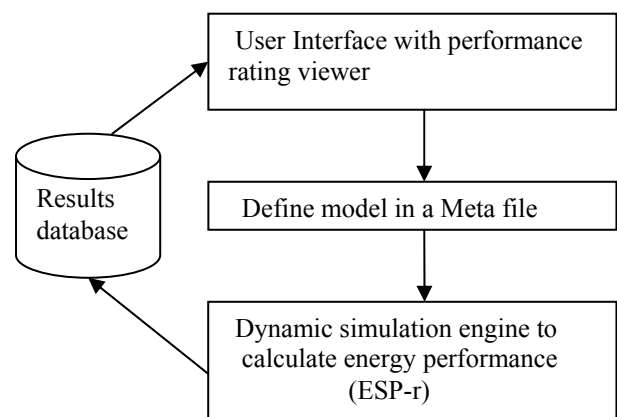

Figure 2 Architecture of EDEM-SAMSUNG

## META FILE: INTERCONNECTIVITY OF EDEM-SAMSUNG

After selecting a building model, and applying any required modifications, EDEM-Samsung must communicate the attributes of the building to the simulation engine. There are many possible routes to transform into the native file structure which a general purpose simulation engine requires.

ESP-r has traditionally relied on a partitioned description of a model composed of several folders and scores of files. Its descriptive language can be used to describe buildings and systems of arbitrary complexity and support simultaneous solution of multiple analysis domains but EDEM requires only a fraction of this information.

The development team did not want to burden third-party tools the necessity to create and manage the fully partitioned description, especially as ESP-r is rapidly evolving. For example, ESP-r is used as an engine by Natural Resources Canada (NRC) for a web based energy advice tool. NRC took the route of generating the partitioned files and the resource required for this was considerable. It has also locked the ESP-r community into a set of legacy file formats. In more recent projects the idea evolved to explore whether a limited set of high level attributes could be used in place of a literal/verbose representation.

The communication between EDEM-Samsung and the ESP-r simulation engine needed to be implemented and tested in stages, it needed to conform to the GNU license used by ESP-r and it needed to be done within a limited development budget. The team considered gbXML. There are a number of useful features in this API but the API is massive and beyond the resources available to the ESP-r community. Other mature standards, such as STEP, which ESRU had worked with in the past, are also beyond the scope of a small development team with a tight time line. What the team did have was a substantial library of functions for parsing tag-data files, functions for transforming building model entities and a complete knowledge about the ESP-r data model and the EDEM-Samsung data models.

The approach taken was to design a meta file composed of tag-data entries representing a sub-set of the simulation data model and concentrate efforts on the object attributes and the transformations to be applied. We created wrappers around existing code blocks or made existing code modular to accomplish the required task. For example, code to add a window into a wall and reconcile the dozens of dependencies within the simulation data model already existed. What was required was to define a tag and a minimal set of attributes for the meta file and then use this to drive the newly modularized code. The meta file is thus a rapid prototyping language. Once the full

extent of the facility is defined and the back-end functionality is in place, it should be possible to recast the syntax used in the meta file into gbXML if resources become available.

The meta file tokens are similar to those found in other neutral formats, but the decoration is different. For example to create a three zone model (Figure 3) with an extruded floor plan pavilion with an inserted door and window, a roof space created from polygons and the room below derived from a box shape with a window and door added requires a meta file of 80 lines. The resulting ESP-r model requires 15 files and a total of 450 lines.

The meta file is composed from a dictionary of tokens. One section of this file includes information for the site (latitude, longitude, etc.) and an existing weather file to be used during assessment. If greater specificity is required then additional tokens can be included – such as monthly temperatures. The meta file also includes directives about the assessment to be carried out: time steps per hour, period of simulation, etc.

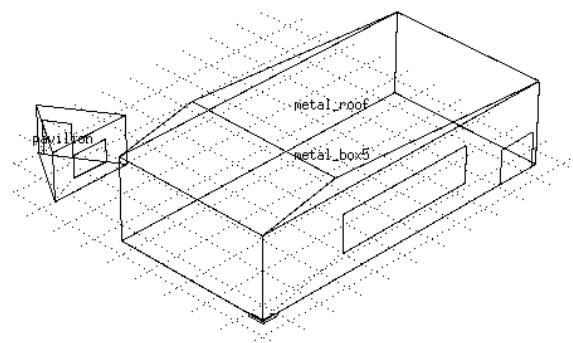

*Figure 3. ESP-r model created through a meta file.*

The meta file then includes sections for each thermal zone of the building. This is the place where coordinates of surfaces, boundary conditions and constructions are specified. Information about systems, temperature and humidity setpoints are also specified here. The fragment below defines the composition of the pavilion zone, where *\*shape*, *\*nbwalls*, *\*cord*, *\*rotate*, *\*surface* are tags with attributes. For example the *\*surface* line is followed by five tokens defining the name of the surface, what is composed of and three integers describing the boundary conditions.

```
*start_zone,pavilion
*shape,extrude
*nbwalls,3
*cord,0,0,15.0
*cord,5,0,15.0
*cord,2,5,19.0
```

```

*origin,0.0,3.0,0.0 # base Z and top Z and ignored
*rotate,0.0 # rotation
*glaze,1,1,20.0 # how many, index of parent and percent
*door,1,2,1.5 # how many, index of parent and width of door
*surface,front,extern_wall,0,0,0
*surface,right,extern_wall,0,0,0
*surface,left,extern_wall,0,0,0
*surface,roof,roof_1,0,0,0
*surface,floor,floor_1,4,1,0
*surface,door,door,0,0,0
*surface,glaz_front,dbl_glz,0,0,0
...

```

With careful documentation of the syntax expected and the specific meaning of the tokens and attributes several third party developers have been able to generate the meta file. Conceptually, the tokens for an extruded or box shaped zone allow for high level tokens to be used. There is also a poly shaped zone where all coordinates are explicitly passed. It is up to the third party application whether they want to use the higher level or more detailed tokens.

All the technicalities of simulation procedure and how it is invoked are hidden to avoid complexity for the user who only views the results automatically after the simulation is finished. The originating application can generate meta files which are rough approximations of an early design idea or a more extensive set of details as the design progresses.

## BASIC MODEL TEMPLATES

EDEM-Samsung has built-in design templates provided in the tool to incorporate Korean residential apartment types. The development of these templates was based on a large number of drawings that were provided to the authors by design teams within the Samsung C&T organisation. The templates have been designed to accommodate a number of balcony configurations (balconies are modelled as separate thermal zones), since this is a basic characteristic of Korean residential buildings. The design templates include configurations of apartments ranging from apartment with only one balcony, balconies aside, balconies opposite to each other to balconies and internal walls. Since a wide range of possible options are provided, EDEM-Samsung does not require to build a model from scratch. Design teams can build new models by making relevant changes to the existing templates. The process of customising a template is efficient and straightforward for the design teams to follow. Figure 5 shows some basic model templates.

## DESIGN PARAMETERS

Predominant design parameters were identified and are possible to be changed within the design templates in order to optimise the carbon and energy performance of an apartment. The default values for these parameters were identified from the majority of the building details that were provided to the authors.

This section describes the main design parameters that are available as a user choice through the interface of EDEM-Samsung (an example is also given in Figure 7).

### *Geometry*

Building regulations in Korea have been recently updated to allow flexible building designs in terms of new configurations for previously compulsory balcony areas in both new and existing apartments. These new regulations have encouraged the house owners and construction companies to increase flexibility of space utilization by preferring designs which maximize living space and minimize balcony areas.

To incorporate this flexibility, EDEM-Samsung allows changes in building geometry by altering the width and depth of the room type as selected from the appropriate template.

### *Envelope properties*

Roof, floor and wall properties can be modified by making selection from a number of thermal transmittance (U-value) options. The tool provides an extensive list of options to choose for wall, roof and floor constructions. For wall constructions the U-values range from 2.00 to 0.1. The roof U-values covers an extensive range from 0.28 to 0.5. Floor constructions can be selected using U-values from 0.43 to 0.5. All U-values are based on information gathered from Korean regulations.

It is also possible with the tool to examine the effect of the thermal inertia on the results. A number of different wall options are included in the database with insulation layers placed at different positions (e.g. near the outside wall layer or the near the inside building environment). The database of the tool is also extended to the rest of the envelope items (e.g. floors, ceilings) in order to allow the study of buildings with different thermal mass (heavyweight, lightweight, plus intermediate options).

### *Orientation*

To inspect the effect that orientation might have on the thermal performance and heating load of the apartment, EDEM-Samsung offers the option of eight basic orientations to be used in the design phase which are: south, south-east, east, north-east, north, north-west, west and south-west. The simulation engine will initiate solar distribution (insolation) analysis each time the orientation is changed.

Building regulations in Korea consider only these basic orientations for heat loss and solar gains calculations and the approach taken in EDEM\_Samsung was considered adequate to cover these specifications. EDEM-Samsung is a simulation-based tool and if required by design teams it will be straightforward to include in the next version of the tool the option to define the precise azimuth angle for the building's orientation.

However, the available options for the building orientation were preferred in order to maintain the simplicity that is provided to the users.

*Position*

The apartment can be defined at top, middle or ground level. This will define the boundary conditions of the roof and floor envelope elements. Monthly ground floor temperatures based on measured ground temperatures are used for the ground floor boundary condition.

*Balcony size*

Balcony depth in a typical Korean apartment is usually around 1.4m. However, refurbishments are being encouraged by the new building regulations to reduce the balcony area and expand the living area of the apartment. Therefore, along with the standard balcony depth of 1.4m, EDEM-Samsung also provides the user with the options of 0.7m and 0.1m for balcony depth to see the effect of reduced balcony areas on thermal performance. A few buildings have had balconies with a depth of approximately 2.1m and this has been also considered in the design options of the interface. Another important factor to consider is that balcony depth has different effect on the heating loads for various balcony orientations. This can be analysed by selecting a combination of different orientations in the tool. Balconies are considered in the tool as separate preconfigured thermal zones.

*Glazing properties*

EDEM-Samsung offers options for selecting basic glazing configurations to analyze their impact on the building's energy performance. It was important to include U-values as well as optical properties in the glazing systems of EDEM-Samsung (they are given in Table 1 and Figure 4). Studies have shown that the cases where balcony has been removed, using clear double glazing leads to better energy performance than the triple low-emissivity glazings for south orientations in Korea although, the U-values of triple glazing windows are lower (Kim J *et al.*, 2008). The reason being that the triple glazing windows have lower solar transmittance values and limit the solar gains entering the room. The use of the ESP-r dynamic simulation within EDEM-Samsung helps to achieve a balance between the optical properties of glazing and its thermal characteristics. Simulation is also beneficial here since the balcony spaces are modelled as separate thermal zones.

**PERFORMANCE RATING VIEWER**

A specific results output file from ESP-r was developed to be used for the EDEM-Samsung tool. The results for the heating and cooling loads are read by the EDEM-Samsung interface and displayed in the feedback area. After heating demand has been

calculated using the ESP-r simulation engine, various levels of parameters for ventilation, hot water, lighting system, appliance energy use can be applied to the model through the main interface which inherited from EDEM (Clarke\_ *et al.*, 2008). System type, fuel type and controls are used to set space heating efficiency values.

double clear	double low-e	triple low-e
3.3	2.7	2.4
3.1	2.5	2.1
2.8	2.2	1.8
2.5	2.0	1.5
2.2	1.5	1.2
	1.3	1.0
		0.8

Table 1 U-values (W/m<sup>2</sup>K) for different glazing types provided in EDEM-SAMSUNG

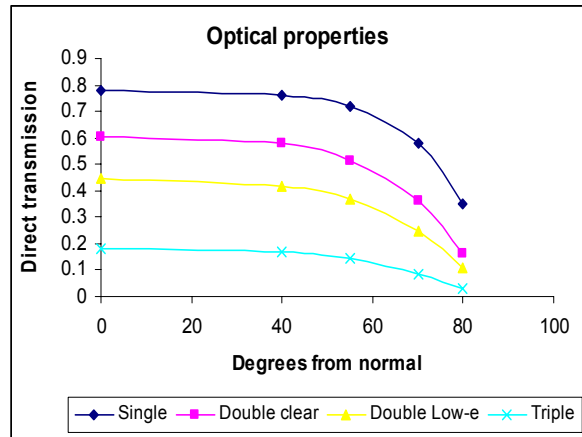

Figure 4 Solar transmittance for glazing provided in EDEM-Samsung

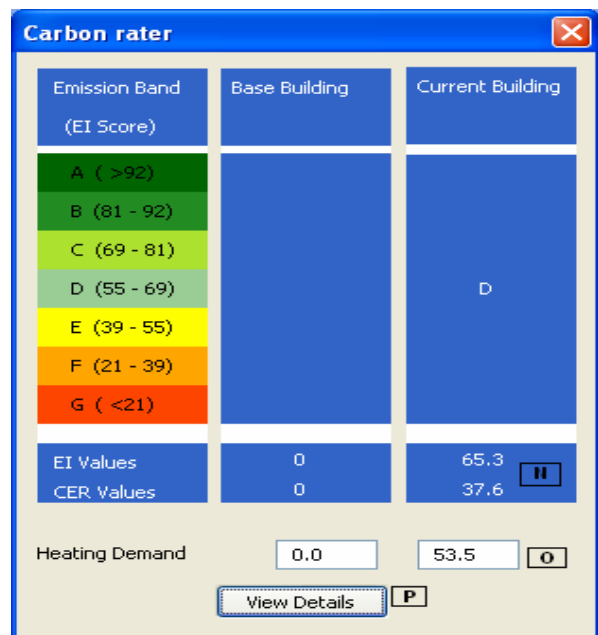

Figure 6 Display of Carbon Emission Rating of a model

Figure 6 shows the carbon rater, which displays the Environmental Impact (EI) values as values of CO<sub>2</sub> emissions normalised in a scale of 0-100. It also displays a carbon emissions rating (CER), which is an absolute value of CO<sub>2</sub> emissions (kg CO<sub>2</sub>/m<sup>2</sup> per annum). Heating demand as calculated by ESP-r is also displayed (annotated as “O” in Figure 6).

### APPLICATION IN PRACTICE

EDEM-Samsung is currently used within a construction company, “Samsung Construction & Technology” in Korea. The design teams of the company are involved with residential apartments, in particular in the construction of high-rise buildings. Designers and engineers within the company can use this program in development stage of residential projects without any knowledge of energy simulation. These members are using the program as a simplified assessment tool in order to optimise the initial design and prior to the application of a detailed energy simulation by more specialised members of the company. EDEM-Samsung can speed up the engineering working time during the design process. However, since the tool is based on the dynamic simulation, the results of the tool in some cases can be different from those of the Korean residential building energy performance rating tool. To make the tool compatible with the Korean official energy performance rating tool, it is still required to calibrate the results. The comparison analysis between EDEM-Samsung and the Korean official tool is to be implemented in due course. The extension of the results to include cooling load and summer overheating analysis is also underway.

### CONCLUSION

EDEM-Samsung is a tool with a simplified user interface which can be used to investigate the thermal performance of Korean residential apartments. A number of design options can be evaluated to investigate their impact on the energy and Carbon reduction rating. Due to the simplicity and ease of use, no training is required by the design teams in order to use this tool. The tool provides results calculated by the ESP-r simulation engine for each case which offer better accuracy and reliability as compared to steady state calculations. This is particular important because of the nature of Korean residential buildings that have as main characteristic difficult to model balcony spaces.

The benefits from this tool are significant for the design teams within a construction company of which members not familiar with detailed simulation have the ability to identify appropriate design strategies at the early design stages of buildings. This is before the application of in depth simulation that is usually applied at later design stages and by specialised members of the construction team.

### REFERENCES

- Clarke J A, Ghauri S, Johnstone C, Kim J, Tuohy P G. 2008, The EDEM Methodology for Housing Upgrade Analysis, Carbon and Energy Labeling and National Policy Development, . Proc. eSim, Quebec, Canada.
- Kim J, Clarke J, Johnstone C, Kokogiannakis G, Strachan P, Woo K and Kang B. 2008, Study of the Energy Performance of Korean Apartment Buildings with Alternative Balcony Configurations. Proc. World Renewable Energy Congress (WRECX), Glasgow, UK.
- Kim S., Park S., Lim J., Kim B. 2007, Economic Study on Heating Load by Balcony Remodelling in Use of Energy Simulation Program, Proceedings of the SAREK Annual Conference, pp 801-806
- Kokogiannakis G., Strachan P., Clarke J. 2008, Comparison of the simplified methods of the ISO 13790 standard and detailed modelling programs in a regulatory context, Journal of Building Performance Simulation,1:4,209 — 219
- Lee J., Yu K., Cho D., Suh S. 2007, Analysis of Heating Load Regarding Balcony Remodelling in Apartment, Proceedings of the SAREK Annual Conference, pp 845-850
- Park H., Hong S., Kim J., Suh S. 2006, the Effect of Building Energy Rating on the Balcony Remodelling in Apartment, the Journal of AIK, Vol 22 no 3.
- Park H., Kim J., Kim J. 2008, Enforcement of the Energy Rating System for Building Structures in Korea, Proc. World Renewable Energy Congress (WRECX), Glasgow, UK.



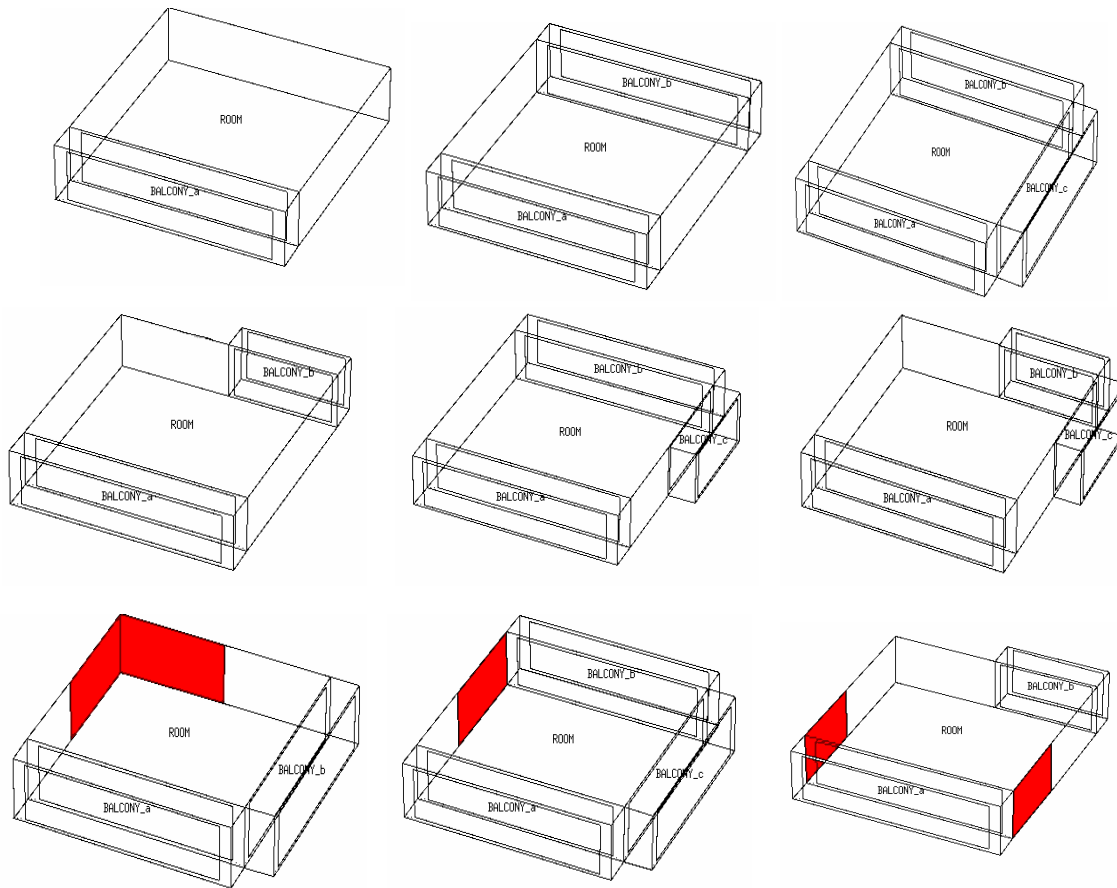

Figure 5 Examples of design templates for EDEM-Samsung tool

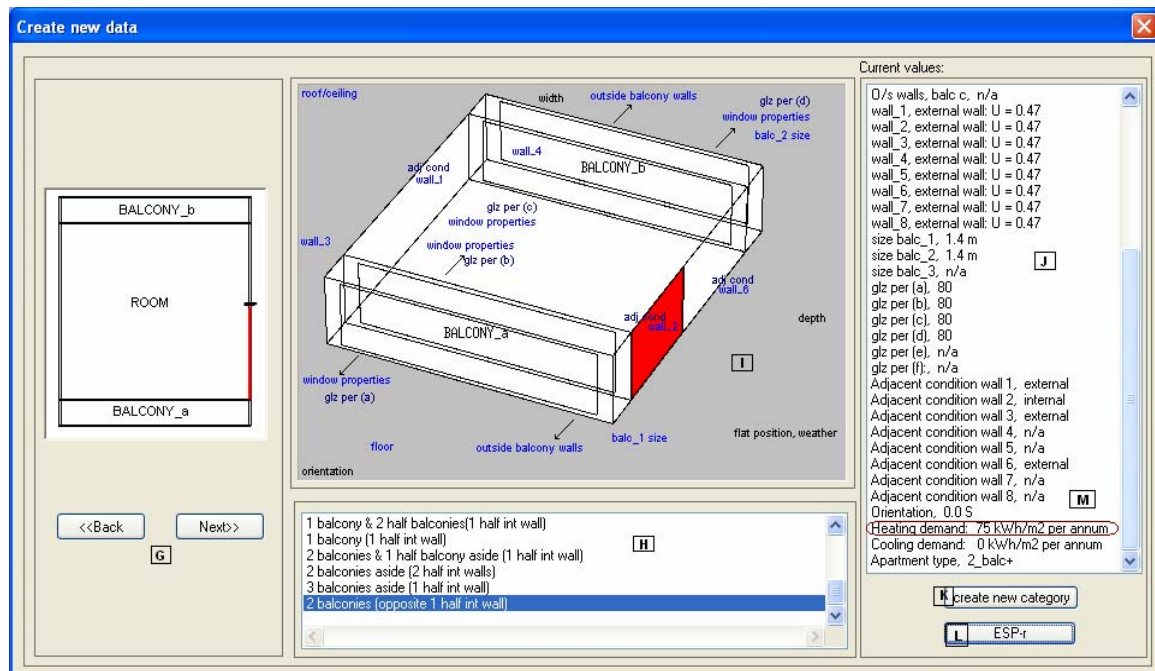

Figure 7 EDEM-Samsung tool interface to apply design changes