



UNIVERSITY  
OF WOLLONGONG  
AUSTRALIA

University of Wollongong  
Research Online

---

Faculty of Engineering and Information Sciences -  
Papers: Part A

Faculty of Engineering and Information Sciences

---

2014

# The development of an adaptive tuned magnetorheological elastomer absorber working in squeeze mode

Shuaishuai Sun

*University of Wollongong, ss886@uowmail.edu.au*

Ying Chen

*University of Wollongong, yingchen@uow.edu.au*

Jian Yang

*University of Wollongong, jy937@uowmail.edu.au*

Tongfei Tian

*University of Wollongong, tt436@uowmail.edu.au*

Huaxia Deng

*Hefei University of Technology*

*See next page for additional authors*

---

## Publication Details

Sun, S. S., Chen, Y., Yang, J., Tian, T. F., Deng, H. X., Li, W. H., Du, H. & Alici, G. (2014). The development of an adaptive tuned magnetorheological elastomer absorber working in squeeze mode. *Smart Materials and Structures*, 23 (7), 1-8.

Research Online is the open access institutional repository for the University of Wollongong. For further information contact the UOW Library: [research-pubs@uow.edu.au](mailto:research-pubs@uow.edu.au)

---

# The development of an adaptive tuned magnetorheological elastomer absorber working in squeeze mode

## **Abstract**

In the past, adaptive tuned vibration absorbers (ATVAs) based on magnetorheological elastomers (MREs) have mainly been developed in a shear working mode. The enhancing effect of MREs in squeeze mode has already been investigated, but ATVAs in squeeze mode have rarely been studied. This paper reports the development of a compact squeeze MRE absorber and its subsequent performance in various magnetic fields characterized under various frequencies by a vibration testing system. The results revealed that the natural frequency of the MRE absorber working in squeeze mode can be tuned from 37 Hz to 67 Hz. Following this, a theoretical model based on magnetic dipole theory was developed to investigate the dynamic performance of the squeeze MRE absorber, and the vibration attenuation of the squeeze MRE absorber was then verified by mounting it on a beam with supports under both ends. The results revealed that the squeeze MRE absorber extended its vibration attenuation range from 37 Hz to 67 Hz while the passive absorber was only effective around 53 Hz.

## **Disciplines**

Engineering | Science and Technology Studies

## **Publication Details**

Sun, S. S., Chen, Y., Yang, J., Tian, T. F., Deng, H. X., Li, W. H., Du, H. & Alici, G. (2014). The development of an adaptive tuned magnetorheological elastomer absorber working in squeeze mode. *Smart Materials and Structures*, 23 (7), 1-8.

## **Authors**

Shuaishuai Sun, Ying Chen, Jian Yang, Tongfei Tian, Huaxia Deng, Weihua Li, Haiping Du, and Gursel Alici

# **The Development of an Adaptive Tuned Magnetorheological Elastomer Absorber Working in Squeeze Mode**

S. S. Sun<sup>1</sup>, Y. Chen<sup>1</sup>, J. Yang<sup>1</sup>, T.F. Tian<sup>1</sup>, H.X. Deng<sup>\*2</sup>, W.H. Li<sup>\*1</sup>, H. Du<sup>3</sup>, and G. Alici<sup>1</sup>

<sup>1</sup>*School of Mechanical, Material and Mechatronic Engineering, University of Wollongong, New South Wales, 2522, Australia*

<sup>2</sup>*School of Instrument Science and Opto-electronics Engineering, Hefei University of Technology, Hefei, China*

<sup>3</sup>*School of Electrical, Computer and Telecommunications Engineering, University of Wollongong, New South Wales, Australia*

\*Corresponding author emails: [hxdeng@hfut.edu.cn](mailto:hxdeng@hfut.edu.cn); [weihuali@uow.edu.au](mailto:weihuali@uow.edu.au)

## **Abstract:**

Adaptive tuned vibration absorbers (ATVA) based on magnetorheological elastomers were mainly developed in a shear working mode. The enhancing effect of MRE in squeeze mode has already been investigated but an ATVA in squeeze working mode has rarely been studied. This paper reports on the development of a compact squeeze MRE absorber and its subsequent performance in various magnetic fields characterised under various frequencies by a vibration testing system. The results revealed that the natural frequency of the MRE absorber working in squeeze mode can be tuned from 37 to 67 Hz. Following this, a theoretical model based on magnetic dipole theory is presented to investigate the dynamic performance of the squeeze MRE absorber, and then the vibration attenuation of the squeeze MRE absorber was verified by mounting it to a beam with supports under each end. The results revealed that the squeeze MRE absorber extended its vibration attenuation range from 37Hz to 67Hz while the passive absorber was only effective around 53Hz.

## **Keywords:**

Adaptive tuned dynamic vibration absorber (ATVA), Magnetorheological elastomers, Squeeze working mode, vibration attenuation

## 1. Introduction

Dynamic vibration absorber (DVA), invented by Frahm in 1911 [1], is an auxiliary mass spring system that is used to suppress vibration in a structure, and it generally consists of an oscillator, a stiffness component, and a damping component. The basic principle of operation is transferring the energy of the objects to the oscillator in the absorber. Because a dynamic vibration absorber has the advantages of simplicity, stability, high reduction of vibration, low cost and low power consumption, they are widely used to control vibration in building structures, the automotive industry, aircraft, generators, earthquake resistance, and engines [2, 3].

DVAs mainly contain three different types which are passive DVA, active DVA and semi-active DVA. The passive DVA, which consists of mass, spring and a damper, has the advantages of simple structure and stability. However, it normally only works around the natural frequency which limits their working range and means they cannot deal with changeable frequency or multiple frequencies. To overcome these shortcomings, active and semi-active controlled dynamic vibration absorbers have been studied extensively. Active dynamic vibration absorber that consists of an oscillator, stiffness component, damping component, and an active force generator and controller, is one kind of device that uses active force to attenuate vibration. Davis et al. [4, 5] applied a piezoceramic inertial actuator (PIA) to an adaptively tuned dynamic vibration absorber (ATVA), and this allowed them to vary its natural frequency from 243 to 257 Hz. Apart from the piezoelectric actuators, the electromagnetic motors, electrical linear motors and pneumatic springs are also used to develop the active absorber[6, 7]. However, an active control system normally needs large control forces and a large power source, especially when the working frequency is far from its natural frequency. Furthermore, an active dynamic vibration absorber also increases the complexity of the system and decreases its stability, factors that limit its practical applications[8]. The semi-active DVA is composed by a changeable coefficient, albeit its composition is similar to a conventional dynamic absorber apart from having a variable coefficient element. Semi-active dynamic absorbers are generally divided into two major groups: a mechanical tuning dynamic vibration absorber and a smart material tuning dynamic vibration absorber. In terms of the mechanical tuning dynamic vibration absorber, Nagaya et al. proposed and designed a tunable vibration absorber based on a cantilever beam[9], Walsh and Lamancusa reported on a new tunable absorber having adjustable vanes[10], and Xu et al. developed a

mechanical adaptive tuned vibration absorber by varying the distance between the two springs[11]. On the other hand, magnetorheological (MR) and electrorheological (ER) materials, shape memory alloys, and piezoelectric materials are mainly used to develop smart material based absorbers [12-14].

Magnetorheological elastomer (MRE), as a member of the MR materials family[15], generally consists of micro-sized magnetic particles dispersed in a non-magnetic matrix. MRE is a smart material that can vary its stiffness, respond quickly, has a simple structure, and is very stable, and it can be controlled, attributes that make MRE the ideal smart material from which to develop vibration attenuation devices, especially an adaptive tunable vibration absorber [16-21]. The shear working mode MRE absorber has already been investigated by a number of researchers. Ginder and coworkers did pioneering work on the development of an adaptive tunable vibration absorber based on MRE[16]. Deng et al. applied MRE to absorbers and also presented a series of MRE absorbers working in shear mode[22]. Their results indicated that the frequency of a vibration absorber can be tuned from 55 to 82 Hz. Deng and Gong then developed a compact and efficient shear working mode MRE absorber where all the components were a part of the dynamic mass[23]. The same group then extended their research by using an active force to develop active-adaptive vibration absorbers to further suppress vibration [24, 25]. Hoang and coworkers presented a conceptual ATVA with soft MREs to reduce the vibration inherent in vehicle power train systems[26, 27]. Their numerical results showed that an ATVA with MRE material can effectively work in a frequency ranging from around 7 to 70 Hz. The above research focused on the shear working mode of an MRE absorber while research on the MRE working in squeeze mode presented in existing literature is limited. Popp et al. analysed the MR effect under shear and squeeze modes based on experimental studies and simulations[28]. In their work two structures that can be considered as concept MRE absorber working in shear and squeeze mode were tested, and the results showed that the squeeze working mode MRE absorber had a larger frequency shift range than the shear MRE absorber. Thus, the squeeze working mode MRE is a good choice to extend the frequency shift range of MRE absorber. Lerner et al developed a conceptual squeeze ATVAs by using MRE in squeeze mode[29]. However, the structure of the absorber is not stable especially when there is no current is applied, which limits its practical application. Also, the coil and the magnetic conductor cannot function as dynamic mass to absorb vibration, which decreases its absorption effectiveness. Therefore, the development of a

compact, stable and more effective squeeze MRE absorber which has a larger frequency shift range than shear MRE absorber is crucial. Also, theoretical analysis of the squeeze MRE absorbers to reveal the working mechanisms is also inadequate. This was the major motivation for this research into investigating a compact MRE absorber working in squeeze mode through experimental and theoretical research.

The paper is organised as follows: First, MRE material was fabricated and characterised and then a compact squeeze MRE absorber was developed, after which a vibration test system was applied to test its frequency-shift properties. A theoretical model was developed to predict the performance of an MRE absorber working in squeeze mode. Finally, the vibration attenuation performance of the MRE squeeze absorber was evaluated using a beam that was supported at both ends.

## **2. Development of squeeze working mode MRE absorber.**

The conceptual structure of an MRE absorber working in squeeze mode was designed and then MRE material was prepared and tested for this conceptual MRE absorber. After this a squeeze working mode MRE absorber was developed based on the fabricated MRE.

### **2.1 Conceptual design.**

In this part the conceptual design of a compact MRE absorber working in squeeze mode was carried out. The structure of the squeeze MRE absorbers is shown in Fig.1 where the four main parts are the oscillator, the smart spring element with MREs, the magnetic conductor, and the coil. Compared to the concept MRE absorber working in squeeze mode in Popp's paper[28], this squeeze MRE absorber used four guide rods to keep it stable, the coil and magnetic conductor form part of the oscillator, which makes it more efficient and more compact because most components function as a dynamic mass. The working principle of this MRE is as follows; the magnetic fields generated by the coil can be controlled by the current from an external DC power, its squeeze modulus is determined by the strength of the magnetic field, its modulus determines the stiffness of the ATVA such that any change in the MRE's stiffness will vary the natural frequency of the ATVA. As a consequence the natural frequency of the ATVA can be controlled by tuning the current in the coil such that when the natural frequency of the ATVA matches the excitation frequency, the vibration can be suppressed quite significantly.

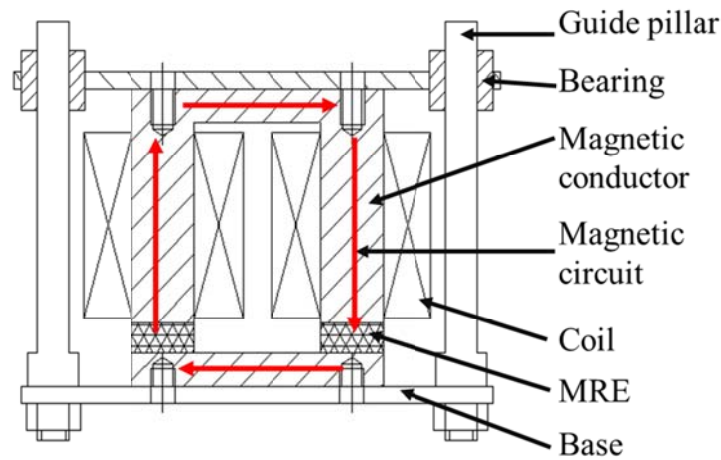

Fig.1 A schematic of a compact squeeze MRE absorber

## 2.2 Prototyping the squeeze working mode of an MRE absorber

In this part, MRE material with mass fraction ratios of 7.5:1.25:1.25 of iron, silicon oil, and silicone rubber was first prepared and tested, and then the squeeze working mode MRE absorber was developed based on the fabricated MRE. The process of MRE fabrication is as follows: iron particles were placed into a container and then silicon oil was poured in and then the materials were mixed thoroughly. The mixture was placed inside a vacuum case to remove the air bubbles and then it was poured into a mould and cured for 24 hours at room temperature. From this mixture a sample of MRE with iron particles having a mass fraction of 75% was fabricated.

A device was then designed to test the MR effect of the prepared MRE. As Fig.2 shows, two coils were used to excite different magnetic strengths by changing their currents. This device was clamped inside an MTS test system. The MTS machine is operated by a servo hydraulic system that can induce harmonic excitation onto the test specimen. The axial force generated by the harmonic excitation was then observed through the load cells, after which the displacement and force signals were saved to a computer via a data acquisition (DAQ) board. Thus, the relationship between the displacement and force of the MRE sample under different magnetic strengths could be obtained and then the effect that the magnetic strength had on the modulus of MRE sample could be calculated. The relationship between the magnetic strength and the increased magnetic compressive modulus  $\Delta E$  is shown in Fig. 3. This figure indicates that the

magnetic strength increased from 0 to  $9.5 \times 10^4$  A/m, which enhanced the compressive modulus of the MRE by  $1.37 \times 10^5$  Pa.

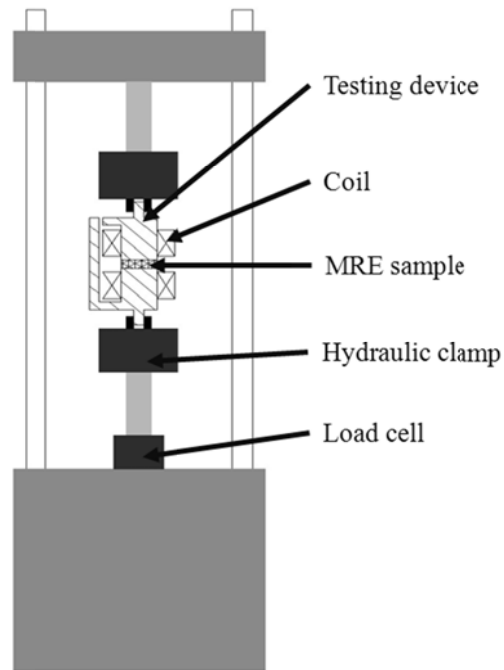

Fig. 2 MTS test system for MRE sample

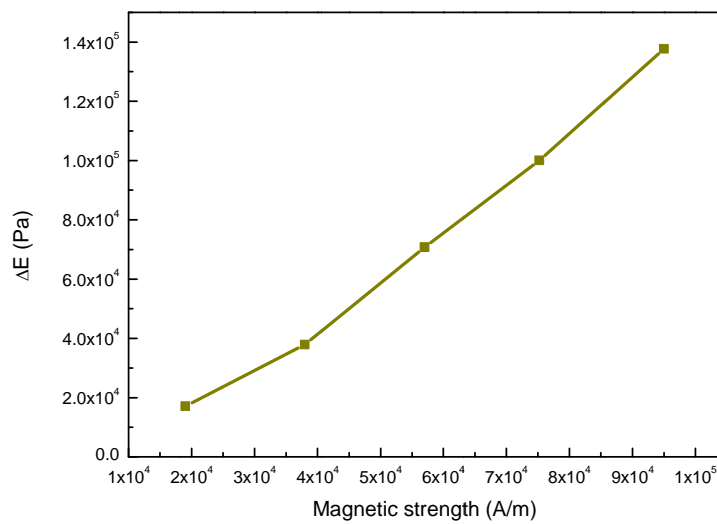



Fig. 3 The relationship between the magnetic strength and increased magnetic squeeze modulus

Based on the prepared MRE, the squeeze working mode MRE absorber was prototyped as shown in Fig.4. Similar to the conceptual design of squeeze working mode MRE absorber, the prototyped squeeze MRE absorber was composed by oscillator, the smart spring element with MREs, the magnetic conductor, and the coil. The four guide rod was connected to absorber base. The four linear bearing mounted on the four guide rods was connected to the oscillator. The two coils and magnetic conductor composed the oscillator and generate a magnetic circuit inside the oscillator. The working characteristic of this absorber is as following. During the process that the vibration transferred to absorber, four rods were used to lead the oscillator to vibrate in vertical direction in order to keep the absorber works stable. The coil and magnetic conductor functioning as part of the oscillator enhanced dynamic mass to further improve absorption effectiveness.

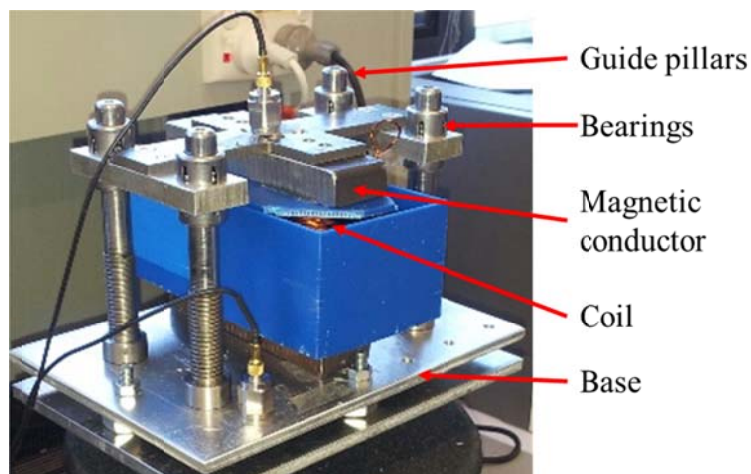

Fig.4 The structure of the squeeze MRE absorber

### 3. Experimental study of the frequency-shift properties of a squeeze MRE absorber

#### 3.1 Absorber's transmissibility

When the squeeze working mode absorber, which may be considered to be a single-degree-of-freedom (SDOF) vibration system, was mounted to a shaker the system can be considered to be an SDOF system with foundation vibration stimulation. Thus the transmissibility presented in [30] was also adapted to the squeeze working mode MRE absorber. The magnitude and phase

transmissibility of the squeeze working mode MRE absorber are:

$$T = \sqrt{\frac{1+(2\zeta\lambda)^2}{(1-\lambda^2)^2+(2\zeta\lambda)^2}} \quad (1)$$

$$\varphi = \tan^{-1} \frac{-2\zeta\lambda^3}{1-\lambda^2+(2\zeta\lambda)^2} \quad (2)$$

where  $\omega_0 = \sqrt{\frac{k}{m}}$ ,  $\lambda = \frac{\omega}{\omega_0}$ ,  $\zeta = \frac{c}{2m\omega_0}$ .  $\omega$  is the vibration frequency.  $m$  is the mass of absorber,  $k$  is the stiffness of the spring, and  $c$  is the damping coefficient. When the magnitude transmissibility  $T$  reached its maximum value and the phase delay between the oscillator and the base was  $-\pi/2$ , the corresponding exciting frequency was the resonance frequency.

### 3.2 Test of the squeeze working mode MRE absorber

Fig.5 shows the experimental setup for testing the squeeze MRE absorber. The base of the absorber was connected to a shaker (Vibration Test System, AURORA, Model No.: VG 100-8) that was controlled by the signal from the computer. The computer generated vibration signals which were then transferred to the power amplifier (Crown D-150A) via the Data Acquisition (DAQ) board (Type: LabVIEW PCI-6221, National Instruments Corporation U.S.A). The power amplifier was connected to the shaker. Two accelerometers (CA-YD-106 SINOCERA Piezotronics, Inc.) were used to measure the vibration of the base aluminum and absorber mass. The signals were amplified by the charge amplifier (YE5851A from SINOCERA Piezotronics, Inc) and then transferred to the computer by the DAQ board to process. One DC power supply (GW INSTEK GPC-3030D, GW GPR-3030D) was used to tune the currents of the coil to control the strength of the magnetic field in the electromagnets and the stiffness of the MRE. In this way the natural frequency of an MRE absorber can be controlled.

The software LabVIEW was used for the testing program. The vibration package was the essential part of this system, and it was used to generate the swept sine signals and to display and record the test results of the analysis of the MRE absorber. Two analog input channels and one analog output channel was designed for this testing program. The two analog input channels were connected to the two accelerometers to measure the frequency of the MRE absorber. The analog output channel was used to excite the shaker. The frequency range was determined by the starting frequency and ending frequency.

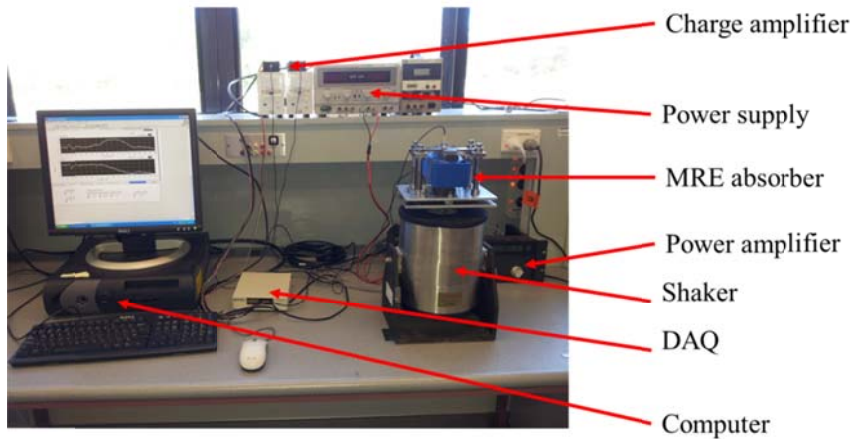

Fig.5 The system for evaluating the squeeze MRE absorber

Six currents ranging from 0A to 2.5A were applied to the MRE in this experiment. Figs.6 and 7 indicate the transmissibility of the squeeze mode MRE absorber; these Figures show that as the current varied from 0A to 2.5A the natural frequency of the squeeze working mode MRE absorber increased from 37Hz to 67Hz.

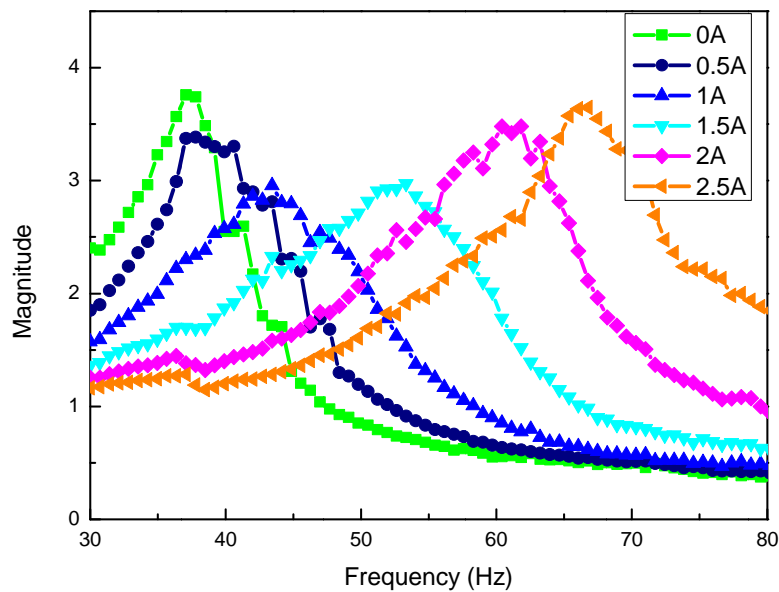

Fig.6 The transmissible magnitude of the squeeze MRE absorber versus frequency at various magnetic strengths.

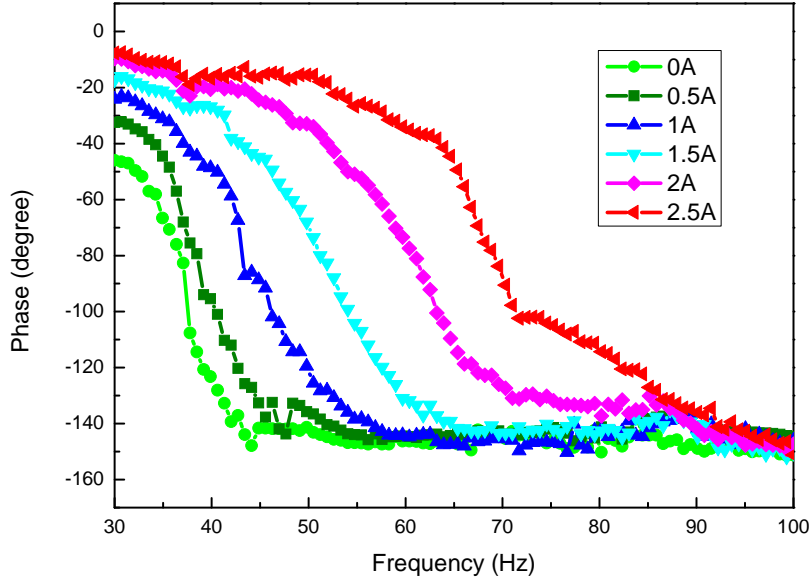

Fig.7 The phase transmissibility of the squeeze MRE absorber versus frequency at various magnetic strengths.

#### 4. Theoretical analysis of the squeeze working mode MRE absorber.

In order to investigate the performance of the squeeze working mode MRE absorber, a theoretical model was built to predict the shift in frequency of an MRE absorber working in squeeze mode. Based on this model, the effect that the magnetic strength had on the natural shift of frequency is discussed.

The natural frequency of the squeeze working mode MRE absorber can be written as:

$$f = f_b + \Delta f \quad (3)$$

Where  $f_b$  is the initial natural frequency and  $\Delta f$  is the shift in frequency induced by the magneto:

$$f_b = \frac{1}{2\pi} \sqrt{\frac{E_0 A}{mh}} \quad (4)$$

$$\Delta f = \frac{1}{2\pi} \sqrt{\frac{E_0 A}{mh}} \left( \sqrt{1 + \frac{\Delta E}{E_0}} - 1 \right) \quad (5)$$

Where  $E_0$  is the initial modulus of the MRE,  $A$  and  $h$  are the effective area and thickness of simple MRE,  $m$  is the mass of the oscillator,  $\Delta E$  is the magnetically induced compressive modulus which was measured and shown in Fig. 3.

Magnetic dipole model, which assumes the iron particle as magnetic dipole, ignores the interaction between external magnetic field and magnetic field of particles. This assumption in this mode may lead to some calculation error. However, this model can correctly predict the trend. Also, the magnetic dipole model has the advantage of simple and convenient to derive and easy to obtain explicit solution. Thus, magnetic dipole method was used to predict the dynamic property of MRE absorber in this section. Based on the magnetic dipole method, a theoretical approach, as presented in the Appendix, was developed to predict the magnetically induced compressive modulus  $\Delta E$  under various magnetic strengths. Then the effect of oscillator mass and iron volume fraction on the frequency shift range was calculated as shown in Fig. 8. From Fig.8 (a), the increase of oscillator mass from 1Kg to 4 Kg decreased the frequency shift range from 37Hz to 19Hz. From Fig.8 (b), the increase of the volume fraction of particles from 0.2 to 0.5 increased the frequency shift range span from 4.4Hz to 73Hz. These two relationships provide good guidance to design the MRE absorber.

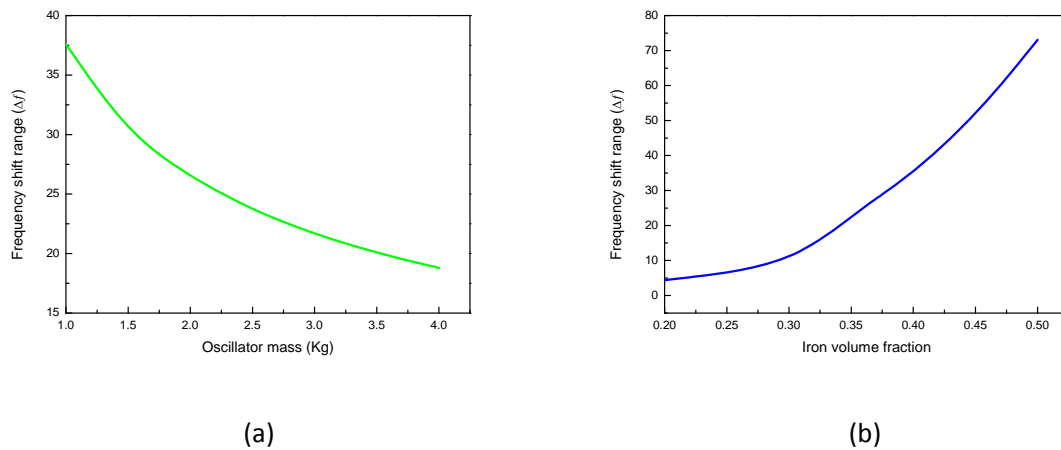

Fig.8 Relationships between frequency shift range and oscillator (a)/iron volume fraction (b)

A comparison of the simulation and experiment results of squeeze working mode MRE absorber is shown in Fig.9. The simulation results matched the experimental data quite well, which indicates that the model proposed to analyse the MRE absorbers working in squeeze modes predicted the frequency shift property of squeeze MRE absorbers quite well.

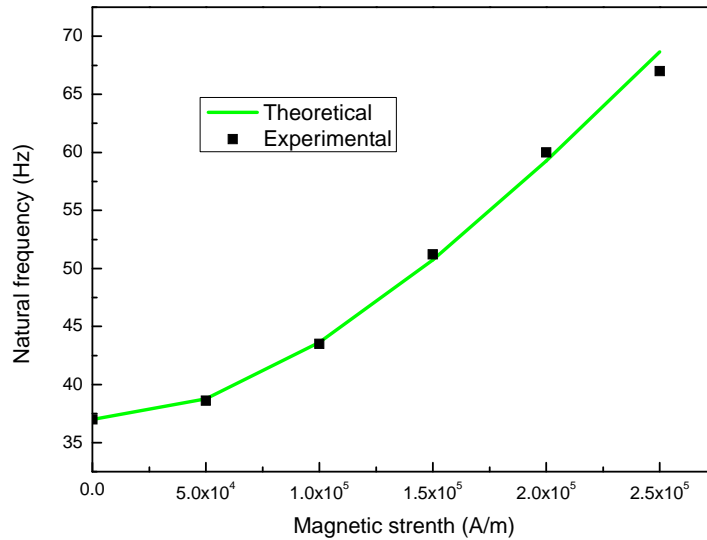

Fig.9 Comparison between experimental and simulation results of squeeze MRE absorber

### 5. The application of squeeze working mode MRE absorber on beam vibration absorption

In this section the squeeze MRE absorber was mounted onto a beam supported at each end to evaluate its vibration attenuation. As Fig.10 shows, a shaker that acted as an exciter was applied to provide sinusoidal excitation to the beam with a linear scan frequency ranging from 37Hz to 67Hz. The acceleration of the base point O under different coil currents were measured by the accelerometer. Then the vibration frequency of this beam was obtained by using a short time Fourier transform algorithm [31]. The relationship between the coil current and absorber's natural frequency can be obtained base on the theoretical model in section 4. According to the relationship between the coil current and absorber's natural frequency, the coil current can be controlled to trace the vibration frequency of beam. The squeeze MRE absorber with a fixed current was considered to be a passive absorber with a fixed natural frequency. The testing result is shown in Fig.11. The green curve shows the acceleration of beam without oscillator while the red curve and blue curve denote the acceleration of bean with passive and semi-active MRE absorber. The passive MRE absorber with a fixed natural frequency of 53Hz is realised by fixing the current in the coil. From the figure, it can be seen that the acceleration of the beam without oscillator maintained at approximately 3 m/s<sup>2</sup> before 14.4s then slightly decreased. The

application of the passive MRE absorber suppressed the beam's vibration to  $0.81\text{m/s}^2$  around 11s. However, as the excitation frequency is away from its natural frequency, its vibration attenuation effectiveness reduced, especially when the excitation frequency is higher than its natural frequency. The blue curve denotes the response of beam with the semi-active absorber. This curve indicates the semi-active absorber expand its effective frequency range from 3Hz to 67Hz. In order to evaluate vibration absorption capability of different absorbers, an acceleration ratio  $\gamma$  of base point O with and without the oscillator was used.

$$\gamma = a_w/a_o \quad (6)$$

where  $a_w$  is the acceleration of point O with the oscillator, and  $a_o$  is the acceleration of point O without the oscillator.

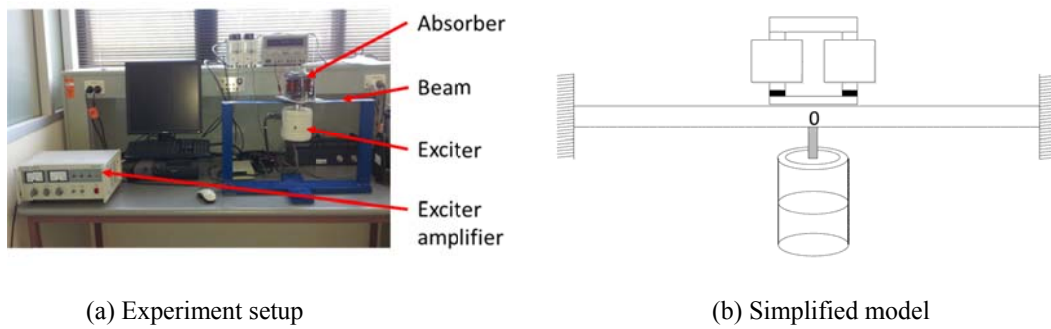

Fig.10 The system for evaluating vibration attenuation

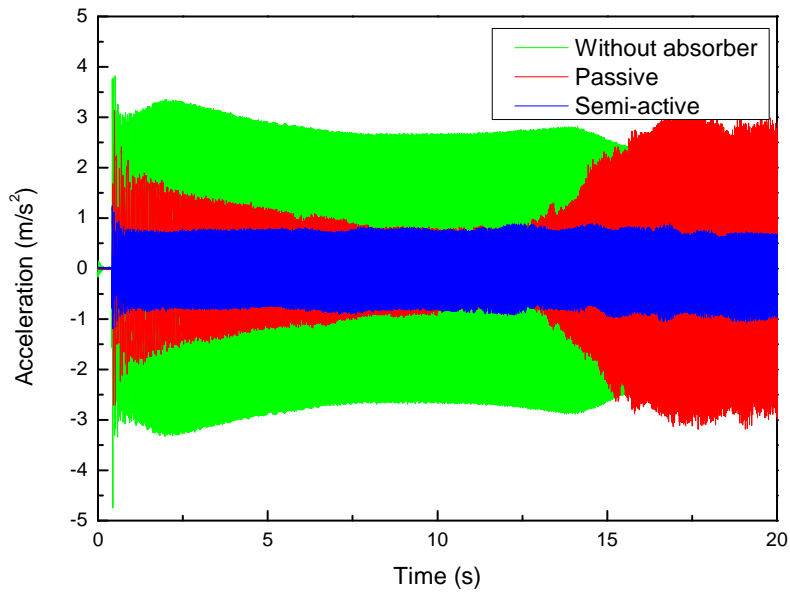

Fig.11. Response of the beam with passive absorber, semi-active absorber and without oscillator

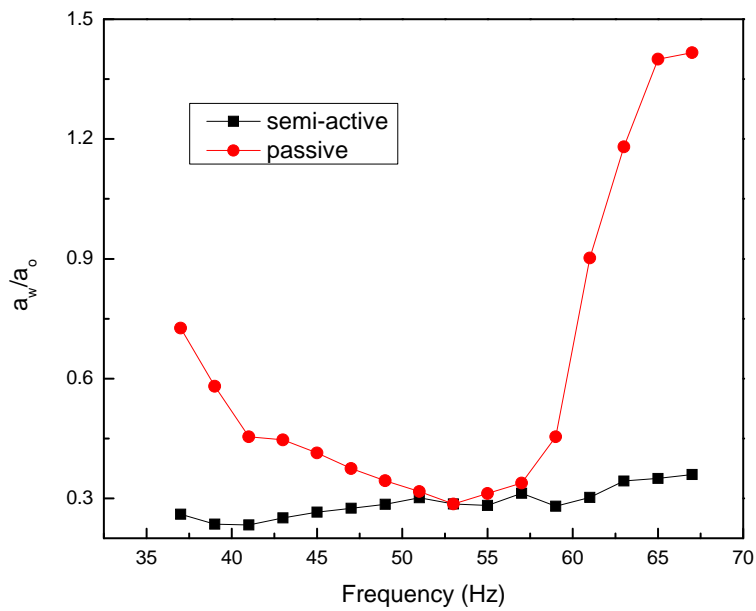

Fig.12 The result of vibration attenuation of absorbers

Fig.12 shows capability of the squeeze MRE absorber and passive MRE absorber to attenuate



vibration. The black line is the result of the passive MRE absorber and it indicates that the passive absorber performed the best when the frequency of the exciter was equal to 53Hz, which is its natural frequency. However, its ability to attenuate vibration decreased when the frequency of the exciter was away from its natural frequency. As a comparison, the red line shows the result of the semi-active squeeze MRE absorber when its tunable frequency traced the excitation frequency. This result indicates that the squeeze MRE absorber was effective from 37Hz to 67Hz and denotes that the semi-active squeeze MRE absorber was more effective than the passive absorber. By comparing the different capabilities of the passive absorber and squeeze working mode MRE absorber to attenuate vibration, the following conclusion can be drawn; first, because 53Hz is the natural frequency of the passive absorber, it has the same capability of suppressing vibration as the squeeze working mode MRE absorber when the frequency of excitation was 53Hz, and second, while the squeeze working mode MRE absorber retained the same capability of attenuating vibration under different frequencies of excitation, the ability of passive absorber to attenuate vibration kept decreasing such that the percentage of decrease reached 180% when the frequency of excitation decreased from 53Hz to 37Hz. A similar situation occurred when the frequency of excitation increased from 53Hz to 67Hz and the decreased in the capability of attenuating vibration reached 288%.

## **6. Conclusion**

In this paper a compact squeeze working mode MRE absorber consisting of an oscillator, four guide pillars, and MREs functioning as smart spring elements was developed. The experiment results proved that it could shift its natural frequency from 37Hz at 0A to 67Hz at 2.5A. The magnetic dipole based theoretical model developed in this paper can precisely predict the MRE absorber's shift in frequency. Finally, a beam supported at each end was used to evaluate whether the squeeze mode MRE absorber could attenuate vibration as well as the passive absorber. The results showed that the squeeze working mode MRE absorber suppressed vibration from 37Hz to 67Hz while the passive absorber was only effective around its natural frequency. This result proved that the squeeze working mode MRE absorber absorbed more vibration than the passive absorber.

## Acknowledgements

Funding for this work was provided by the National Natural Science Foundation of China (No. 51205100, No. 51328502), 111 project (No. B12019) and the University of Wollongong-China Scholarship Council joint scholarship (grant no.201206430031). This financial support is gratefully acknowledged.

## Appendix

### Calculating the magnetic induced compressive modulus $\Delta E$

As shown in Fig. A1,  $\vec{m}_1$  and  $\vec{m}_2$  are two magnetic dipoles and their distance is  $\vec{r}$ . According to classic magnetic dipole theory, the interaction energy between two magnetic dipoles is

$$E_{12} = \frac{1}{4\pi\mu_0\mu_1} \left[ \frac{\vec{m}_1 \cdot \vec{m}_2}{r^3} - \frac{3}{r^5} (\vec{m}_1 \cdot \vec{r})(\vec{m}_2 \cdot \vec{r}) \right] \quad (1.1)$$

The magnetic dipole moment of magnetic dipole  $i$  under a magnetic field is

$$\vec{m}_i = \frac{4}{3}\pi a^3 \mu_0 \mu_1 \chi H_i \quad (1.2)$$

Here,  $\vec{H}_i$  is the magnetic field of this particle,  $\chi$  is specific susceptibility of this particle,  $a$  is the radius of the particle, and  $\mu_1$  is the relative permeability of the silicon rubber. The magnetic field of the magnetic dipole  $i$  is not only affected by the extra applied magnetic field  $\vec{H}_0$  but also the magnetic field induced by particles around particle  $i$ . Thus the magnetic field which can magnetise particle  $i$  in the next chain is as follows:

$$H_i = \vec{H}_0 + 2 \sum_{j=1}^n \frac{3\hat{r}_j(\hat{r}_j \cdot \vec{m}_j) - \vec{m}_j}{4\pi\mu_0\mu_1 r_j^3} \quad (1.3)$$

Where  $\vec{m}_j$  is the magnetic dipole moment of particle  $j$ ,  $r_j$  is the distance between particle  $i$  and particle  $j$ , and  $\hat{r}_j$  is the unit vector in  $\vec{r}_j$  direction.

When only the interaction between particles in one chain is considered, and assuming that the distance between each particle is the same, then  $r_j = jr$ ,  $r$  is the average distance between two particles. By substituting equation (1.3) into (1.2) the following equation can be obtained.

$$\vec{m}_i = \frac{4}{3}\pi a^3 \mu_0 \mu_1 \chi [H_0 + 2 \sum_{j=1}^n \frac{3\hat{r} \cdot \vec{m}_j - \vec{m}_j}{4\pi\mu_0\mu_1 (jr)^3}] \quad (1.4)$$

Where  $\hat{r}$  is the unit vector in the  $\vec{r}$  direction. To assume that each particle has the same magnetic dipole moment,  $m_i = m_j = m$ . From equation 1.2, it can be obtained:

$$\vec{m}_i = \frac{4}{3} \pi a^3 \mu_0 \mu_1 \chi H_0 \left[ \frac{1}{1 - (4/3) \chi \zeta (a/r)^3} \right] \quad (1.5)$$

Where  $\sum_{j=1}^{\infty} 1/j^3 \approx 1.202$ . The interaction energy between two particles can be obtained:

$$E_i = 2\zeta \frac{|m|^2}{2\pi\mu_0\mu_1 r^3} \quad (1.6)$$

Then the magnetic energy of the MR elastomer, whose volume is V and volume fraction is  $\varphi$ , is obtained as follows:

$$E_z = \frac{\varphi V/2}{\frac{4}{3}\pi a^3} E_i \quad (1.7)$$

The density of magnetic energy is

$$E_a = \frac{E_z}{V} = \frac{3\varphi}{8\pi a^3} E_i \quad (1.8)$$

By substituting equation  $r = r_0(1 + \varepsilon)$  into the above equations,  $r_0$  is the initial distance of two adjacent particles,  $\varepsilon$  is compressive strain. If equation (1.8) is made a derivation of  $\varepsilon$  then the appended compressive stress induced by an extra magnetic field is as follows:

$$\delta = C \{ -3(1 + \varepsilon)^{-4} [1 - B(1 + \varepsilon)^{-3}]^{-2} - 2(1 + \varepsilon)^{-3} [1 - B(1 + \varepsilon)^{-3}]^{-3} [3B(1 + \varepsilon)^{-4}] \} \quad (1.9)$$

Where  $C = \frac{3\varphi\zeta}{8\pi^2 a^3 \mu_0 \mu_1} r_0^{-3} \left( \frac{4}{3} \pi a^3 \mu_0 \mu_1 \chi \vec{H}_0 \right)^2$

$$B = \frac{4}{3} \chi \zeta a^3 r_0^{-3}$$

Then the magnetic induced compressive modulus is

$$\Delta E = \frac{\delta}{\varepsilon} \quad (1.10)$$

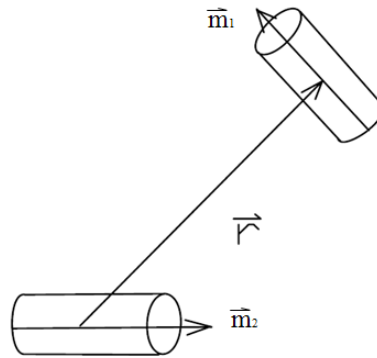

Fig. A1 The two magnetic dipole model with a distance of  $\vec{r}$

## References

- [1] H. FRAHM, "Vibrations of bodies," ed: US Patents No:989958, 1911.
- [2] E. Lee, *et al.*, "Design of a dynamic vibration absorber against vibrations in turning operations," *Journal of Materials Processing Technology*, vol. 108, pp. 278-285, 2001.
- [3] K. Liu and J. Liu, "The damped dynamic vibration absorbers: revisited and new result," *Journal of sound and vibration*, vol. 284, pp. 1181-1189, 2005.
- [4] C. L. Davis, *et al.*, "Tunable electrically shunted piezoceramic vibration absorber," in *Smart Structures and Materials*, 1997, pp. 51-59.
- [5] C. L. Davis and G. A. Lesieutre, "An actively tuned solid-state vibration absorber using capacitive shunting of piezoelectric stiffness," *Journal of sound and vibration*, vol. 232, pp. 601-617, 2000.
- [6] Y.-D. Chen, *et al.*, "Application of voice coil motors in active dynamic vibration absorbers," *Magnetics, IEEE Transactions on*, vol. 41, pp. 1149-1154, 2005.
- [7] H. Elmali, *et al.*, "Experimental comparison of delayed resonator and PD controlled vibration absorbers using electromagnetic actuators," *Journal of dynamic systems, measurement, and control*, vol. 122, pp. 514-520, 2000.
- [8] L. Kela and P. Vähöja, "Recent studies of adaptive tuned vibration absorbers/neutralizers," *Applied Mechanics Reviews*, vol. 62, p. 0801, 2009.
- [9] K. Nagaya, *et al.*, "Vibration control of a structure by using a tunable absorber and an optimal vibration absorber under auto-tuning control," *Journal of sound and vibration*, vol. 228, pp. 773-792, 1999.
- [10] P. Walsh and J. Lamancusa, "A variable stiffness vibration absorber for minimization of transient vibrations," *Journal of sound and vibration*, vol. 158, pp. 195-211, 1992.
- [11] X. Z.B., *et al.*, "Study on Mechanical Adaptive Tuned Vibration Absorber," *China Mechanical Engineering* vol. 30, pp. 1057-1061, 2009.
- [12] R. Morgan and K. Wang, "Active-passive piezoelectric absorbers for systems under multiple non-stationary harmonic excitations," *Journal of sound and vibration*, vol. 255, pp. 685-700, 2002.
- [13] E. Rustighi, *et al.*, "A shape memory alloy adaptive tuned vibration absorber: design and implementation," *Smart Materials and Structures*, vol. 14, p. 19, 2005.
- [14] X. Zhang and W. Li, "Adaptive tuned dynamic vibration absorbers working with MR elastomers," 2009.

- [15] J. D. Carlson and M. R. Jolly, "MR fluid, foam and elastomer devices," *Mechatronics*, vol. 10, pp. 555-569, 2000.
- [16] J. M. Ginder, *et al.*, "Magnetorheological elastomers in tunable vibration absorbers," in *SPIE's 8th Annual International Symposium on Smart Structures and Materials*, 2001, pp. 103-110.
- [17] G. H. Hitchcock, *et al.*, "Controllable magneto-rheological elastomer vibration isolator," ed: US Patents, 2006.
- [18] G. Liao, *et al.*, "The design of an active-adaptive tuned vibration absorber based on magnetorheological elastomer and its vibration attenuation performance," *Smart Materials and Structures*, vol. 20, p. 075015, 2011.
- [19] W. Li and H. Du, "Design and experimental evaluation of a magnetorheological brake," *The International Journal of Advanced Manufacturing Technology*, vol. 21, pp. 508-515, 2003.
- [20] G. Hu, *et al.*, "Experimental investigation of the vibration characteristics of a magnetorheological elastomer sandwich beam under non-homogeneous small magnetic fields," *Smart materials and structures*, vol. 20, p. 127001, 2011.
- [21] Z. Xu, *et al.*, "An active-damping-compensated magnetorheological elastomer adaptive tuned vibration absorber," *Journal of Intelligent Material Systems and Structures*, vol. 21, pp. 1039-1047, 2010.
- [22] H. Deng, *et al.*, "Development of an adaptive tuned vibration absorber with magnetorheological elastomer," *Smart materials and structures*, vol. 15, p. N111, 2006.
- [23] H. Deng and X. Gong, "Application of magnetorheological elastomer to vibration absorber," *Communications in Nonlinear Science and Numerical Simulation*, vol. 13, pp. 1938-1947, 2008.
- [24] C. Peng and X. L. Gong, "Active-Adaptive Vibration Absorbers and its Vibration Attenuation Performance," *Applied Mechanics and Materials*, vol. 312, pp. 262-267, 2013.
- [25] C. Kang, *et al.*, "Control system for an adaptive-active tuned vibration absorber based on magnetorheological elastomers," *Journal of Vibration and Shock*, vol. 6, p. 008, 2012.
- [26] N. Hoang, *et al.*, "A dynamic absorber with a soft magnetorheological elastomer for powertrain vibration suppression," *Smart Materials and Structures*, vol. 18, p. 074009, 2009.
- [27] N. Hoang, *et al.*, "Application of a magnetorheological elastomer to develop a torsional dynamic absorber for vibration reduction of powertrain," in *Electro-Rheological Fluids and Magneto-Rheological Suspensions: Proceedings of the 12th International Conference, Philadelphia, USA*, 2011, pp. 179-185.
- [28] K. M. Popp, *et al.*, "MRE properties under shear and squeeze modes and applications," *Journal of Intelligent Material Systems and Structures*, vol. 21, pp. 1471-1477, 2010.
- [29] A. A. Lerner and K. A. Cunefare, "Performance of MRE-based vibration absorbers," *Journal of Intelligent Material Systems and Structures*, vol. 19, pp. 551-563, 2008.
- [30] X. Zhang and W. Li, "Adaptive tuned dynamic vibration absorbers working with MR elastomers," *Smart Structures and Systems*, pp. 517-529, 2009.
- [31] S. Nagarajaiah and N. Varadarajan, "Short time Fourier transform algorithm for wind response control of buildings with variable stiffness TMD," *Engineering Structures*, vol. 27, pp. 431-441, 2005.