

University of Wollongong

## Research Online

---

Faculty of Engineering and Information  
Sciences - Papers: Part A

Faculty of Engineering and Information  
Sciences

---

1-1-2014

### A review of technical challenges in planning and operation of remote area power supply systems

Yingjie Tan

*University of Wollongong*, yt816@uowmail.edu.au

Lasantha Meegahapola

*University of Wollongong*, lasantha.meegahapola@rmit.edu.au

Kashem M. Muttaqi

*University of Wollongong*, kashem@uow.edu.au

Follow this and additional works at: <https://ro.uow.edu.au/eispapers>



Part of the [Engineering Commons](#), and the [Science and Technology Studies Commons](#)

---

#### Recommended Citation

Tan, Yingjie; Meegahapola, Lasantha; and Muttaqi, Kashem M., "A review of technical challenges in planning and operation of remote area power supply systems" (2014). *Faculty of Engineering and Information Sciences - Papers: Part A*. 2759.

<https://ro.uow.edu.au/eispapers/2759>

Research Online is the open access institutional repository for the University of Wollongong. For further information contact the UOW Library: [research-pubs@uow.edu.au](mailto:research-pubs@uow.edu.au)

---

# A review of technical challenges in planning and operation of remote area power supply systems

## Abstract

Remote area power supply (RAPS) systems are being used for many years to supply power to rural or remote communities where the utility grid is not accessible. In order to avoid the high operating cost and environmental impact caused by conventional generators, renewable energy resources are currently being utilised in RAPS systems. However, the intermittency of such renewable energy resources greatly impacts on planning and operation of RAPS systems. This paper aims to present a comprehensive review with regard to the RAPS system planning and operation techniques published in the literature. This paper summarises different modelling approaches associated with the RAPS system architectures, pre-feasibility studies for energy potential analysis, component modelling, unit size optimisation approaches, and system control aspects. In addition, technical challenges associated with RAPS systems, such as system sizing, voltage and frequency control and coordination of different system components are also highlighted in the paper. Moreover, further research avenues with regard to various different aspects of RAPS systems are also delineated in the paper.

## Keywords

challenges, planning, operation, remote, review, area, technical, power, supply, systems

## Disciplines

Engineering | Science and Technology Studies

## Publication Details

Y. Tan, L. Meegahapola & K. M. Muttaqi, "A review of technical challenges in planning and operation of remote area power supply systems," *Renewable and Sustainable Energy Reviews*, vol. 38, pp. 876-889, 2014.

# A Review of Technical Challenges in Planning and Operation of Remote Area Power Supply Systems

Yingjie Tan\*, Lasantha Meegahapola, Kashem M. Muttaqi

Australian Power Quality and Reliability Centre

School of Electrical, Computer and Telecommunications Engineering

University of Wollongong

New South Wales, Australia

\*E-mail: yt816@uowmail.edu.au

## Abstract

Remote area power supply (RAPS) systems are being used for many years to supply power to rural or remote communities where the utility grid is not accessible. In order to avoid the high operating cost and environmental impact caused by conventional generators, renewable energy resources are currently being utilised in RAPS systems. However, the intermittency of such renewable energy resources greatly impacts on planning and operation of RAPS systems. This paper aims to present a comprehensive review with regard to the RAPS system planning and operation techniques published in the literature. This paper summarises different modelling approaches associated with the RAPS system architectures, pre-feasibility studies for energy potential analysis, component modelling, unit size optimisation approaches, and system control aspects. In addition, technical challenges associated with RAPS systems, such as system sizing, voltage and frequency control and coordination of different system components are also highlighted in the paper. Moreover, further research avenues with regard to various different aspects of RAPS systems are also delineated in the paper.

## Keywords

Component optimisation, energy storage, remote area power supply (RAPS) system, renewable energy, rural electrification, solar-photovoltaic, system modelling, and wind generation.

## Nomenclature

RAPS	remote area power supply	DER	distributed energy resources
O&M	operation and maintenance	PCC	point of common coupling
PDF	probability density function	PV	photovoltaic
SOC	state of charge	LOEE	loss of energy expectation

LOLE	loss of load expectation	LOLF	loss of load frequency
ELCC	effective load carrying capability	COE	cost of energy
LCE	levelised cost of energy	CF	capacity factor
AI	artificial intelligence	GA	genetic algorithms
SA	simulate annealing technique	ANN	artificial neural network
MPPT	maximum power point tracking	DFIG	doubly-fed induction generator

## 1. Introduction

Remote area power supply (RAPS) system is a standalone power system that usually supplies power to small rural or remote communities. These communities do not have access to the utility grid, and it is technically and economically infeasible to extend the utility grid to remote regions. According to the international energy agency report, 1.3 billion people worldwide do not have access to electricity [1]. RAPS systems are considered to be a feasible option for electrification and highly promoted by the Energy Access Practitioner Network launched by the United Nations Foundation to ensure universal access to modern energy service [2]. Conventional generators such as diesel generator sets are widely being used in RAPS systems. However, due to the decreasing fossil fuel reserves, increasing fuel prices, as well as environmental issues, renewable energy resources are becoming more popular in RAPS systems.

The RAPS system can be defined as a small electricity network which serves a single property owner with very simple loads or several communities with complex and interconnected power stations [3]. However, different terminologies have been used in the literature to define RAPS systems, such as ‘standalone power systems’ [4], ‘off-grid power systems’ [5], ‘isolated power systems’ [6], ‘electrification power systems’ [7], ‘household power system’ [8], ‘mini-grids’ [9], ‘autonomous power systems’ [10], and in certain cases it is defined as a ‘microgrid’ [5, 11]. The typical feature of a RAPS system is being isolated from the main utility grid. The generators in a RAPS system supply power to a cluster of loads, and the system balances generation and demand autonomously. From this perspective, the terms like ‘standalone power systems’, ‘off-grid power systems’, and ‘isolated power systems’ are used due to the fact that RAPS systems are isolated from the main grid, whereas the term ‘electrification power system’ is used due to the fact that RAPS system are used for the rural electrification schemes. As defined by [12], mini-grids are centralised generation systems to provide electricity to small towns or large villages. Therefore, mini-grid is also another form of a RAPS system with a higher capacity. Similarly, ‘household power system’ is a kind of RAPS system with smaller capacity serving a single residential user. The ‘autonomous power

systems' are also designed for electrification of regions without large transmission networks. Their capacity can be ranging from a few hundred Watts to tens or hundreds of mega-Watts [13]. It can be seen that the definition of autonomous power systems is also similar to that of the RAPS system.

The Consortium for Electric Reliability Technology Solutions explored the potential of generation by locally available smaller distributed energy resources (DER) to meet customers' needs with the emphasis on reliability and power quality, and developed the concept of 'Microgrid', i.e. an aggregation of load and micro-sources operating as a single system providing both power and heat and presenting itself to the bulk power system as a single controlled unit [14]. Microgrids can operate in two modes: grid-connected mode, and islanded mode. Contrarily, RAPS systems always operate in standalone mode and do not inject or absorb any energy from the utility grid. Additionally, energy storage devices are commonly used in both microgrid and the RAPS system to mitigate the impact of fluctuation of non-dispatchable energy resources and improve system reliability, and utility grid can also be regarded as a storage system with an infinite capacity. Hence, storage devices may have relatively smaller capacity compared to the RAPS system of comparable size [15]. In microgrids, advanced communication infrastructures are usually applied to realise centralised control schemes [16, 17], which can be costly and impractical for RAPS systems considering the budget limitation as well as geographical constraints. As the microgrids are connected to the utility grid, certain power quality requirements such as voltage, frequency and harmonic emission must be maintained according to the utility grid-code standards at the point of common coupling (PCC). However, RAPS systems are not obliged to maintain such rigorous grid-code standards [15, 18]. Moreover, voltage and frequency at the PCC is commonly used as the reference for the microgrid, whereas a RAPS system has to establish its own voltage and frequency references. Therefore, it is inappropriate to use the same terminology to represent both the RAPS system and the microgrid. The aforementioned differences between microgrids and RAPS systems are summarised in Table 1.

**Table 1**

A Comparison between RAPS Systems and Microgrids

<b>Items</b>	<b>Microgrids</b>	<b>RAPS Systems</b>
<b>Utility Grid Availability</b>	Yes	No
<b>Energy Storage Devices</b>	Storage systems and grid	Storage systems
<b>Communication infrastructure</b>	Costly advanced techniques	No or normal techniques
<b>Performance Requirement</b>	Specific utility grid standards	Flexible
<b>Voltage and Frequency Reference</b>	Yield from PCC	Self-established

Nevertheless, microgrids and RAPS systems share some similarities. For example, in microgrids and RAPS systems, both conventional energy resources and renewable energy resources with smaller capacity are utilised. Energy resources are located at close proximity to the end-user and system voltages are at the low voltage level, so tie-lines are usually resistive rather than inductive as in the high voltage systems [19]. Therefore, some control strategies used in islanded microgrids can be readily applicable to RAPS systems and vice versa.

RAPS systems are becoming increasingly popular as a rural electrification option; hence it is a timely requirement to review the planning and operation techniques feasible for RAPS systems. Therefore, the main emphasis of this paper is to present a review on various planning and operational techniques, such as system architecture, renewable generator sizing and control techniques associated with RAPS systems. Ultimately, this will enable RAPS system designers to choose appropriate techniques to design an economically feasible and reliable RAPS system.

The review methodology of the paper is shown in Fig. 1. Section 1 briefly introduces the background information for RAPS systems, and clarifies common misinterpretations related to RAPS systems considering the characteristics of Microgrid systems. Section 2 presents a review of different RAPS system architectures and energy resources utilised in the RAPS system as well as RAPS system topologies. The pre-feasibility studies and component modelling techniques together with associated challenges are presented in Section 3 and Section 4 respectively. The unit size optimisation techniques and associated technical challenges are summarised in Section 5. Section 6 outlines the control strategies used in RAPS systems. Conclusions of the review are summarised in Section 7.

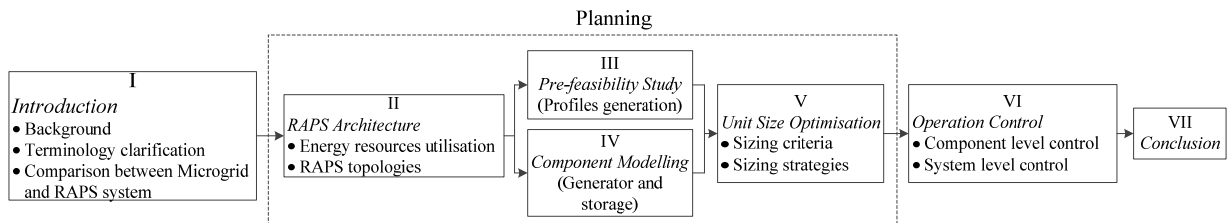

Fig. 1. The review methodology for RAPS system planning and operation techniques.

## 2. Technical Challenges on RAPS System Architectures

### 2.1. Energy Resource Utilisation

The RAPS systems can be mainly classified into three groups based on energy resource utilisation: single energy resource based RAPS system (e.g. diesel-only, wind-only, solar-only), hybrid RAPS system (e.g. diesel/wind, wind/hydro, diesel/wind/solar, etc.), and RAPS system with

storage system. The main advantage of the diesel generators based RAPS system is high reliability, however the following disadvantages defy its further expansion.

- Operating cost is very high due to the high fuel cost. The transportation cost of diesel is also increases the generation cost.
- The operating efficiency of diesel generators can be very low. A diesel generator indicates highest efficiency when the engine is loaded at around 70-80% of its rated capacity, and if the load is less than the half the rated capacity, then the generator will operate in an inefficient manner [20, 21]. Therefore, if the diesel generators are lightly loaded it will result in a very poor efficiency. Usually, the load in a RAPS system fluctuates frequently and the power factor can be very low. Installing generators of different rated capacities to operate under different load conditions increases loading level, but the high generation costs will not reduce.
- Diesel generators cause environmental problems, for example, noise, greenhouse gas emission, etc.

Therefore, diesel-only RAPS system is not considered to be a favourable choice and renewable energy resources, like wind, solar, hydro, etc. are currently being used in RAPS systems. However, a RAPS system with single renewable energy resource is not reliable due to the intermittency and variability of the renewable energy source. By combining renewable energy resources with diesel, the fuel consumption can be decreased due to the peak-shaving capability of renewable energy resources, and hence power output can also be smoothed. Nevertheless, the renewable energy resources are usually interfaced to the grid through inverters, which challenges the coordination with the conventional generator with inherent inertia [22]. This challenge is also discussed in Section 5. Hybrid system with wind and solar energy can make use of the complimentary characteristics of wind and solar energy to improve energy supply continuity and overall system efficiency, but the integration of two non-dispatchable energy resources further complicates the coordination process. Storage system acts as an energy buffer, storing surplus energy when generation is more than the load demand and releasing energy when load demand exceeds generation. The imbalance between generation and load demand can be significantly mitigated and system reliability can be improved dramatically [23]. Popular storage devices are lead-acid batteries, super-capacitors, flywheels, hydrogen, compressed air storage systems, etc. Storage devices add to RAPS system capital investment, and operation and maintenance (O&M) cost. Furthermore, complicated control strategy should be developed to protect the storage devices from damage and extend the life time of storage

[24]. Therefore, there is no easy way to evaluate energy resources potential for utilisation in a RAPS system.

## 2.2. RAPS System Topology

AC generator like diesel generator and wind turbine generator can either serve AC loads directly or convert AC power to DC power. Similarly, DC generator like solar-photovoltaic (PV) and fuel cells can either supply power to DC loads or invert DC power to AC power. Storage devices can be charged by DC generator directly or through converters. Hence, different RAPS system topology patterns can be developed: common AC-bus RAPS system, common DC-bus RAPS system, and hybrid-bus (i.e. combination of AC-bus and DC-bus) RAPS system. The different RAPS system topologies are illustrated in Fig.2.

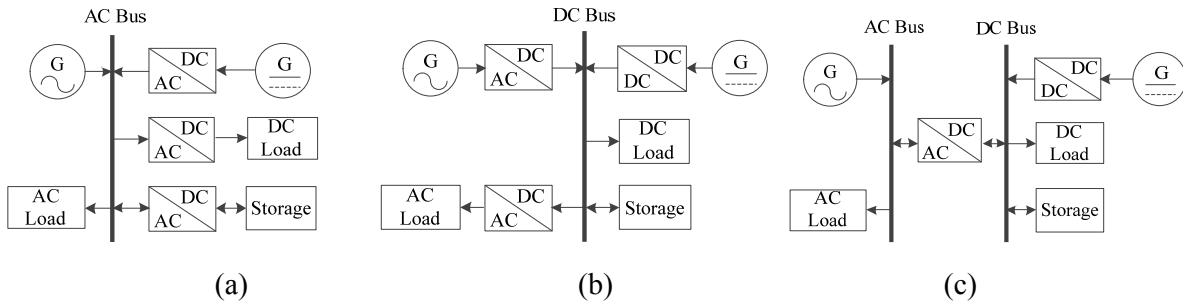

Fig. 2. RAPS system topologies: (a) Common AC-bus scheme; (b) Common DC-bus scheme; (c) Hybrid-bus scheme.

In a common AC-bus RAPS system [25] as shown in Fig. 12-(a), both the AC generator and DC generator are connected to the common AC bus. Therefore, inverters are used at the DC generator. The AC load absorbs energy from the AC bus and the DC load absorbs energy from the AC bus through converters. If storage system is installed in the system, it absorbs or injects power in order to achieve power balance between generation and load demand through bidirectional converters. Common DC-bus configuration is also widely being used in RAPS systems [4]. This RAPS system scheme is also referred as a series system in [20]. As shown in Fig. 2-(b), all the generated AC power is converted to the DC and subsequently converted to the AC in order to supply power to AC load. DC load and storage are connected to the DC bus. A Hybrid-bus RAPS system is shown in Fig. 2-(c), which is a combination of common AC-bus scheme and common DC-bus scheme. A comparison between three RAPS system topologies schemes considering the power conversion processing details are presented in Table 2. Table 2 is formed based the power conversion procedures that a type of generator (i.e. AC generator or DC generator) should go through to serve a particular type of load (i.e. AC load or DC load). An exception is the storage which can be regarded as either generator or load since storage systems can absorb or release energy.



**Table 2**  
Energy Conversion Processing Comparison

Generator \ Load	AC Load			DC Load			Storage		
	<i>A</i>	<i>B</i>	<i>C</i>	<i>A</i>	<i>B</i>	<i>C</i>	<i>A</i>	<i>B</i>	<i>C</i>
AC Generator	-	$\Delta\Diamond$	-	$\Diamond$	$\Diamond$	$\Diamond$	$\Diamond$	$\Diamond$	$\Diamond$
DC Generator	$\Delta$	$\circ\Delta$	$\circ\Delta$	$\Delta\Diamond$	$\circ$	$\circ$	$\Delta\Diamond$	$\circ$	$\circ$
Storage	$\Delta$	$\Delta$	$\Delta$	$\Delta\Diamond$	-	-	\	\	\

*A*, *B*, and *C* refers to common AC-bus scheme, common DC-bus scheme, and hybrid-bus scheme respectively.

“ $\circ$ ” - DC to DC conversion; “ $\Delta$ ” - DC to AC conversion; “ $\Diamond$ ” - AC to DC conversion; “-” - No conversion process; “\” - Not applicable.

From Table 1, it can be seen that power produced by the AC generator is supplied to AC directly in both common AC-bus scheme and hybrid-bus scheme whereas two conversion stages should be practiced in common DC-bus scheme. The AC/DC conversion is required in three schemes for providing energy to DC load and storage system from the AC generator. Hence, it can be concluded that, as far as efficiency is concerned, the AC generator has better performance in serving the AC load in common AC-bus scheme than the AC generator in common DC-bus scheme [26]. Hybrid-bus scheme has similar performance with common AC-bus scheme with regard to the AC generator. However, the storage system efficiency in powering the DC load is the lowest among the three schemes as two power conversion processes are required, whereas there is no need to convert power in other two schemes. This is also true for the DC generator in serving the DC load and storage, since an extra conversion stage should exist in common AC-bus scheme. Nevertheless, the DC to DC conversion stage can be eliminated for common AC-bus scheme as compared to the other two schemes in providing power to the AC load. Therefore, there is no easy way to draw the conclusion that which scheme is the best. The energy resources availability, load variability and storage system capacity are considered to maximise the system efficiency. Furthermore, system operating reliability also affects the decision and complicates the planning procedure. For example, the reliability of serving the DC load largely depends on the converter connecting the AC bus to the DC load in common AC-bus scheme. Such single point of failure also exists where AC load is connected to the DC bus in common DC-bus scheme. Although hybrid-bus scheme has higher overall operating efficiency as discussed in this section, it eliminates the single point of failure by the application of two buses. Moreover, the interconnecting bidirectional converter between the two buses is heavily burdened and control of the converter becomes more complex.

### **3. Technical Challenges on Pre-feasibility Study**

Pre-feasibility study is typically conducted to assess the potential of the generation to meet the load demand, and to assist in determining the component size. Pre-feasibility study is considered to be the first step for implementing an energy project [27]. Energy resources have different characteristics and their coordination in a RAPS system determines the performance and operating cost of a RAPS system. With conventional generators it is easy to estimate their power output which generally depends on the fuel consumption. However, some renewable energy resources, such as solar and wind energy, are weather dependent and their power output varies with the meteorological condition. Therefore, it is a challenging task to estimate power output from renewable energy resources. Generally, meteorological profiles are obtained to estimate the power production along with power characteristic of generators. As with weather dependent renewable energy generation, load demand profiles are also of high uncertainty. Usually, meteorological profiles and load profiles are generated in two approaches: chronological approach and stochastic approach.

#### **3.1. Chronological Approach**

In chronological approach, the meteorological profiles and load demand profiles are considered to be deterministic quantities and their variation with respect to time is determined with either historical data or synthesised data. In order to achieve high estimation accuracy, data sources like local meteorological stations or experimental measurements are typically being used. In [6, 7, 28-30], the hourly solar radiation data for the whole year was measured at the site. Wind speed data in [6, 29-31] was also obtained with the anemometers installed at the site. In order to yield a more accurate estimation of the power output from a solar-PV system, ambient temperature may also be taken into consideration; so temperature profile is also obtained during the measurement campaign [30].

There are some sites where complete records of meteorological data or load data are not available, the generation of profiles becomes a challenge. Three methods are commonly seen in literature to address this problem. Firstly, the authors in [21] use the wind profile of a neighbouring community as the wind profile at the site, which is also an acceptable option as recommended in [6]. Secondly, obtaining global meteorological data from internet might be another option [6]. Thirdly, incomplete data sets can be used to synthesise profiles using statistical algorithms and the selection of synthesising algorithms is also variable. Some optimisation tools have synthesising algorithms to generate profiles, such as HOMER (Hybrid Optimisation Model for Electric Renewables). The HOMER was developed by the US National Renewable Energy Laboratory which can synthesise solar radiation values for each of the 8760 hours of a year by using the Graham algorithm [8]. In [28]

the hourly load data was measured in a whole week and then average load profiles were obtained. In [8, 31], load profiles were generated by synthesising the load data in a typical day and then adding some randomness. For load profile studied in [30], it is generated by down-scaling an actual annual load profile of a larger RAPS system. In [8, 32], HOMER has been used to synthesise annual hourly solar radiation and wind speed profiles based on the monthly solar data and wind speed data obtained from National Aeronautics and Space Administration. In [33], a load profile in a village was studied by interpolating and averaging a 24-hour summer load profile and a 24-hour winter load profile over a one-year time period; then a second-order polynomial function is fitted to the daily profile. Similarly, solar insolation data for a village is fitted by a third-order polynomial function to obtain daily profiles.

Chronological approach is theoretically straightforward and simple to implement for reliability or cost analysis in feasibility study. However, the representation of future climate condition and load demand with historical data may inherently cause error in planning since climate conditions and load profiles vary from year to year. Accurate estimation of the error is beneficial but difficult to achieve and the compromise in estimating accuracy raises another topic, i.e. the determination of sizing margin in planning.

### 3.2. Stochastic Approach

Using stochastic approach, the availability of primary energy resources and load demand are considered as random variables; however, certain theories can estimate the probability of specific energy potential and load demand at a particular time instance. For example, the wind speed probability density functions (PDF) describe the frequency of occurrence of wind speeds at a particular site, that is, the likelihood that certain wind speed will occur at a particular time instance. Some characteristic parameters have to be assigned to those functions to match with the actual site conditions. Weibull PDF has been widely applied in wind energy conversion systems with the following form [34-36]:

$$f(v) = \frac{k}{c} \left(\frac{v}{c}\right)^{k-1} \exp\left[-\left(\frac{v}{c}\right)^k\right] \quad (1)$$

where  $f$  is the probability for a particular wind speed  $v$  at the site.  $k$  is called the shape parameter, and  $c$  is called the scale parameter. A special case of Weibull PDF is named as Rayleigh PDF when the shape parameter is equal to two. It must be noted that the Weibull PDF is unable to represent all the wind structures encountered in nature. One main limitation of the conventional Weibull PDF is that it does not accurately model calm winds and those with bimodal or even multimodal distributions resulting from special climatic conditions [37]. Other PDFs are developed to accommodate more

situations, such as truncated normal distribution[37], Gamma PDF[38], etc. Some mixture functions are also built to meet special cases where the single function is not suitable for simulating the actual wind speed [37, 39]. Similarly, PDF is also used to model solar irradiance distribution. Beta distribution is popular in literature [34-36, 40].

$$f(r) = \frac{\Gamma(\alpha+\beta)}{\Gamma(\alpha)\Gamma(\beta)} \left(\frac{r}{r_{max}}\right)^{\alpha-1} \left(1 - \frac{r}{r_{max}}\right)^{\beta-1} \quad (2)$$

where  $r$  and  $r_{max}$  ( $\text{W/m}^2$ ) are the actual and maximum solar radiance respectively,  $\alpha$  and  $\beta$  are the shape parameters of the distribution, and  $\Gamma$  is the Gamma function

$$\Gamma(x) = \int_0^{\infty} t^{x-1} \cdot \exp(-t) dt. \quad (3)$$

In [6], normal distribution is used to estimate the availability of solar irradiance. Solar irradiance distribution can also be approximated by superposition of two distribution functions. For example, it can be derived choosing two functions from normal, beta or Weibull distributions [41]. As for the load distribution, the simplest method assumes the load to be uniformly distributed between lowest load demand and highest load demand [40]. In [42, 43], the peak load demand is assumed to follow a probabilistic normal distribution. The approach suggested in [36, 43] arranges loads during a time frame in a descending order to form a cumulative load model which is known as load duration curve. The probability of load level  $l$  during the time frame is given by [34]

$$f(l) = \frac{\text{number of occurrences of load level } l}{\text{total number of load points during the time frame}}. \quad (4)$$

The challenges embedded in stochastic approach are multi folds:

- The PDFs of energy resources and load forecasting are varied from site to site, and these PDFs are determined based on the historical data. These data may not be available for the particular site, and the fitting of the data to a PDF may not be perfect which necessitates the error control.
- With the stochastic approach, the correlation between energy resource profiles as well as load profiles is usually ignored. The approach treats these profiles separately. In fact, wind speed and solar irradiance may have complementary characteristics and load can also be highly correlated with energy resources. Therefore, by considering the correlation among these profiles improves the calculation; however it is a challenging task.
- In a realistic model, wind speed, solar irradiance or load in a particular moment should not be independent of the values in previous moment. Taking the independence between adjacent time intervals into consideration significantly complicates the profile generation.

Deterministic and probabilistic approaches are two common strategies for feasibility study [6]. Deterministic approach is usually based on the profiles generated by chronological approach, which

is implemented in an iterative way and intensifies computational burden. Additionally, the study with chronological approach is not transparent, since the impact of characteristics of energy resources and load is not easy to be observed. On the contrast, the probabilistic strategy is based on profiles determined by stochastic approach, which provides more transparency. However, in a RAPS system with climate dependent energy resources and variable loads, the number of possible generation-demand scenarios can be enormous, which deteriorates the effectiveness of this strategy. When storage system is mounted or system device failure is considered, the probabilistic strategy is even harder to implement. Therefore, development of a proper method which simplifies the analysis while ensuring reasonable accuracy remains a challenging task.

## 4. Component Modelling

A RAPS system mainly consists of generators, loads, storage systems, and power conditioning units. Component models used for feasibility study represent the simple energy conversion processes from energy resources to electrical power. Solar generation, wind generation, diesel generation, and battery storage models are briefly discussed as follows.

### 4.1. Modelling Solar Generation

The available solar power on a PV array can be determined using [27]

$$P_{PV} = P_{PVr} f_{PV} I_T \quad (5)$$

where  $P_{PV}$  is the power output of a PV array,  $P_{PVr}$  is the rated capacity of a PV array,  $f_{PV}$  is the derating factor, and  $I_T$  is the total solar radiation on the surface of the PV array. The rated capacity of a PV array is the power produced when the solar radiation is  $1 \text{ kW/m}^2$  and cell temperature is  $25 \text{ }^\circ\text{C}$ . The derating factor is a factor which is used to scale down the ideal output of the PV array due to any other causes such as dust, wire losses and an elevated temperature.

### 4.2. Modelling Wind Generation

In a RAPS system, only a few wind turbine generators are used in comparison to a wind farm, therefore power output from wind generation can be estimated considering only one single generator and the impact of other wind turbine generators can be ignored. The specification provided by the wind turbine manufacturer describes the relationship between wind speed and power output of wind generator and the relationship is commonly presented as a power curve [44]. A wind turbine generator has a cut-in wind speed at which the generator starts to generate power, and a cut-off wind speed beyond which the generator is shut down for safety. Between the cut-in wind speed and the cut-off wind speed, the wind generator power output varies and spline interpolation functions are

used to fit those discrete wind speeds and corresponding power output of the generator as specified by the wind turbine manufactures. Hence, power output of the generator at any wind speed can be determined. The simplest model is a linear model [44], however quadratic equations can be used to fit each section of the power curve for high fitting accuracy [45]. A model based on the Weibull parameters can be found in [46] where Weibull shape parameter is incorporated to the fitting function. Quadratic model is a special case of the Weibull model, in which the shape parameter is two [47].

### 4.3. Modelling Diesel Generation

For a single diesel generator, the fuel consumption can be determined by [48]

$$C_d = AP_r + BP. \quad (6)$$

where  $P_r$  is the rated power,  $P$  is the actual power output.  $A$  and  $B$  are the coefficient of the fuel curve defined by the user. When biodiesel is used instead of diesel, fuel consumption is increased [30]. If only two operating modes are considered: rated operation and offline, then power output of the generator is  $P_r$  and zero respectively. The forced outage rate is used to estimate the failure and repair frequency (offline probability) of the diesel generator [49].

### 4.4. Modelling Battery Storage

Storage system is an essential component in RAPS systems to ensure continuous power supply. Although many storage devices are available, such as supercapacitors, flywheels, and compressed hydrogen storage systems, batteries are still very popular due to their low cost and high energy density. State of charge (SOC) is the key index to indicate the battery capacity, and the SOC at the time  $t$  is given as [50]

$$SOC(t) = SOC(t - \Delta t) \cdot (1 - \delta) \pm \frac{I_c(t) \cdot \Delta t \cdot \eta_c}{C}. \quad (7)$$

where  $\delta$  is the self-discharging coefficient,  $I_c$  is the charging or discharging current,  $C$  is the nominal battery capacity and  $\eta_c$  is the battery charging efficiency which is taken as one during the discharging process. Positive sign in the equation represents battery charging process while negative sign represents discharging process. Capacity curve and lifetime curve are another two characteristics curves used for batteries. The capacity curve demonstrates the battery capacity in ampere-hours as a function of constant current discharging rate in amperes, whereas lifetime curve represents the number of cycles a battery can stand as a function of depth of discharge in each cycle [51].

In fact, all previously discussed models are approximate models. When accuracy is of priority, it is a great challenge to model the generator as well as storage system; hence more sophisticated

models should be developed to accommodate that task. For example, when taking the impact of cell temperature into consideration, the power produced by the PV array is determined by [30]:

$$P_{PV} = P_{PVr} f_{PV} I_T [1 + (T_c - 25)C_T] \quad (8)$$

where  $C_T$  is the PV temperature coefficient and  $T_c$  is the temperature of PV cells.  $T_c$  can be estimated using Eq. (9).

$$T_c = T_a + \frac{NOCT-20}{0.8} I_T \quad (9)$$

where  $NOCT$  is the normal operating cell temperature usually valued at 48 °C and  $T_a$  is the ambient temperature. If other factors such as shading and ventilation effects are non-negligible, the PV modelling complicates the process significantly.

Although the power output of wind turbine generators can be estimated based on models mentioned in Section 4.1.2, the power curve can only provide the power output as a function of average wind speed. Thus the instantaneous wind speed variations are ignored, which will affect the accuracy of the estimation. In [52] the power curve is modified to address this problem by considering both wind dynamics and the capability of capturing extra energy from a wind turbine generator. Other challenges like temperature and pressure corrections, unevenly distributed wind speed across the blade sweeping area, and tower spacing effect in wind farm are also required to be considered when improving the modelling accuracy.

## 5. Technical Challenges on Unit Size Optimisation

Under certain energy resources profiles and load demand profiles, size of the system components can be determined with proper modelling of the system components. The objective is to ensure power supply continuity while minimising generation cost.

### 5.1. Criteria for Unit Size Optimisation

Through the aforementioned pre-feasibility and system component modelling studies, the energy generation and load demand can be estimated. The capacity of the system components affects the power supply continuity directly. Particular standard should be set to choose proper capacity for the components and meet end-user's requirement. Power supply reliability and generation cost are two basic criteria used for RAPS system unit sizing. Reliability denotes the probability of generation to satisfy the load demand whereas the generation cost relates to capital investment, O&M cost, and environmental cost. In practice, unit sizing is subjected to some technical constraints as well.

### 5.1.1. Reliability Estimation Techniques

Different metrics are being used to determine the RAPS system reliability. The loss of load expectation (LOLE) and loss of energy expectation (LOEE) are two commonly used parameters to estimate reliability in power systems [53]. The LOLE is the average number of hours for which the load is expected to exceed the available capacity while the LOEE is defined as the expected energy that will not be supplied when the load exceeds the available generation. In [54], based on the reliability metric of LOLE, capacity value is defined as the additional load that a system can serve by adding a new generator while maintaining the same system reliability level. Capacity value can be denoted as effective load carrying capability (ELCC). The authors also suggest utilisation of storage system in a RAPS system decreases the LOLE value or increases the energy supply reliability level as shown in Fig. 3. The Fig. 3 also indicates a wind energy resource with high capacity value tends to balance the generation and load at a higher reliability level, and smaller nominal storage capacity is required to improve the system reliability to a target level.

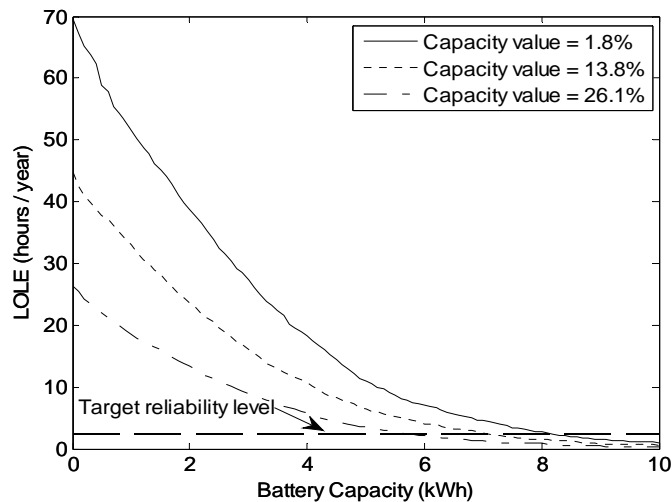

Fig. 3. Impact of storage on RAPS system reliability

The LOLE and LOEE are calculated by evaluating reliability with regard to the ELCC, which is demonstrated in [34, 55]. Contrarily, loss of load frequency (LOLF) may provide unmatched values even the same generation and load profiles are analysed. As suggested in [55], LOLF can be affected by the hour-to-hour variations in wind speed. The comparison between LOLE and LOLF in determining ELCC is shown in Fig. 4. Base case indicates the original system without additional generation. The 7.1 MW combustion turbine scenario is used to compare with the other two scenarios where 40 MW of wind generation with two different wind profiles is added into the original system. The combustion turbine scenario shares the same reliability level with wind generation scenario when only original load is considered. From Fig. 4, it can be seen that the LOLE



value is similar for three scenarios under various loading levels whereas the LOLF value varies significantly between combustion turbine scenario and wind generation scenario. Consequently, the ELCC obtained with the two indices can be far apart.

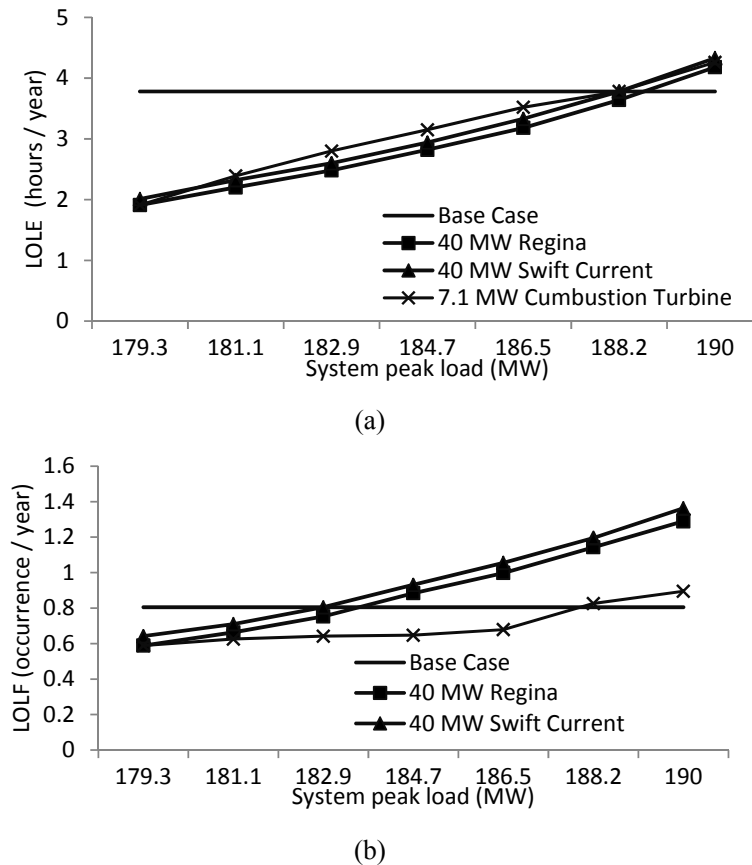

Fig. 4. ELCC obtained using LOLE and LOLF: (a) LOLE index; (b) LOLE index.

### 5.1.2. Cost Estimation Techniques

Various economic indicators are proposed in the literature to study economic feasibility of RAPS systems. The cost of energy (COE) is the ratio of summation of annualised capital cost and O&M cost to the amount of energy delivered [6]. The levelised cost of energy (LCE) is defined as the total cost of the whole hybrid system divided by the energy supplied from the hybrid system [50]. The life cycle cost is used in [5] which is comprised of capital cost, O&M cost, replacement cost, and fuel cost. The simple payback time is used in [33] to study the economic feasibility of integrating PV arrays into a diesel-battery RAPS system, and it is defined as the ratio of extra cost of the PV system and fuel savings made in a year. Unlike most of the literature related to the RAPS system economic analysis, a dynamic method is introduced in [56] taking into account the time component in evaluating investment. Environmental cost can also be taken into consideration. The avoided cost, which is defined as the ratio of COE savings and reduced emissions, is used to denote environmental

cost [33] while external costs representing estimations of the effects on both health and the degradation of the environment due to polluting emissions [5].

### 5.1.3. Constraints for Unit Size Optimisation

Number of constraints must be considered for unit size optimisation aiming for a technically feasible and cost-effective RAPS system. The available energy is limited due to the energy resource potential of a given site. In order to have a prolong battery life, charging and discharging current should be below its upper limit. Diesel generators are expected to be operating under proper loading level in order to avoid low efficiency. Budget limit is another crucial consideration. Assuming a battery with an initial zero state, the final stored energy level should not be negative at the end of the time horizon [6]. In [57], with the aim of minimising the system total cost, the balance between the generation and the load demand, the battery SOC limits, as well as the nominal capacities of PV arrays, are considered as constraints in the optimisation algorithm. A number of constraints are presented in [30] which include initial cost, the unmet load, capacity shortage, fuel consumption, renewable fraction and components' size. The operating reserve, which is defined as the operating capacity minus the electrical load, is used as the safety margin for a RAPS system in unit size optimisation algorithm presented in [27]. In [58], carbon dioxide emission is also regarded as one of the constraints.

## 5.2. Unit Size Optimisation Strategies

RAPS system unit sizing combines all the methodologies discussed in previous sections. Determining the optimal configuration for a RAPS system from a large number of feasible options can be a very challenging task for following reasons:

- Unit size optimisation is a multi-objective topic. Various factors as discussed in previous sections should be taken into consideration and the presentation of each factor can be a quite complicated task.
- Reliability and cost criteria usually contradict with each other, since a RAPS system of high reliability requires extra investment and vice versa. Therefore, trade-offs between the two criteria are inevitable in unit sizing depending on end-user requirements. The optimal configuration in [6] is selected based on the lowest cost of energy with a specified reliability level. The cost increases dramatically if a high reliability level is expected from the system. The solar-wind optimisation model developed in [50], which determines system configurations which meet the target reliability level, and subsequently the configuration with the lowest LCE is considered to be the optimal configuration. In [67],

priority is given to offered service rather than production cost, so reliability is highly emphasised.

- The design of an optimal RAPS system is heavily site dependent. At the site studied in [29], wind and solar-PV based RAPS system reduces system cost significantly compared to diesel-only, wind-only, and PV-only configurations due to the complimentary nature of the multiple renewable energy resources. Similarly, among the scenarios studied in [67], hybrid RAPS system with wind, solar-PV and diesel generator is also the best option although the COE is largely dependent on renewable energy potential and quality of supply. Nevertheless, renewable energy of high potential energy output is not necessarily the best option as analysed in [21]. Although wind capacity factor (CF) is higher than solar CF due to low cut-in wind speed for small wind turbines, PV system is chosen for its installation simplicity, lower capital and O&M cost. Moreover, RAPS systems are not always the best option for electrification when extending utility grid is feasible considering the distance between the remote area and the main grid, peak electrical load and load factor [68].

Therefore, various optimisation algorithms are proposed in the published literature to optimise the unit size [11, 27, 50, 59]. The optimisation techniques presented in the literature can be classified into two groups: enumeration technique and artificial intelligence techniques.

### **5.2.1. Enumeration Techniques**

Enumeration technique searches the optimum solution among different RAPS system configurations. The options are formed through changing the capacities of energy resources and storage systems in an iterative way. The configuration that best satisfies the optimisation criterion is chosen as the optimised configuration. In [50], the optimising procedure for a solar-wind system follows two steps. Firstly, with a particular storage size and reliability target, subsequently configuration with the lowest LCE can be determined by changing the number and the orientations of PV modules, and the rated capacity and tower height of the wind turbine. Secondly, a global optimum solution can be obtained by repeating step one with different storage sizes. Similarly, wind turbine generator, solar-PV, and battery sizes are determined in an iterative way on the condition of zero-load rejection with the minimum cost in [29], but only several sizes for solar-PV are explored. The optimum RAPS system configuration with minimum initial investment cost is explored from the possible instances by considering load density, load location, generator size and generator location [11]. The authors compare two mathematical formulations which use either integer or binary variables to define the location and size of the equipment while revealing the superiority of integer

model [11]. The technique proposed in [45] can narrow the searching space. The minimum size for the solar-PV and wind turbine to meet predesigned reliability level by assuming infinite capacity for batteries is determined first and subsequently maximum battery capacity can be found with the predetermined size of the solar-PV and wind turbine generator. Within the narrowed searching space for component sizes, the optimum configuration with the lowest COE is determined using the widely used enumeration technique. The sizing curves and design space introduced by [6] are formed to show all those feasible configurations that satisfy the load reliably, which benefits analysis of the impact of a specific system parameter on unit size optimisation.

Complete enumeration technique is the method applied by HOMER which is widely used for feasibility studies. Enumeration technique is a straightforward. However, the enumeration technique is challenged technically in two ways. One is that it is very computationally intensive as it explores solution iteratively through series of variable parameters and large amount of weather and load data. Actually, it is in fact a kind of trial and error process. To meet the intensive computation burden, costly computing devices are necessary and computation time can be quite long. The other challenge is that this technique may provide suboptimal solutions or local optimum [30, 58].

### **5.2.2. Artificial Intelligence Technique**

Due to those aforementioned demerits related to enumeration techniques, various artificial intelligence (AI) techniques are proposed and become alternatives for unit sizing. AI techniques have the ability to learn from examples, handle noisy and incomplete data, deal with non-linear problems, and perform prediction and generalisation at high speed [59]. Common AI techniques in literature include genetic algorithms, simulated annealing technique, and artificial neural networks.

*Genetic Algorithms (GA):* GA imitate the process of evolution of a population by selecting only the fittest individuals for reproduction [59]. GA is applied in [58] to determine optimal sizes for wind turbine generators, PV, and diesel generator. Fuzzy-c-mean is employed to identify states from chronological data to establish Markov models, which can greatly reduce the computational time when GA algorithm is used. The GA optimisation tool in MATLAB is used in [60] to size a hybrid PV-wind-diesel-battery RAPS system with the objective of cost minimisation and the condition that load is supplied at all times. Multiple objectives are managed in [61] using GA. A weighting factor is set for each objective in the fitness function to show design priority.

*Simulate Annealing Technique (SA):* SA is based on an analogy to the cooling of heated metals. In physics, annealing refers to the process of heating up a solid to a high temperature followed by slow cooling achieved by decreasing the temperature of the environment in steps [30]. SA is introduced by [62] to a PV–wind hybrid system. The system total cost is minimised through choosing proper PV

size, wind turbine rotor swept area and battery capacity using SA, and it is claimed that SA provides a better result than the response surface methodology. An optimisation of a RAPS model consisting of a PV, diesel and battery is solved using SA [63] with the objective of maintaining an optimum trade-off between energy cost and CO<sub>2</sub> emission. SA is capable of escaping from being trapped into a local optimum [30, 62, 63].

*Artificial Neural Network (ANN)*: ANN is a mathematical model based on biological neural network [64]. ANN can be trained by data sets and new data sets can be presented to it for process without being programmed to perform the task, hence it is cost effective and convenient. The greatest advantage of the ANN is the capability to model complex, non-linear processes without having to assume the form of relationship between input and output variables. ANN can address the issues like pattern matching, combinatorial optimisation, data compression, and function optimisation [59]. As for the RAPS system unit sizing optimisation, the ANN is usually combined with other AI to accomplish the task jointly.

AI techniques are also subjected to some technical challenges. For example,

- AI techniques are much more theoretically complex than enumeration technique.
- Limitations also exist for AI techniques. Although SA excels at gravitating towards the global optimum, it is not especially fast in finding the optimum in a given solution region [30]. In regard to GA, it is not effective when the problem is too large [59]. Similarly, as suggested in there is no guarantee that the ANN model can perform well for a particular problem. To mitigate the disadvantages of an individual AI technique, several AI techniques can be combined to solve an optimisation problem. The hybrid algorithm has the advantage of making use of the merits of each technique. A hybrid heuristic algorithm SA-Tabu search (TS) is introduced. SA provides initial solution for optimum and TS searches the given neighbourhood to find the optimum. In [61], a linear optimisation method which converges very fast starting from a precise point is used to re-optimize the solution obtained by GA. This hybrid approach converges to the global optimum faster than by using only GA. In [65], SA is used as a local search algorithm to prevent GA from converging to a local optimum in determining the minimum COE. The ANN-GA algorithm developed by [66] is verified to be able to generate the sizing curve for a RAPS system, and GA determines weights and/or architecture of the ANN when measured data are not available.

## 6. Technical Challenges on RAPS System Control Strategies

RAPS systems are generally expected to supply power continuously to end-users cost-effectively and efficiently. Designing such a RAPS system is far more than the planning process as mentioned in previous sections, and RAPS system control is of paramount importance. Several facts may account for the RAPS system control difficulties.

- Unlike utility grid to which upper limit of renewable energy resources penetration is usually assigned, the penetration of renewable energy resources in a RAPS system can be as high as hundred percent. The intermittency of the climate dependent energy resources results in fluctuations in power generation. Load can also be highly variable [9]. RAPS systems are more prone to be disturbed by generation fluctuations and sudden load changes. The variation in generation and load requires more robust voltage and frequency regulation, and energy management.
- Various energy resources and energy storage systems are utilised in RAPS systems, such as conventional and non-conventional, rotational and static, renewable and non-renewable sources, etc. The characteristics of different energy resources can be very different from each other. Therefore, coordinating all those energy resources in a single RAPS system is not an easy task.
- Nonlinear and single-phase loads occupy a large portion of the total load and deteriorate the voltage waveforms [67].
- It's impractical to implement high bandwidth communication due to the sparse distribution of DER as well as geographical constraints.
- In low voltage level network such as RAPS systems, large mechanical inertia usually does not present, especially when electronically interfaced generation dominates the system. Moreover, the power line is resistive rather than inductive generally, which may make some control theory widely used in utility grid invalid in RAPS system.

Nevertheless, as mentioned in Section 1, RAPS system shares similar control strategies with islanded microgrids, the control strategies be roughly classified into two layers: component-level control and the system-level control [68].

### 6.1. Component-Level Control Strategies

A RAPS system is mainly composed of generators, storage devices, load and converters as can be seen from RAPS architectures shown in Section 2. Nonconventional generators like microturbine, solar-PV and fuel cells, and storage devices like battery and flywheel are interconnected to the

system through converters. The converters play an important role in interfacing various energy resources to the RAPS system. Hence, component-level control strategies are mainly implemented at the converter. According to [69], the control objectives of converters can be grid-forming, grid-feeding, or grid-supporting.

### **6.1.1. Grid-Forming Control**

When a generator is connected to the utility grid, the utility grid can be regarded as an infinite bus, and voltage and frequency reference can be obtained from the PCC. However, in a RAPS system, no such bus exists. Hence, voltage and frequency reference must be generated internally. If a diesel generator is installed, it can provide the voltage and frequency reference [9]. Otherwise, converter is responsible for establishing voltage and frequency references for the system and holds system voltage and frequency constant. The master/slave control technique for inverters operating in parallel is such an example [70]. The master converter maintains a constant sinusoidal wave output voltage and generates proper current commands for the slave converters. Permanent magnet synchronous generator based wind turbine is the only generator in the RAPS system introduced in [71]; so the interface inverter controls the system voltage and frequency under varying wind speed and load condition, and the maximum power point tracking (MPPT) strategy is implemented by the generator side DC to DC switch-mode converter. A control strategy is presented in [72], for a RAPS system with a doubly-fed induction generator (DFIG). In order to maintain the system frequency and voltage under contingencies, the grid-forming generators should have large enough capacity in case of disturbances. However, the challenge is, in RAPS systems, the generators have comparable capacities and there is usually no generator of dominant capacity.

### **6.1.2. Grid-Feeding Control**

Grid-feeding control is also referring to grid-following control as defined in [68]. Grid-feeding converters are usually controlled as current sources to export predefined active and reactive power. Nevertheless, the output of the renewable energy resources in a RAPS system can be intermittent and these energy resources are not dispatchable, which makes grid-feeding control difficult unless storage devices are connected with such energy resources or accurate power estimation technique is implemented. Although grid-feeding converters do not participate in the frequency and voltage control directly as grid-forming converters, they are capable to control voltage magnitude and frequency through active/reactive power control. Grid-feeding converters obtain voltage and frequency reference from the system and act as a current source. Current regulation is mainly based on either the  $dq$  synchronous reference frame or stationary reference frame [69]. The  $dq$  synchronous reference frame current regulation approach transforms AC signals to DC quantities, which makes it

simple to control using PI controller. In [73] the  $dq$  synchronous frame was adopted to control a single-phase inverter by constructing a second phase by shifting 90 degrees with respect to the single-phase signal. A stationary reference frame current regulator is proposed in [74]. The regulator overcomes the normal stationary frame regulator's steady-state error which occurs as result of the PI controller.

### **6.1.3. Grid-Supporting Control**

Grid-supporting converters can regulate the system frequency and voltage by adjusting the active and reactive power delivered to the system. Other auxiliary functions may also include balancing unbalanced load condition and mitigating of harmonics. A static synchronous compensator (STATCOM) is installed at the terminal of a self-excited induction generator (SEIG) to meet reactive load demand [75] in a petroleum extraction application. The STATCOM not only maintains the SEIG terminal voltage constant, but it will also balance the generating system under unbalanced loading conditions and filter the harmonics emitted by system loads.

## **6.2. System-Level Control**

In the utility grid, system-level control accounts for load and generation forecasting, unit commitment, economic dispatch, and security constraints [68]. In a RAPS system, system-level control performs similarly and has its own features as well. It is impossible for a RAPS system to ensure proper operation without the global knowledge of the system due to following reasons:

- Energy resources have different characteristics.
- Power output fluctuates due to weather depend nature of the renewable energy source.
- Minimum fuel cost and maximum renewable energy penetration are targeted.
- Energy storage devices are adopted and lay some constraints for control.
- Environmental impact is also considered.

Therefore, coordinated control strategies are required for the RAPS system components to operate in a cooperative and efficient manner. Furthermore, system level control strategies in the published literature can be classified into centralised and decentralised control strategies [55, 73-75].

### **6.2.1. Centralised Control Strategies**

Centralised control strategies operate based on communication facilities to enable the communication between the control centre and local controllers. Local controllers send information on operating conditions, such as the power output from the generators, voltage and frequency deviations, load demand estimations and charging status of storage systems, to the control centre. Control centre collects the information and makes optimising decisions on system power flow, and



then it assigns set points for the components in the system. The optimal objectives of centralised control can be system stability, minimisation of operating cost, life extension for system equipment, and the impact on environment.

The supervisory predictive control strategy developed in [24] for a wind/solar RAPS system computes the power references for wind and solar subsystems while minimising the operating cost. Local controllers control generators to deliver active and reactive power as specified by the central controller. Practical issues like extending equipment life time by reducing inrush or surge currents are considered for the optimal control. The optimal operation method suggested in [76] diverts short-term charging/discharging events induced by PV and load fluctuations to upper band of the battery SOC regime along with the operation of FC and electrolyser, hence, the impact on battery life can be reduced while reducing the operating cost.

In a RAPS system, demand side management is also an important part of centralised control, and the control strategy can be implemented at the customer load, dump load, and storage devices. A load shedding strategy is introduced by [77] to maintain stability of the wind-diesel RAPS system. The strategy determines the load to be shed at each stage using the under frequency relay, and the load shedding is minimised using GA. Penalty functions and chromosomes with varying lengths are utilised in the GA to determine the optimal number of loads to be shed at all stages. In [78], the load is divided into steps according to their priorities, and wind speed is also divided into different levels; subsequently each load step can be supplied by the wind turbine generator when wind speed varies between two predefined wind speed levels. With this load control strategy, energy storage devices are not necessary in the RAPS system. If energy storage device is installed, then the surplus energy is usually absorbed by the energy storage system when the generation is more than the load demand. However, if the storage devices are full, then the extra energy should be consumed by other means, since overcharging of storage devices like lead-acid batteries will harm the storage devices. Dump load such as space heating is commonly used in RAPS systems for energy balancing purposes [72]. A dump load power control strategy is introduced by [4] in order to eliminate the actual dump load and to prevent battery overcharging, hence, the lifetime of the batteries can be extended and system cost can be reduced.

Notable challenges for centralised control lay in the single point of failure and communication. The entire system is controlled through the central controller. On the one hand, if the controller fails, the whole system collapse and system reliability level decreases. On the other hand, effective centralised control demands high speed communication among components. The high bandwidth communication links require extra investment and adversely impact on the RAPS system budget.

Additionally, complex communication techniques may be infeasible in some occasions when severe natural situations deteriorate its effectiveness.

### 6.2.2. Decentralised Control Strategies

On the contrast with centralised control strategy, decentralised control strategy does not need a control centre to determine an optimising decision. The components in a RAPS system with decentralised control make their own intelligent decision by communicating with each other using inherent communication channels. Following discusses the technical challenges on droop control strategy and multi-agent control strategy.

#### 6.2.2.1. Droop Control Strategy

The most widely adopted strategy to ensure real and reactive power sharing among generators without communication infrastructure is the droop control strategy. The system frequency and voltage magnitude are maintained in accordance to the active and reactive power deviation from the pre-specified requirement. For conventional generators, the active power ( $P$ ) output mainly depends on the power angle or the frequency while the reactive power ( $Q$ ) is mainly determined by the voltage magnitude. Therefore, the conventional frequency droop and voltage droop have the following form [79].

$$\omega = \omega_r - k_p (P - P_r) \quad (10)$$

$$V = V_r - k_q (Q - Q_r) \quad (11)$$

where  $\omega_r$  and  $V_r$  are the nominal frequency and voltage respectively,  $\omega$  and  $V$  are the actual frequency and voltage respectively,  $S = \sqrt{P_r^2 + Q_r^2}$  is the rated capacity of the generator, and  $k_p$  and  $k_q$  are the frequency droop and voltage droop constants respectively. Several technical challenges are common for droop control strategy.

*Frequency and voltage deviation:* With droop control, system frequency and voltage magnitude will generally vary with the fluctuation of load demand. However, the deviations of frequency and voltage are expected to be within acceptable limits. Regulating techniques are required to satisfy the requirement. In [80], frequency droop is applied for real power management in an islanded microgrid. The system frequency deviation can be minimised by adjusting frequency droop characteristic, and frequency restoration technique is also integrated into the real power controller. A recent work presented in [81] proposes the *arctan* droop control which ensures the operational frequency is always within preset bounds.

*Impact of line impedance:* Line impedance unbalance may degrade the load sharing accuracy, although the authors in [79] claim that the impact is not necessarily a disadvantage since the

generators that are located electrically far from the load centres automatically deliver a lower share of power with  $P/V$  droop control, and thus line losses can be reduced in a resistive RAPS system. Due to the resistive nature of the line impedance in low voltage network, another form of droop controllers may be used in such system [69].

$$\omega = \omega_r + k_q (Q - Q_r) \quad (12)$$

$$V = V_r - k_p (P - P_r) \quad (13)$$

The reactive power sharing accuracy is enhanced using the improved droop control strategy developed in [82] for a low voltage RAPS system where real power and reactive power are inherently coupled. This strategy estimates the reactive power control error though injecting small real power disturbances and an integration term for reactive power sharing error elimination is added to the conventional voltage droop. In contrast to the conventional droop control, the output impedance of the inverters in [83] is enforced to be virtually resistive rather than inductive considering the resistive characteristic of the RAPS system network. Such a resistive droop method has good power sharing performance with low sensitivity to the line impedance unbalance.

*Nonlinear loads:* the droop control strategy presented in literature is generally verified to operate well with linear load. In fact, nonlinear loads can present a high portion of the total load and have a strong impact on voltage waveforms in a weak power system such as RAPS system [67]. The voltage at the load side can be highly distorted. In order to address the harmonic current sharing problem, several control strategies appear in literature [80, 82-83]. The harmonic current sharing strategy for each order of harmonics developed by [84] is based on the conventional droop control for fundamental voltage and frequency. This strategy enables to equally share nonlinear loads among converters connected in parallel. An instantaneous current control loop can be implemented to program the output impedance to be resistive, and then the harmonic current can be shared without increasing the voltage distortion too much [85]. The same authors apply similar resistive output impedance for harmonic current sharing in [83], but the output impedance presented to the fundamental and harmonic components are fixed independently, to avoid the excessive increase of output voltage total harmonic distortion. In [86], droop control and average power control are combined to share both linear and nonlinear load, and a harmonic control loop is proposed to guarantee harmonic power sharing using low-bandwidth communication to enable the power information exchange among generators.

*Inertia coordination:* A high droop gain improves power sharing accuracy, but it worsens the stability. Virtual inertia is applied to the DFIG in [87] with either rotating mass or super-capacitor. and the droop dynamic behaviour improves. When both conventional generators and inverter-based

generators present in a RAPS system, the control performance is affected by the different characteristics of conventional generators and inverter-based generators. For example, the rotational speed of the conventional generator cannot change instantaneously due to the inertia of the rotating mass whereas the inverter-based generator has little inertia responds to disturbances very fast. Additionally, reactive power supplied by the conventional generator is naturally related to the frequency and voltage respectively whereas control strategies have to be used to establish such relationship for inverter-based generators. The performance of different combinations of conventional generators and inverter-based generators in a RAPS system is compared in [22]. In the simulation, DG1 and DG2 are two generators and their capacity ratings are 2.5 MVA and 5 MVA respectively. The two generators share a load of  $5 \text{ MW} + j 3.5 \text{ MVAr}$  initially. Subsequently another load of  $1 \text{ MW} + j 1 \text{ MVAr}$  is added to the system followed by a decrease of  $0.5 \text{ MW} + j 0.5 \text{ MVAr}$ . The results for three different combinations of generators are shown in Fig. 5 to Fig. 7. The results indicate that the power can be shared in proportion to the capacity of generators in the systems with conventional generators only or inverter-based generators only. However, in the RAPS system consisting both conventional and inverter-based generators, the accuracy of power sharing is lower. Fig. 6 and Fig.7 also demonstrate that fluctuations present in the power output of the RAPS system consisting of inverter-based generator. In [9], the authors claim that the power output of the diesel generator will vary more in order to balance the generation and load demand due to the fluctuation of renewable generation in a diesel-wind RAPS system, which has a negative effect on diesel generator operation and may increase the O&M cost. A droop control strategy is proposed, which adjusts the frequency droop coefficient by varying the rotor resistance of the wound rotor induction generator as a function of system frequency under disturbances. Hence, the power output of the diesel generator can be smoothed and frequency deviation can also be mitigated. In [88], rather than operating under inherent  $P/f$  and  $Q/V$  droops, the  $P/V$  and  $Q/f$  droop are applied for synchronous generators to operate with converters compatibly in a resistive system,

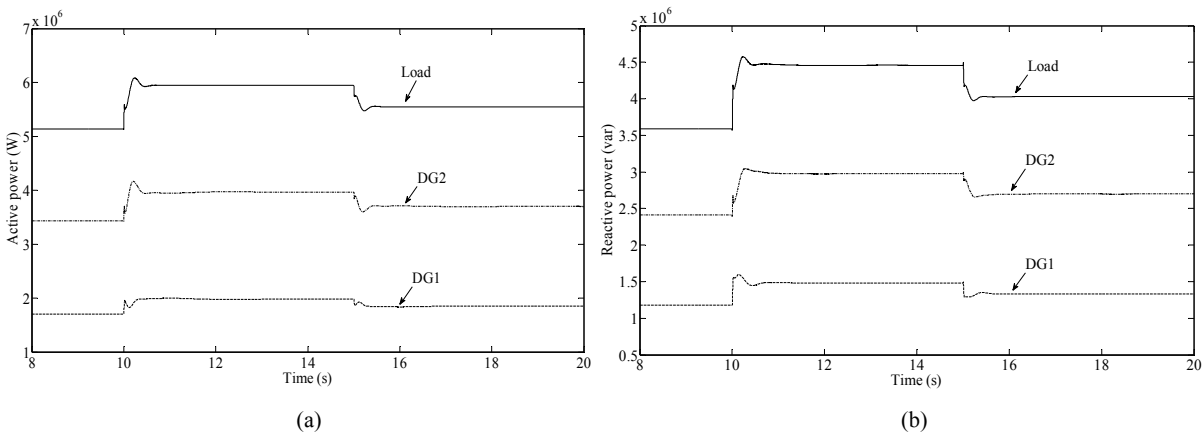

Fig.5. RAPS system with two conventional generators: a. Active power sharing. b. Reactive power sharing

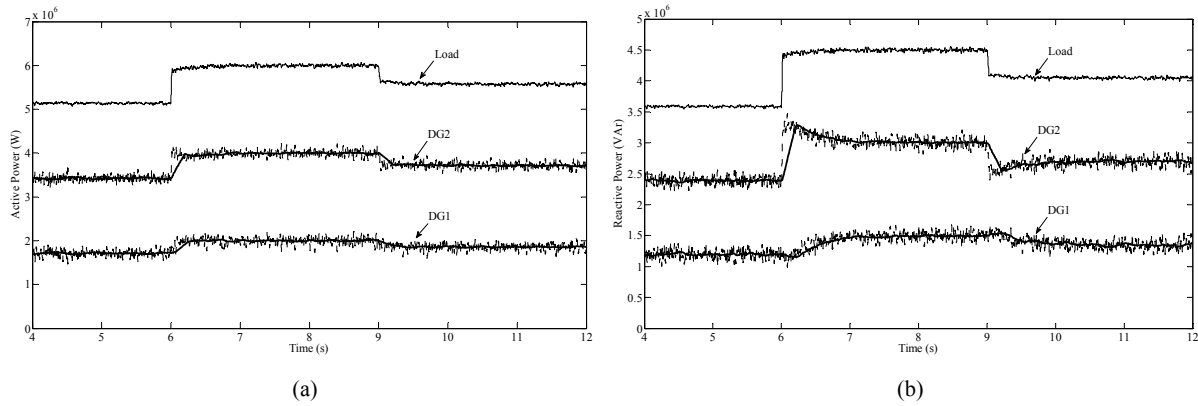

Fig.6. RAPS system with two inverter-based generators: a. Active power sharing. b. Reactive power sharing

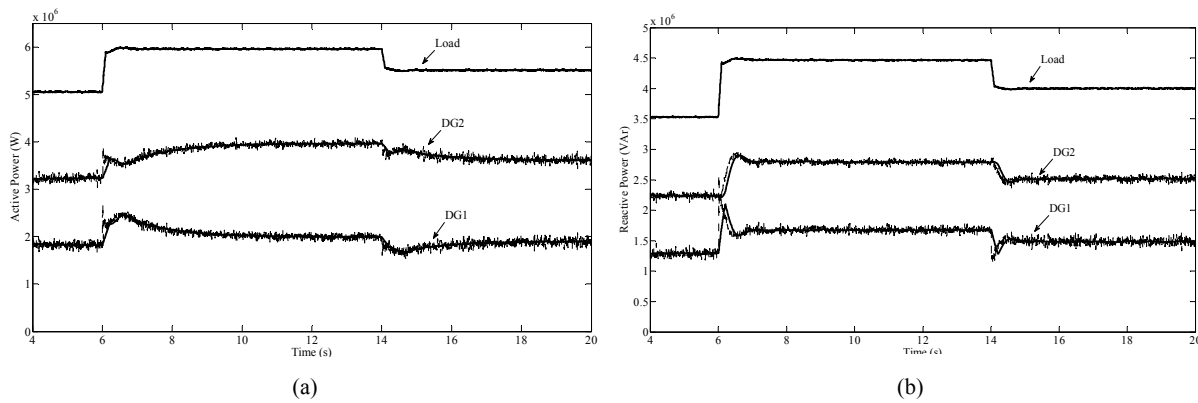

Fig.7. RAPS system with conventional and inverter-based generators: a. Active power sharing. b. Reactive power sharing

#### 6.2.2.2. Multi-Agent Strategy

The multi-agent system (MAS) is an evolved form of the classical decentralised control system with the feature of imbedded local intelligence in each agent. Each agent uses its intelligence to determine future actions and independently influences its environment [68]. In [89] a decentralised control system is designed based on MAS to coordinate. All the system components collaborate to reach a global coordination and the whole system can continue to work when the system configuration is changed, since the agents can adapt their behaviour to new conditions. Authors of [90] propose a dynamic demand response approach using MAS to optimise the energy management by controlling load and shifting loads to off peak hours. The approach reduces the energy consumption cost of the residential customers.

Centralised and decentralised control strategies can operate separately, and they can also be applied in a coordinated manner in a RAPS system. In [17], two main control strategies are investigated. 1) The single master operation strategy uses one voltage-source inverter (VSI) acting as master to provide voltage reference for the islanded microgrid and the others operating in  $PQ$  mode (slave). 2) The multi master operation strategy uses several VSIs to operate under droop control

strategy and the other inverters operating in  $PQ$  mode. Additionally, the control centre has the control over two operation strategies and it can modify generation profile by sending control information to generators. Droop control has formed the basic load sharing in [91], and wireless network plays the role of acquiring the information of the total real and reactive power generation of all generators. Using the collected information, the traditional droop control strategy is modified considering the difference between the desired and actual power generation and thus system stability can be improved.

## 7. Conclusions

A RAPS system based on renewable energy resources is considered to be an ideal electrification method for those areas where utility grid is not accessible. An up-to-date review of different planning and operation techniques is presented in this paper. In this review, it is revealed that the most important task in RAPS system planning is the study of energy potential of a proposed site either using chronological data series or stochastic information. In particular, it is essential to model the system components along with the renewable energy resources to accurately estimate the available energy at the site. In order to design a reliable, cost-effective, and environmentally friendly RAPS system, unit size should be optimised to meet particular cost and reliability target under certain design constraints and they are exemplified in this paper. The unit sizing is a multi-objective problem, hence appropriate optimisation techniques are required and they are generally classified into conventional enumeration techniques and AI techniques. In terms of RAPS system operation, two levels of control techniques, namely, component-level-control and system-level-control, are discussed. Component-level-control mainly refers to converters' roles in a RAPS system (i.e. grid-forming, grid-feeding, or grid-supporting) while centralised control and decentralised control including droop control and MAS technique are reviewed for system-level-control. In addition, a clarification of the terminology used for RAPS system and different RAPS system architectures are also presented in this paper. From this review, it can be concluded that both planning and operation techniques are essential to counteract the technical challenges associated with system sizing, unit cost of generation, voltage and frequency control and coordination of different system components in RAPS systems.

## References

- [1] International Energy Agency: World energy outlook 2013 - executive summary. <http://www.iea.org/publications/freepublications/publication/name.44381.en.html> 2013.
- [2] Energy access practitioner network: Towards achieving universal energy access by 2030. the United Nations Foundation; 2012.
- [3] Presnell K. Exporting australia's remote area power supply industry. *Renewable Energy* 2001;22:353-60.
- [4] Hirose T, Matsuo H. Standalone hybrid wind-solar power generation system applying dump power control without dump load. *IEEE Transactions on Industrial Electronics* 2012;59:988-97.
- [5] Thiam D-R. Renewable decentralized in developing countries: Appraisal from microgrids project in senegal. *Renewable Energy* 2010;35:1615-23.
- [6] Sreeraj ES, Chatterjee K, Bandyopadhyay S. Design of isolated renewable hybrid power systems. *Solar Energy* 2010;84:1124-36.
- [7] Gupta A, Saini RP, Sharma MP. Modelling of hybrid energy system—part iii: Case study with simulation results. *Renewable Energy* 2011;36:474-81.
- [8] Mondal AH, Denich M. Hybrid systems for decentralized power generation in bangladesh. *Energy for Sustainable Development* 2010;14:48-55.
- [9] Mipoung OD, Lopes LAC, Pillay P. Frequency support from a fixed-pitch type-2 wind turbine in a diesel hybrid mini-grid. *IEEE Transactions on Sustainable Energy* 2013;PP:1-9.
- [10] Tzamalīs G, Zouliās EI, Stamatakis E, Varkaraki E, Lois E, Zannikos F. Techno-economic analysis of an autonomous power system integrating hydrogen technology as energy storage medium. *Renewable Energy* 2011;36:118-24.
- [11] Ferrer-Martí L, Domenech B, García-Villoria A, Pastor R. A milp model to design hybrid wind–photovoltaic isolated rural electrification projects in developing countries. *European Journal of Operational Research* 2013;226:293-300.
- [12] Rolland S. Switched on to mini grids. *Renewable Energy Focus* 2011;12:10-2.
- [13] Zouliās EI, Lymberopoulos N. Hydrogen-based autonomous power systems: Techno-economic analysis of the integration of hydrogen in autonomous power. London: Springer; 2008.
- [14] Lasseter R. White paper on integration of distributed energy resources: The certs microgrid concept. Apr. 2002.
- [15] Dali M, Belhadj J, Roboam X. Hybrid solar–wind system with battery storage operating in grid-connected and standalone mode: Control and energy management – experimental investigation. *Energy* 2010;35:2587-95.
- [16] Farag HE, Abdelaziz MMA, El-Saadany EF. Voltage and reactive power impacts on successful operation of islanded microgrids. *IEEE Transactions on Power Systems* 2013;28:1716-27.
- [17] Peas Lopes JA, Moreira CL, Madureira AG. Defining control strategies for microgrids islanded operation. *IEEE Transactions on Power Systems* 2006;21:916-24.
- [18] Majumder R. Some aspects of stability in microgrids. *IEEE Transactions on Power Systems* 2013;28:3243-52.
- [19] Soni N, Doolla S, Chandorkar MC. Improvement of transient response in microgrids using virtual inertia. *IEEE Transactions on Power Delivery* 2013;28:1830-8.
- [20] Nayar CV. Recent developments in decentralised mini-grid diesel power systems in australia. *Applied Energy* 1995;52:229-42.
- [21] Arriaga M, Canizares CA, Kazerani M. Renewable energy alternatives for remote communities in northern ontario, canada. *IEEE Transactions on Sustainable Energy* 2013;4:661-70.
- [22] Tan Y, Muttaqi K, Meegahapola L. A droop control based load sharing approach for management of renewable and non-renewable energy resources in a remote power system. In: Australasian Universities Power Engineering Conference(AUPEC) 2013.
- [23] Billinton R, Bagen, Cui Y. Reliability evaluation of small stand-alone wind energy conversion systems using a time series simulation model. *Generation, Transmission and Distribution, IEE Proceedings-* 2003;150:96-100.
- [24] Wei Q, Jinfeng L, Xianzhong C, Christofides PD. Supervisory predictive control of standalone wind/solar energy generation systems. *IEEE Transactions on Control Systems Technology* 2011;19:199-207.
- [25] Newnham RH, Baldsing WGA. Advanced management strategies for remote-area power-supply systems. *Journal of Power Sources* 2004;133:141-6.
- [26] Ibrahim H, Younès R, Basbous T, Ilinca A, Dimitrova M. Optimization of diesel engine performances for a hybrid wind–diesel system with compressed air energy storage. *Energy* 2011;36:3079-91.
- [27] Martínez JA, Martín-Arnedo J. Tools for analysis and design of distributed resources-part i: Tools for feasibility studies. *IEEE Transactions on Power Delivery* 2011;26:1643-52.
- [28] Ismail MS, Moghavvemi M, Mahlia TMI. Design of an optimized photovoltaic and microturbine hybrid power system for a remote small community: Case study of palestine. *Energy Conversion and Management* 2013;75:271-81.
- [29] Kaldellis JK, Zafirakis D, Kavadias K. Minimum cost solution of wind–photovoltaic based stand-alone power systems for remote consumers. *Energy Policy* 2012;42:105-17.

- [30] Katsigiannis YA, Georgilakis PS, Karapidakis ES. Hybrid simulated annealing-tabu search method for optimal sizing of autonomous power systems with renewables. *IEEE Transactions on Sustainable Energy* 2012;3:330-8.
- [31] Asrari A, Ghasemi A, Javidi MH. Economic evaluation of hybrid renewable energy systems for rural electrification in iran—a case study. *Renewable and Sustainable Energy Reviews* 2012;16:3123-30.
- [32] Li C, Ge X, Zheng Y, Xu C, Ren Y, Song C, et al. Techno-economic feasibility study of autonomous hybrid wind/pv/battery power system for a household in urumqi, china. *Energy* 2013;55:263-72.
- [33] Wies RW, Johnson RA, Agrawal AN, Chubb TJ. Simulink model for economic analysis and environmental impacts of a pv with diesel-battery system for remote villages. *IEEE Transactions on Power Systems* 2005;20:692-700.
- [34] Khatod DK, Pant V, Sharma J. Analytical approach for well-being assessment of small autonomous power systems with solar and wind energy sources. *IEEE Transactions on Energy Conversion* 2010;25:535-45.
- [35] Sarkar S, Ajjarapu V. Mw resource assessment model for a hybrid energy conversion system with wind and solar resources. *IEEE Transactions on Sustainable Energy* 2011;2:383-91.
- [36] Karaki SH, Chedid RB, Ramadan R. Probabilistic performance assessment of autonomous solar-wind energy conversion systems. *IEEE Transactions on Energy Conversion* 1999;14:766-72.
- [37] Chang TP. Estimation of wind energy potential using different probability density functions. *Applied Energy* 2011;88:1848-56.
- [38] Zhou J, Erdem E, Li G, Shi J. Comprehensive evaluation of wind speed distribution models: A case study for north dakota sites. *Energy Conversion and Management* 2010;51:1449-58.
- [39] Akpinar S, Akpinar EK. Estimation of wind energy potential using finite mixture distribution models. *Energy Conversion and Management* 2009;50:877-84.
- [40] Abouzahr I, Ramakumar R. Loss of power supply probability of stand-alone photovoltaic systems: A closed form solution approach. *IEEE Transactions on Energy Conversion* 1991;6:1-11.
- [41] Khallat MA, Rahman S. A probabilistic approach to photovoltaic generator performance prediction. *IEEE Transactions on Energy Conversion* 1986;EC-1:34-40.
- [42] Castro RMG, Ferreira LAFM. A comparison between chronological and probabilistic methods to estimate wind power capacity credit. *IEEE Transactions on Power Systems* 2001;16:904-9.
- [43] Billinton R, N. Allan R. *Reliability evaluation of power systems*. 2nd ed. New York: Plenum Press; 1996.
- [44] Masters GM. *Renewable and efficient electric power systems*. 2 ed. Hoboken: Wiley; 2013.
- [45] Hocaoglu FO, Gerek ON, Kurban M. A novel hybrid (wind-photovoltaic) system sizing procedure. *Solar Energy* 2009;83:2019-28.
- [46] Prasad AR, Natarajan E. Optimization of integrated photovoltaic-wind power generation systems with battery storage. *Energy* 2006;31:1943-54.
- [47] Diaf S, Notton G, Belhamel M, Haddadi M, Louche A. Design and techno-economical optimization for hybrid pv/wind system under various meteorological conditions. *Applied Energy* 2008;85:968-87.
- [48] Dufo-López R, Bernal-Agustín JL. Multi-objective design of pv-wind-diesel-hydrogen-battery systems. *Renewable Energy* 2008;33:2559-72.
- [49] Noor SF, McDonald JR. Forced-outage rates of generating units based on expert evaluation. *IEEE Transactions on Reliability* 1996;45:138-40.
- [50] Yang H, Lu L, Zhou W. A novel optimization sizing model for hybrid solar-wind power generation system. *Solar Energy* 2007;81:76-84.
- [51] Helwig A, Ahfock A. Sizing nickel iron batteries for raps systems. In: *Renewable Power Generation (RPG 2011)*, IET Conference on 2011:1-4.
- [52] Zamani MH, Riahy GH. Introducing a new method for optimal sizing of a hybrid (wind/pv/battery) system considering instantaneous wind speed variations. *Energy for Sustainable Development* 2008;12:27-33.
- [53] Georgilakis PS, Katsigiannis YA. Reliability and economic evaluation of small autonomous power systems containing only renewable energy sources. *Renewable Energy* 2009;34:65-70.
- [54] Tan Y, Muttaqi K, Meegahapola L. Impact of capacity value of renewable energy resources on raps system energy management. In: *IET Renewable Power Generation Conference(RPG) 2013*.
- [55] Wangdee W, Billinton R. Considering load-carrying capability and wind speed correlation of wecs in generation adequacy assessment. *IEEE Transactions on Energy Conversion* 2006;21:734-41.
- [56] Mahmoud MM, Ibrik IH. Techno-economic feasibility of energy supply of remote villages in palestine by pv-systems, diesel generators and electric grid. *Renewable and Sustainable Energy Reviews* 2006;10:128-38.
- [57] Belfkira R, Zhang L, Barakat G. Optimal sizing study of hybrid wind/pv/diesel power generation unit. *Solar Energy* 2011;85:100-10.
- [58] Ying-Yi H, Ruo-Chen L. Optimal sizing of hybrid wind/pv/diesel generation in a stand-alone power system using markov-based genetic algorithm. *IEEE Transactions on Power Delivery* 2012;27:640-7.
- [59] Mellit A, Kalogirou SA, Hontoria L, Shaari S. Artificial intelligence techniques for sizing photovoltaic systems: A review. *Renewable and Sustainable Energy Reviews* 2009;13:406-19.
- [60] Merei G, Berger C, Sauer DU. Optimization of an off-grid hybrid pv-wind-diesel system with different battery technologies using genetic algorithm. *Solar Energy* 2013;97:460-73.



- [61] Zhao B, Zhang X, Li P, Wang K, Xue M, Wang C. Optimal sizing, operating strategy and operational experience of a stand-alone microgrid on dongfushan island. *Applied Energy* 2014;113:1656-66.
- [62] Ekren O, Ekren BY. Size optimization of a pv/wind hybrid energy conversion system with battery storage using simulated annealing. *Applied Energy* 2010;87:592-8.
- [63] Agarwala N, Kumarb A, Varun. Sizing analysis and cost optimization of hybrid solar-diesel-battery based electric power generation system using simulated annealing technique. *Distributed Generation & Alternative Energy Journal* 2012;27:26-51.
- [64] Zhou W, Lou C, Li Z, Lu L, Yang H. Current status of research on optimum sizing of stand-alone hybrid solar-wind power generation systems. *Applied Energy* 2010;87:380-9.
- [65] Carapellucci R, Giordano L. Modeling and optimization of an energy generation island based on renewable technologies and hydrogen storage systems. *International Journal of Hydrogen Energy* 2012;37:2081-93.
- [66] Mellit A, Kalogirou SA, Drif M. Application of neural networks and genetic algorithms for sizing of photovoltaic systems. *Renewable Energy* 2010;35:2881-93.
- [67] Prodanovic M, Green TC. High-quality power generation through distributed control of a power park microgrid. *IEEE Transactions on Industrial Electronics* 2006;53:1471-82.
- [68] Katiraei F, Iravani R, Hatziargyriou N, Dimeas A. Microgrids management. *IEEE Power and Energy Magazine* 2008;6:54-65.
- [69] Rocabert J, Luna A, Blaabjerg F, Rodri, x, guez P. Control of power converters in ac microgrids. *IEEE Transactions on Power Electronics* 2012;27:4734-49.
- [70] Mohd A, Ortjohann E, Morton D, Omari O. Review of control techniques for inverters parallel operation. *Electric Power Systems Research* 2010;80:1477-87.
- [71] Haque ME, Negnevitsky M, Muttaqi KM. A novel control strategy for a variable-speed wind turbine with a permanent-magnet synchronous generator. *IEEE Transactions on Industry Applications* 2010;46:331-9.
- [72] Mendis N, Muttaqi KM, Sayeef S, Perera S. Standalone operation of wind turbine-based variable speed generators with maximum power extraction capability. *IEEE Transactions on Energy Conversion* 2012;27:822-34.
- [73] Golestan S, Monfared M, Guerrero JM, Joorabian M. A d-q synchronous frame controller for single-phase inverters. In: *Power Electronics, Drive Systems and Technologies Conference (PEDSTC), 2011 2nd* 2011:317-23.
- [74] Zmood DN, Holmes DG. Stationary frame current regulation of pwm inverters with zero steady-state error. *IEEE Transactions on Power Electronics* 2003;18:814-22.
- [75] Singh B, Murthy SS, Gupta S. A stand-alone generating system using self-excited induction generators in the extraction of petroleum products. *IEEE Transactions on Industry Applications* 2010;46:94-101.
- [76] Tesfahunegn SG, Ulleberg Ø, Vie PJS, Undeland TM. Optimal shifting of photovoltaic and load fluctuations from fuel cell and electrolyzer to lead acid battery in a photovoltaic/hydrogen standalone power system for improved performance and life time. *Journal of Power Sources* 2011;196:10401-14.
- [77] Ying-Yi H, Po-Hsuang C. Genetic-based underfrequency load shedding in a stand-alone power system considering fuzzy loads. *IEEE Transactions on Power Delivery* 2012;27:87-95.
- [78] Schinas NA, Vovos NA, Giannakopoulos GB. An autonomous system supplied only by a pitch-controlled variable-speed wind turbine. *IEEE Transactions on Energy Conversion* 2007;22:325-31.
- [79] Vandoorn TL, De Kooning JDM, Meersman B, Guerrero JM, Vandeveld L. Automatic power-sharing modification of p/v droop controllers in low-voltage resistive microgrids. *IEEE Transactions on Power Delivery* 2012;27:2318-25.
- [80] Katiraei F, Iravani MR. Power management strategies for a microgrid with multiple distributed generation units. *IEEE Transactions on Power Systems* 2006;21:1821-31.
- [81] Rowe CN, Summers TJ, Betz RE, Cornforth DJ, Moore TG. Arctan power-frequency droop for improved microgrid stability. *IEEE Transactions on Power Electronics* 2013;28:3747-59.
- [82] Jinwei H, Yun Wei L. An enhanced microgrid load demand sharing strategy. *IEEE Transactions on Power Electronics* 2012;27:3984-95.
- [83] Guerrero JM, Matas J, Luis Garcia de V, Castilla M, Miret J. Decentralized control for parallel operation of distributed generation inverters using resistive output impedance. *IEEE Transactions on Industrial Electronics* 2007;54:994-1004.
- [84] Borup U, Blaabjerg F, Enjeti PN. Sharing of nonlinear load in parallel-connected three-phase converters. *IEEE Transactions on Industry Applications* 2001;37:1817-23.
- [85] Guerrero JM, Garcia de Vicuna L, Matas J, Castilla M, Miret J. A wireless controller to enhance dynamic performance of parallel inverters in distributed generation systems. *IEEE Transactions on Power Electronics* 2004;19:1205-13.
- [86] Marwali MN, Jin-Woo J, Keyhani A. Control of distributed generation systems - part ii: Load sharing control. *IEEE Transactions on Power Electronics* 2004;19:1551-61.
- [87] Arani MFM, El-Saadany EF. Implementing virtual inertia in dfig-based wind power generation. *IEEE Transactions on Power Systems* 2013;28:1373-84.

- [88] Vandoorn TL, Meersman B, De Kooning JDM, Vandeveldde L. Directly-coupled synchronous generators with converter behavior in islanded microgrids. *IEEE Transactions on Power Systems* 2012;27:1395-406.
- [89] Lagorse J, Simoes MG, Miraoui A. A multiagent fuzzy-logic-based energy management of hybrid systems. *IEEE Transactions on Industry Applications* 2009;45:2123-9.
- [90] Fazal R, Solanki J, Solanki SK. Demand response using multi-agent system. In: *North American Power Symposium (NAPS)*, 2012 2012:1-6.
- [91] Hao L, Bong Jun C, Weihua Z, Xuemin S. Stability enhancement of decentralized inverter control through wireless communications in microgrids. *IEEE Transactions on Smart Grid* 2013;4:321-31.