

University of Wollongong

Research Online

Faculty of Engineering and Information
Sciences - Papers: Part A

Faculty of Engineering and Information
Sciences

1-1-2014

A novel membrane distillation-thermophilic bioreactor system: biological stability and trace organic compound removal

Kaushalya Wijekoon

University of Wollongong, kcw998@uowmail.edu.au

Faisal Ibney Hai

University of Wollongong, faisal@uow.edu.au

Jinguo Kang

University of Wollongong, jkang@uow.edu.au

William Price

University of Wollongong, wprice@uow.edu.au

Wenshan Guo

University of Technology Sydney

See next page for additional authors

Follow this and additional works at: <https://ro.uow.edu.au/eispapers>



Part of the [Engineering Commons](#), and the [Science and Technology Studies Commons](#)

Recommended Citation

Wijekoon, Kaushalya; Hai, Faisal Ibney; Kang, Jinguo; Price, William; Guo, Wenshan; Ngo, Hao H.; Cath, Tzahi; and Nghiem, Long, "A novel membrane distillation-thermophilic bioreactor system: biological stability and trace organic compound removal" (2014). *Faculty of Engineering and Information Sciences - Papers: Part A*. 2308.

<https://ro.uow.edu.au/eispapers/2308>

Research Online is the open access institutional repository for the University of Wollongong. For further information contact the UOW Library: research-pubs@uow.edu.au

A novel membrane distillation-thermophilic bioreactor system: biological stability and trace organic compound removal

Abstract

The removal of trace organic compounds (TrOCs) by a novel membrane distillation-thermophilic bioreactor (MDBR) system was examined. Salinity build-up and the thermophilic conditions to some extent adversely impacted the performance of the bioreactor, particularly the removal of total nitrogen and recalcitrant TrOCs. While most TrOCs were well removed by the thermophilic bioreactor, compounds containing electron withdrawing functional groups in their molecular structure were recalcitrant to biological treatment and their removal efficiency by the thermophilic bioreactor was low (0-53%). However, the overall performance of the novel MDBR system with respect to the removal of total organic carbon, total nitrogen, and TrOCs was high and was not significantly affected by the conditions of the bioreactor. All TrOCs investigated here were highly removed (>95%) by the MDBR system. Biodegradation, sludge adsorption, and rejection by MD contribute to the removal of TrOCs by MDBR treatment.

Keywords

bioreactor, novel, trace, system, organic, distillation, thermophilic, compound, biological, membrane, removal, stability

Disciplines

Engineering | Science and Technology Studies

Publication Details

Wijekoon, K. C., Hai, F. I., Kang, J., Price, W. E., Guo, W., Ngo, H. H., Cath, T. Y. & Nghiem, L. D. (2014). A novel membrane distillation-thermophilic bioreactor system: biological stability and trace organic compound removal. *Bioresource Technology*, 159 (May), 334-341.

Authors

Kaushalya Wijekoon, Faisal Ibney Hai, Jinguo Kang, William Price, Wenshan Guo, Hao H. Ngo, Tzahi Cath, and Long Nghiem

**A novel membrane distillation – thermophilic bioreactor system:
Biological stability and trace organic compound removal**

Revised manuscript submitted to

Bioresource Technology

Feb 2014

Kaushalya C. Wijekoon^a, Faisal I. Hai^a, Jinguo Kang^b, William E. Price^b, Wenshan Guo^c, Hao H. Ngo^c, Tzahi Y. Cath^d, Long D. Nghiem^{a,*}

^aStrategic Water Infrastructure Laboratory, School of Civil Mining and Environmental Engineering, University of Wollongong, Wollongong, NSW 2522, Australia

^bStrategic Water Infrastructure Laboratory, School of Chemistry
University of Wollongong, Wollongong, NSW 2522, Australia

^cCentre for Technologies in Water and Wastewater,
School of Civil and Environmental Engineering, University of Technology Sydney, Sydney
NSW 2007, Australia

^dAdvanced Water Technology Center (AQWATEC), Department of Civil and Environmental Engineering, Colorado School of Mines, Golden, CO 80401, USA

* Corresponding author: Long Duc Nghiem, Email: longn@uow.edu.au; Ph +61 2 4221 4590

Abstract

The removal of trace organic compounds (TrOCs) by a novel membrane distillation - thermophilic bioreactor (MDBR) system was examined. Salinity build-up and the thermophilic conditions to some extent adversely impacted the performance of the bioreactor, particularly the removal of total nitrogen and recalcitrant TrOCs. While most TrOCs were well removed by the thermophilic bioreactor, compounds containing electron withdrawing functional groups in their molecular structure were recalcitrant to biological treatment and their removal efficiency by the thermophilic bioreactor were low (0 to 53%). However, the overall performance of the novel MDBR system with respect to the removal of total organic carbon, total nitrogen, and TrOCs was high and was not significantly affected by the conditions of the bioreactor. All TrOCs investigated here were highly removed (> 95%) by the MDBR system. Biodegradation, sludge adsorption, and rejection by MD contribute to the removal of TrOCs by MDBR treatment.

Keywords: Membrane distillation, thermophilic bioreactor, salinity build-up, biodegradation/transformation, adsorption, trace organic compounds (TrOCs).

1. Introduction

Water reclamation is a pragmatic approach to address the scarcity of water supplies in urban areas due to population growth and irregular climate pattern (Shannon et al., 2008). Through water reclamation, municipal wastewater can be a reliable alternative source for clean water supply. However, development of advanced treatment processes is necessary to ensure adequate removal of common contaminants (e.g., organics, nutrients, minerals) and especially trace organic compounds (TrOCs) that occur ubiquitously in municipal wastewater. These TrOCs include steroid hormones, pharmaceuticals, personal care products, surfactants, pesticides, disinfection by-products, and UV filters (Tran et al., 2013b; Zhao et al., 2010) that have been widely detected in raw sewage and reclaimed effluent from conventional wastewater treatment plants. Their occurrence is of major health and environmental concern because of their potential adverse impact on living organisms (Schwarzenbach et al., 2006). Thus, the removal of TrOCs during water reclamation has been the subject of intensive research in recent years.

Membrane bioreactor (MBR) is an efficient wastewater treatment technology, capable of producing reuse standard affluent (Melin et al., 2006). MBRs can effectively remove TrOCs that are hydrophobic and/or readily biodegradable (Boonyaroj et al., 2012; Clara et al., 2005; Tadkaew et al., 2011; Tran et al., 2013a); however, recent studies have highlighted the challenges of removing recalcitrant TrOCs (e.g., carbamazepine, diclofenac, etc.) by biological based treatment processes, including MBRs (Clara et al., 2005; Radjenović et al., 2009; Tadkaew et al., 2011; Wijekoon et al., 2013b).

Tadkaew et al., (2011) suggested that biodegradability of a TrOC can be qualitatively assessed based on the presence of electron donating functional groups (EDGs) or electron withdrawing functional groups (EWGs) in their molecules. They demonstrated that TrOCs with EDGs can be well removed in an MBR, whereas TrOCs with EWGs (such as chloride and amide) in their structure are usually poorly removed by MBRs. In a subsequent study, Wijekoon et al., (2013b) successfully extended this framework to elucidate the fate of TrOCs in the aqueous and sludge phases during MBR treatment. Given the resistance of some TrOCs to biodegradation, the use of post-treatment processes to specifically target these recalcitrant TrOCs has also been explored. Examples of these post-treatment processes subsequent to MBR treatment include reverse

osmosis (Alturki et al., 2010), activated carbon adsorption (Nguyen et al., 2013a), and ultraviolet oxidation (Nguyen et al., 2013b).

Integration of a high retention membrane process such as nanofiltration (Choi et al., 2002), forward osmosis (Achilli et al., 2009; Alturki et al., 2012; Hancock et al., 2013), or membrane distillation (MD) (Goh et al., 2013a; Goh et al., 2013b; Khaing et al., 2010; Phattaranawik et al., 2009) with a bioreactor constitutes a so called high retention MBR, which can be an efficient means to achieve high removal of pollutants. The working principles of these integrated processes have been demonstrated in recent studies; however, except for Alturki et al., (2012) and Hancock et al., (2011), the removal of TrOCs using these novel high retention MBRs has not been investigated.

MD is a low temperature distillation process that involves the transport of water vapour from a feed solution through the pores of a microporous and hydrophobic membrane to the distillate (product) side. Because mass transfer occurs in a gaseous phase, MD offers complete rejection of all non-volatile solutes (Curcio and Drioli, 2005). Membrane distillation bioreactor (MDBR) is a high retention MBR process where MD membrane can act as a barrier against the permeation of low molecular weight compounds and recalcitrant compounds. In the MDBR process, the biological reactor can be operated at thermophilic conditions to facilitate the integration of biological treatment with MD. In addition, the thermophilic bioreactor can also result in enhanced biodegradation of organics and low sludge yield (LaPara and Alleman, 1999).

The main aim of this study was to evaluate the performance of a novel hybrid MDBR process. Biological stability of the thermophilic bioreactor and the overall performance in terms of basic water quality parameters, as well as the fate and removal of TrOCs during MDBR treatment were elucidated.

2. Materials and Methods

2.1 MDBR Experimental setup

A laboratory-scale MDBR system consisting of a glass bioreactor and an external direct contact membrane distillation (DCMD) module was used (Fig.1). A peristaltic pump (Masterflex L/S, USA) was used to continuously transfer feed wastewater to the bioreactor. The bioreactor had an active volume of 5 L and was submerged in a water bath, which was equipped with an

immersion heating unit (Julabo, Germany) to keep the temperature at 40 ± 0.1 °C. It was also covered with aluminium foil to avoid any exposure to sunlight and heat loss. The bioreactor was aerated using an air pump (Risheng RS 9801, China) connected to a glass diffuser, and an overhead mixer (Heidolph Instruments, Germany) was used to maintain homogeneity within the bioreactor. The mixed liquor of the bioreactor was used as the feed to the external DCMD module.

[FIGURE 1]

The DCMD module was made of acrylic glass to minimize heat loss to the surroundings. The flow channels were engraved in each of two acrylic glass blocks that made up the feed and distillate semi-cells. The length, width, and height of each channel were 145, 95, and 3 mm, respectively. The total active membrane surface area for mass transfer was 140 cm^2 . Feed to the MD system (mixed liquor from the bioreactor) was continuously pumped to the membrane cell and recirculated back to the bioreactor. The temperature of the feed solution entering the MD cell was monitored using a temperature sensor connected to the feed line immediately outside the inlet. The temperature of the distillate leaving the membrane cell was monitored using another temperature sensor located immediately after the outlet of the distillate semi-cell. The temperature of the distillate was kept at 14.0 ± 0.1 °C using a chiller (Neslab RTE7, Thermo Scientific, USA) equipped with a stainless steel heat exchanging coil, which was directly immersed in the distillate reservoir. A glass container was used as the distillate reservoir and was placed on a digital balance (Mettler Toledo Inc, USA) to calculate the distillate flux. Excess distillate was pumped out from the distillate reservoir intermittently and collected in a stainless steel container for analysis. The MD feed and distillate flow rate were monitored using two rotameters and maintained at 1 L/min (corresponding to a cross flow velocity of 9 cm/s). Milli-Q water (2.25 L) was used as the initial distillate. The MDBR system was covered with insulation foam to minimize heat loss. A hydrophobic microporous polytetrafluoroethylene (PTFE) membrane (GE, Minnetonka, MN) was used. The average pore size, porosity, thickness and active layer thickness of this membrane were $0.22 \text{ }\mu\text{m}$, 70%, $175 \text{ }\mu\text{m}$ and $5 \text{ }\mu\text{m}$, respectively (Nghiem and Cath, 2011).

2.2. *Experimental protocol*

The bioreactor system was inoculated with activated sludge from the Wollongong Wastewater Treatment Plant (Wollongong, Australia). A synthetic wastewater was used to simulate medium strength domestic wastewater and to maintain stable operating conditions. The synthetic wastewater was prepared daily by diluting a concentrated stock with Milli-Q water to obtain 100 mg/L glucose, 100 mg/L peptone, 17.5 mg/L KH_2PO_4 , 17.5 mg/L MgSO_4 , 10 mg/L FeSO_4 , 225 mg/L CH_3COONa and 35 mg/L urea (Alturki et al., 2012). The concentrated stock solution was prepared every week and kept at 4 °C in the dark.

Prior to the MDBR experiment, the bioreactor was acclimatised at 40 °C by operating the system in an MBR mode using a ceramic microfiltration membrane module (NGK, Japan). During the acclimatisation period, the bioreactor was operated at a hydraulic retention time (HRT) of 24 h and a solids retention time (SRT) of 88 d. The temperature, dissolved oxygen (DO) concentration and conductivity of the mixed liquor were 40 °C, 2.8 ± 0.5 mg/L, and 425 $\mu\text{S}/\text{cm}$, respectively. The mixed liquor suspended solids (MLSS) concentration was 5.3 g/L, and under these operating conditions the mixed liquor pH remained stable at 7.6. More details about the ceramic MBR system are available elsewhere (Wijekoon et al., 2013b). After the bioreactor had been acclimatised for 75 d, the ceramic microfiltration membrane module was removed and the bioreactor was connected to the DCMD system. TrOCs were then continuously introduced to the influent at a concentration of approximately 5 $\mu\text{g}/\text{L}$ of each compound. MDBR operation was initiated at temperature and DO concentration of 40 °C and 2.8 ± 0.5 mg/L, respectively, and operated for 38 d. The HRT of the MDBR was 9.6 d due to the low distillate flux of the DCMD system. The basic biological performance of the MDBR in terms of total organic carbon (TOC) and total nitrogen (TN) removal, conductivity/pH variation, and MLSS concentration was continuously monitored. The mixed liquor was collected weekly and centrifuged at 3270 $\times g$ for 10 min (Allegra X-12R, Beckman Coulter, USA) to obtain the supernatant and sludge pellets for further analysis. Feed and distillate samples were collected for TrOC analysis on a weekly basis. The concentration of TrOCs in the distillate was calculated by taking into account the volume of Milli-Q water (2.25 L) used as the initial make up water.

TrOC removal by bioreactor (R_1), MD (R_2) and MDBR hybrid system (R_T) are defined as:

$$R_1 = 100 \times \left(1 - \frac{C_{Su}}{C_F}\right) \quad (1)$$

$$R_2 = 100 \times \left(1 - \frac{C_D}{C_{Su}}\right) \quad (2)$$

$$R_T = 100 \times \left(1 - \frac{C_D}{C_F}\right) \quad (3)$$

where C_F , C_{Su} , and C_D are concentration of the specific compound in the bioreactor feed, bioreactor supernatant, and distillate, respectively. Biodegradation/transformation of TrOCs during the treatment by the hybrid process was calculated by considering the mass balance of each compound in the feed, supernatant, sludge and distillate as given in Equation 4.

$$C_F \times V_F = (C_{Su} \times V_S) + (C_{Sl} \times X_{Sl} \times V_S) + (C_D \times V_D) + \text{biodegradation/transformation} \quad (4)$$

In Equation 4, C_{Sl} is the compound concentration in sludge and X_{Sl} denotes the sludge (MLSS) concentration. Similarly V_F , V_D , and V_S are the volume of the bioreactor feed, distillate, and mixed liquor, respectively.

2.3. Target Compounds

A set of 25 TrOCs (Table 1) was selected to represent pharmaceuticals and personal care products, steroid hormones, UV-filters, and pesticides that occur ubiquitously in municipal wastewater. These chemicals were obtained in analytical grade from Sigma-Aldrich (Saint Louis, MO, USA). A combined stock solution of all TrOCs was prepared in pure methanol and kept at -18 °C in the dark.

[TABLE 1]

2.4. Analytical methods

2.4.1 Basic water quality parameters

TOC and TN were analysed using a TOC/TN- V_{CSH} analyser (Shimadzu, Japan). Electrical conductivity and pH of the feed and distillate were monitored using an Orion 4 Star Plus portable pH/ conductivity meter (Thermo Scientific, Waltham, MA).

2.4.2 TrOC analysis

The concentration of TrOCs in the sludge phase (mixed liquor) was determined according to a method previously described by Wijekoon et al., (2013a). The solid pellets obtained from the mixed liquor after centrifugation (Section 2.2) were freeze-dried for 4 h using an Alpha 1-2 LDplus Freeze Dryer (Christ GmbH, Germany). The dried sludge was ground to powder and 0.5 g powder was transferred to a glass test tube for extraction. Methanol (5 mL) was added to the test tube, thoroughly mixed using a vortex mixer (VM1, Ratek, Australia) for 3 min, and ultrasonicated for 10 min at 40 °C. The sample was centrifuged at 3270 xg for 10 min (Allegra X-12R, Beckman Coulter, USA) and the supernatant was collected in a glass beaker for further analysis. Dichloromethane (5 mL) and methanol (5 mL) were added to the remaining sludge, and the process of mixing, ultrasonic extraction, and centrifugation was repeated. The supernatants from both steps were combined, Milli-Q water added up to a volume 50 mL, and the residual methanol and dichloromethane were purged using nitrogen gas. Finally, Milli-Q water was added to obtain a 500 mL aqueous sample. This sample was then analysed using the analytical method described below, and TrOC concentrations per gram of dry sludge were calculated.

TrOC concentrations in the aqueous phase were determined using a method previously reported by Hai et al., (2011b). This method consists of a solid phase extraction procedure followed by gas chromatography and quantitative determination by mass spectrometry with electron ionization. TrOC concentrations in liquid samples (500 mL each) were extracted using 6 mL 200 mg Oasis HLB cartridges (Waters, Milford, MA, USA). First, the cartridges were preconditioned with 7 mL dichloromethane and methanol mixture (1:1 v/v), 7 mL methanol, followed by 7 mL reagent water (synthetic feed wastewater excluding TrOCs). The samples were acidified to pH 2-3 and loaded onto the cartridges at a flow rate of 1-5 mL/min. Then, the cartridges were rinsed with 20 mL Milli-Q water and dried in a stream of nitrogen gas for 30 min. The extracted TrOCs were eluted from the cartridge using 7 mL of methanol followed by dichloromethane and methanol mixture (1:1 v/v) at a flow rate of 1-5 mL/min. Then the eluents were evaporated in a water bath (40 °C) under a gentle stream of nitrogen. The extracts were dissolved in 200 µL methanol which contained 5 µg bisphenol A-d₁₆, transferred into 1.5 mL vials, and further evaporated under a gentle stream of nitrogen. Finally, the extracts were derivatized by adding 100 µL of N,O-Bis(trimethylsilyl)trifluoroacetamide (1% trimethylchlorosilane) and pyridine (dried with KOH solid), then heated in a heating block (60–70 °C) for 30 min. The derivatives

were cooled to room temperature and analysed using a GC–MS QP5000 (Shimadzu, Japan) unit equipped with an AOC20i autosampler and a Phenomenex Zebron ZB-5 (5% diphenyl–95% dimethylpolysiloxane) capillary column (30 m × 0.25 mm ID, $d_f = 0.25 \mu\text{m}$). The limit of detection of the selected TrOCs by this analytical method was 20 ng/L or lower (Hai et al., 2011b).

3. Results and discussion

3.1 Biological Performance

Basic performance of both the thermophilic bioreactor and MDBR system were assessed in terms of the distillate flux, distillate quality (i.e., conductivity, TOC, and TN), sludge characteristics (i.e., DO concentration, conductivity, pH, MLSS, and MLVSS) and organics removal (i.e., TOC and TN). The main performance parameters of the system are summarised in Fig. 2. Water flux through the MD membrane decreased from 4 to about 2 L/m².h within the first three days of operation, and after about 10 days of operation it became stable at approximately 1.2±0.2 L/m².h (Fig. 2a). This observed flux profile was consistent with several previous studies (Khaing et al., 2010; Phattaranawik et al., 2008; Phattaranawik et al., 2009). The low water flux observed here could be attributed to the low cross flow velocity (i.e., 9 cm/s; see Section 2.1) in the MD cell used in a laboratory scale system and can be improved by increasing the circulation flow rate. In addition, the stable water flux after 10 days of operation indicated that membrane wetting did not occur in this study, which was also evidenced by the low conductivity (<5 μS/cm) of the distillate (Fig. 2b) during the entire experiment. Changes in hydrophobicity as a result of membrane wetting would lead to lower distillate quality (or an increase in distillate conductivity).

[FIGURE 2]

The mixed liquor salinity (measured by conductivity) increased continuously as the MDBR experiment progressed (Fig. 2b). It is noteworthy that the occasional slight drop in the mixed liquor salinity (Fig. 2b) was due to the collection of supernatant for sampling and replenishment with low salinity makeup wastewater. Salinity build-up during MDBR operation was attributed to the complete rejection of salts by MD (Gryta et al., 2006; Khaing et al., 2010; Phattaranawik et al., 2009). Moreover, there was a small increase in pH of the mixed liquor from 7.6 to 8.2,

which was possibly due to the stripping of carbon dioxide at thermophilic temperatures (Goh et al., 2013a; Suzuki et al., 2002).

TOC removal by the thermophilic bioreactor was stable at 94%, and the supernatant TOC was always below 14 mg/L (Fig. 3a). In addition, TOC removals by thermophilic bioreactor before (Supplementary Data, Fig. S1a) and after MDBR experiment were almost identical. As most of the heterotrophic bacteria are subspecies of the halophilic and halotolerant microbial community, heterotrophic bacteria are more tolerant to salinity increase. Thus, the impact of salinity increase on TOC removal was insignificant (Lay et al., 2010). However, TN removal by the thermophilic bioreactor significantly decreased from relatively stable removal at 51% (prior to MDBR experiment) to almost zero after only about four days of integration of the bioreactor with the MD unit (Fig. 3b and Supplementary Data, Fig. S1b). The poor removal of TN probably resulted from the increase of the mixed liquor salinity which is toxic to nitrifying bacteria (Lay et al., 2010). LaPara and Alleman (1999) also reported that thermophilic aerobic biological treatment is more susceptible to environmental changes than a mesophilic process. A gradual reduction in bioreactor MLVSS concentration was noticed after starting MDBR experiment (Supplementary Data, Fig. S2 and Fig. S3), and this can be attributed to salinity build-up as reported by Alturki et al., (2012) who explored a bioreactor integrated with a forward osmosis unit. This is also consistent with the reported low sludge yield by thermophilic aerobic biological treatment (LaPara and Alleman, 1999).

Although the thermophilic conditions could exert some negative effects on the performance of the bioreactor while salinity builds up, the overall TOC (>99%) and TN (>96%) removals by the hybrid MDBR system were high and independent of the biological stability of the reactor. Distillate TOC and TN concentrations were below 1 mg/L throughout the experiment. These results confirmed that the high performance of MD can offset the negative impact on the biological treatment to produce high quality effluent.

[FIGURE 3]

3.2. *TrOC removal*

[FIGURE 4]

Biological removal in the thermophilic bioreactor and rejection by the MD membrane are the two removal mechanisms of TrOCs in the MDBR system. The individual and total removals of the investigated TrOCs are depicted in Fig. 4. Most TrOCs were moderately or highly removed during thermophilic biological treatment. The results observed showed that salinity build-up did not significantly affect the removal of readily biodegradable TrOCs, and their removal efficiencies were stable over the entire experimental period (Supplementary Data, Fig. S4). The reason might be that biodegradation of these TrOCs was mainly driven by heterotrophic bacteria, which are tolerant to salinity changes (Lay et al., 2010). All TrOCs containing EWGs (Supplementary Data, Fig.S5) in their molecules (i.e., clofibric acid, fenprop, diclofenac, carbamazepine, atrazine, and triclosan) were poorly removed by the biological process in the thermophilic bioreactor, and the removal efficiency was in the range of zero to 53%. Moreover, removal efficiency of carbamazepine, atrazine, and triclosan continually deteriorated with time (Supplementary Data, Fig. S4), exhibiting the detrimental effect of salinity build-up on the removal of recalcitrant TrOCs by the bioreactor alone. It is notable that despite being a hydrophobic compound, triclosan removal by the bioreactor was remarkably low (53%) compared to the values previously reported in case of conventional MBR treatment (Hai et al., 2011b; Miège et al., 2009; Tadkaew et al., 2011). The bioreactor removal efficiency of carbamazepine in this study was also significantly lower than that by a thermophilic MBR operated at similar temperature reported by Hai et al., (2011b) and Wijekoon et al., (2013c). The complexity associated with the dynamic salinity level could modify the microbial community of MDBR due to the salinity selection where nitrification is highly susceptible to the salinity changes (Lay et al., 2010). As carbamazepine is a nitrogenous compound and more likely to be removed by nitrifying bacteria (Hai et al., 2011a; Wijekoon et al., 2013b), it was substantially affected by the salinity increase in the bioreactor. **It is noteworthy that this study was conducted over a short period. In long term operation of the MDBR, the impact of salinity build-up may become less critical due to selective microbial growth and natural adaptation of the halophilic bacteria (Lay et al., 2010).**

All TrOCs investigated in this study were well removed (>95%) by the integrated MDBR system (Fig. 4) despite the impact of salinity build-up on recalcitrant TrOC removal by the bioreactor. TrOC removal by the MD process was investigated in a previous study (Wijekoon et al., 2013c). Although TrOCs with low volatility ($pK_H > 9$) were well rejected, MD alone was not effective for

removal of TrOCs (such as 4-tert-butyl phenol and oxybenzothat) which are moderately volatile ($pK_H < 9$) (Wijekoon et al., 2013c). Thus, the results in the current study imply that MD can complement the biological treatment process very well to achieve high TrOC removal. In addition, the novel MDBR system may offer a high effluent quality independent of the operating conditions of the bioreactor.

3.3. *Fate and distribution of TrOCs during the MDBR process*

[FIGURE 5]

The concentrations of TrOCs and their associated $\log D$ and pK_H values in the solid and liquid phases of the different streams of the MDBR are summarised in Fig. 5. The concentrations of most TrOCs in the aqueous (i.e., feed to the bioreactor, supernatant, and distillate) and solid phases were stable during the experiment. The accumulation of certain TrOCs in the supernatant (Supplementary Data, Fig. S6) may be ascribed to their low biological removal as discussed above. Triclosan was the only TrOC that significantly accumulated in the sludge phase because it is a hydrophobic ($\log D_{pH8} = 4.92$) and recalcitrant compound.

Biodegradation/transformation by the thermophilic bioreactor, adsorption to the sludge phase, and rejection by the MD membrane could all contribute to the removal of TrOCs by the MDBR system. The mass balance of each TrOC was calculated (Equations 1– 4) based on the loading in the feed, supernatant, sludge, and distillate in order to determine the relative contribution between biodegradation/transformation, accumulation in supernatant, adsorption to sludge and volatilisation during MDBR treatment. Volatilisation during the MD process was calculated by taking into account the compound concentration in the distillate. Finally, the percentage of biodegradation/transformation was determined from the difference of measured concentrations in the feed, the bioreactor supernatant, and the distillate (Fig.6).

Percentage biodegradation/transformation, adsorption to sludge, and rejection by MD (accumulation in the supernatant) of TrOCs during MDBR treatment are reported in Fig. 6. Volatilisation to the distillate was insignificant considering the low volatility (as denoted by low Henry's constant or high pK_H) and negligible distillate concentrations of all TrOCs investigated (Fig. 5). The hydrophobicity (measured by $\log D$) and the presence of EDGs and EWGs could also govern the fate and transport of TrOCs. Results revealed that readily biodegradable TrOCs

were mainly removed by biodegradation (>70%). As noted earlier, biodegradation of recalcitrant TrOCs (possessing only EWGs) was considerably low compared to their removal by a conventional MBR process as previously reported (Hai et al., 2011b; Miège et al., 2009; Radjenović et al., 2009; Wijekoon et al., 2013b; Wijekoon et al., 2013c). Biodegradation of triclosan, possessing strong EWG (i.e., chloride) was low (26%) compared to octocrylene (74%), which possesses weak EWGs (i.e., cyano).

TrOC rejection by MD was the main removal mechanism of recalcitrant compounds by the MDBR hybrid system. MD rejection accounted for the greater portion of overall removal of six recalcitrant TrOCs, including triclosan (42%), fenoprop (64%), atrazine (68%), clofibric acid (71%), diclofenac (75%), and carbamazepine (94%).

Accumulation in sludge greatly contributed to the aqueous phase removal of hydrophobic recalcitrant compounds (i.e., triclosan and octocrylene). Data from this study reveals that accumulation in sludge was governed more by the strength of the EWG than the hydrophobicity of the compound. For example, sludge adsorption of triclosan, which is less hydrophobic ($\log D_{\text{pH } 8} = 4.92$) but possesses stronger EWGs (i.e., chloro), was higher (33%) compared to that of octocrylene (22%), which is more hydrophobic ($\log D_{\text{pH } 8} = 6.89$) but possesses weaker EWGs (i.e., cyano).

[FIGURE 6]

4. Conclusion

The removal of 25 TrOCs by a novel hybrid MDBR system was investigated. While most TrOCs were well removed by biological processes in the thermophilic bioreactor, compounds containing EWG groups in their molecular structure were recalcitrant to biological degradation. Salinity build-up occurred during MDBR operation which negatively affected the performance of the biological processes in the thermophilic bioreactor, lowering the removal of total nitrogen and recalcitrant TrOCs. However, the overall performance of the MDBR system with respect to the removal of all 25 TrOCs, TOC, and TN was high and independent of the performance of the bioreactor.

5. Acknowledgement

This research was supported under Australian Research Council's *Discovery Projects* funding scheme (project DP140103864). The authors would like to thank the University of Wollongong for the PhD scholarship support to Kaushalya C. Wijekoon.

References

- [1] Achilli, A., Cath, T.Y., Marchand, E.A., Childress, A.E. 2009. The forward osmosis membrane bioreactor: A low fouling alternative to MBR processes. *Desalination*, 239, 10-21.
- [2] Alturki, A., McDonald, J., Khan, S.J., Hai, F.I., Price, W.E., Nghiem, L.D. 2012. Performance of a novel osmotic membrane bioreactor (OMBR) system: Flux stability and removal of trace organics. *Bioresour. Technol.*, 113, 201-206.
- [3] Alturki, A.A., Tadkaew, N., McDonald, J.A., Khan, S.J., Price, W.E., Nghiem, L.D. 2010. Combining MBR and NF/RO membrane filtration for the removal of trace organics in indirect potable water reuse applications. *J Memb Sci*, 365, 206-215.
- [4] Boonyaroj, V., Chiemchaisri, C., Chiemchaisri, W., Theeparaksapan, S., Yamamoto, K. 2012. Toxic organic micro-pollutants removal mechanisms in long-term operated membrane bioreactor treating municipal solid waste leachate. *Bioresour. Technol.*, 113, 174-180.
- [5] Choi, J.-H., Dockko, S., Fukushi, K., Yamamoto, K. 2002. A novel application of a submerged nanofiltration membrane bioreactor (NF MBR) for wastewater treatment. *Desalination*, 146, 413-420.
- [6] Clara, M., Strenn, B., Gans, O., Martinez, E., Kreuzinger, N., Kroiss, H. 2005. Removal of selected pharmaceuticals, fragrances and endocrine disrupting compounds in a membrane bioreactor and conventional wastewater treatment plants. *Water Res.*, 39, 4797-4807.
- [7] Curcio, E., Drioli, E. 2005. Membrane distillation and related operations—A review. *Separation & Purification Reviews*, 34, 35-86.
- [8] Goh, S., Zhang, J., Liu, Y., Fane, A.G. 2013a. Fouling and wetting in membrane distillation (MD) and MD-bioreactor (MDBR) for wastewater reclamation. *Desalination*, 323, 39-47.
- [9] Goh, S., Zhang, Q., Zhang, J., McDougald, D., Krantz, W.B., Liu, Y., Fane, A.G. 2013b. Impact of a biofouling layer on the vapor pressure driving force and performance of a membrane distillation process. *J Memb Sci*, 438, 140-152.
- [10] Gryta, M., Tomaszewska, M., Karakulski, K. 2006. Wastewater treatment by membrane distillation. *Desalination*, 198, 67-73.
- [11] Hai, F.I., Li, X., Price, W.E., Nghiem, L.D. 2011a. Removal of carbamazepine and sulfamethoxazole by MBR under anoxic and aerobic conditions. *Bioresour. Technol.*, 102, 10386-10390.

- [12] Hai, F.I., Tessmer, K., Nguyen, L.N., Kang, J., Price, W.E., Nghiem, L.D. 2011b. Removal of micropollutants by membrane bioreactor under temperature variation. *J Memb Sci*, 383, 144-151.
- [13] Hancock, N.T., Xu, P., Heil, D.M., Bellona, C., Cath, T.Y. 2011. Comprehensive Bench- and Pilot-Scale Investigation of Trace Organic Compounds Rejection by Forward Osmosis. *Environ Sci Technol*, 45, 8483-8490.
- [14] Hancock, N.T., Xu, P., Roby, M.J., Gomez, J.D., Cath, T.Y. 2013. Towards direct potable reuse with forward osmosis: Technical assessment of long-term process performance at the pilot scale. *J Memb Sci*, 445, 34-46.
- [15] Khaing, T.-H., Li, J., Li, Y., Wai, N., Wong, F.-s. 2010. Feasibility study on petrochemical wastewater treatment and reuse using a novel submerged membrane distillation bioreactor. *Separation and Purification Technology*, 74, 138-143.
- [16] LaPara, T.M., Alleman, J.E. 1999. Thermophilic aerobic biological wastewater treatment. *Water Res.*, 33, 895-908.
- [17] Lay, W.C.L., Liu, Y., Fane, A.G. 2010. Impacts of salinity on the performance of high retention membrane bioreactors for water reclamation: A review. *Water Res.*, 44, 21-40.
- [18] Melin, T., Jefferson, B., Bixio, D., Thoeye, C., De Wilde, W., De Koning, J., van der Graaf, J., Wintgens, T. 2006. Membrane bioreactor technology for wastewater treatment and reuse. *Desalination*, 187, 271-282.
- [19] Miège, C., Choubert, J.M., Ribeiro, L., Eusèbe, M., Coquery, M. 2009. Fate of pharmaceuticals and personal care products in wastewater treatment plants - Conception of a database and first results. *Environ. Pollut.*, 157, 1721-1726.
- [20] Nghiem, L.D., Cath, T. 2011. A scaling mitigation approach during direct contact membrane distillation. *Separation and Purification Technology*, 80, 315-322.
- [21] Nguyen, L.N., Hai, F.I., Kang, J., Nghiem, L.D., Price, W.E., Guo, W., Ngo, H.H., Tung, K.-L. 2013a. Comparison between sequential and simultaneous application of activated carbon with membrane bioreactor for trace organic contaminant removal. *Bioresour. Technol.*, 130, 412-417.
- [22] Nguyen, L.N., Hai, F.I., Kang, J., Price, W.E., Nghiem, L.D. 2013b. Removal of emerging trace organic contaminants by MBR-based hybrid treatment processes. *International Biodeterioration & Biodegradation*, 85, 474-482.
- [23] Phattaranawik, J., Fane, A.G., Pasquier, A.C.S., Bing, W. 2008. A novel membrane bioreactor based on membrane distillation. *Desalination*, 223, 386-395.
- [24] Phattaranawik, J., Fane, A.G., Pasquier, A.C.S., Bing, W., Wong, F.S. 2009. Experimental Study and Design of a submerged membrane distillation bioreactor: Research article. *Chemical Engineering Technology*, 32, 38-44.
- [25] Radjenović, J., Petrović, M., Barceló, D. 2009. Fate and distribution of pharmaceuticals in wastewater and sewage sludge of the conventional activated sludge (CAS) and advanced membrane bioreactor (MBR) treatment. *Water Res.*, 43, 831-841.

- [26] Schwarzenbach, R.P., Escher, B.I., Fenner, K., Hofstetter, T.B., Johnson, C.A., von Gunten, U., Wehrli, B. 2006. The Challenge of Micropollutants in Aquatic Systems. *Science*, 313, 1072-1077.
- [27] Shannon, M.A., Bohn, P.W., Elimelech, M., Georgiadis, J.G., Marinas, B.J., Mayes, A.M. 2008. Science and technology for water purification in the coming decades. *Nature*, 452, 301-310.
- [28] Suzuki, K., Tanaka, Y., Osada, T., Waki, M. 2002. Removal of phosphate, magnesium and calcium from swine wastewater through crystallization enhanced by aeration. *Water Res.*, 36, 2991-2998.
- [29] Tadkaew, N., Hai, F.I., McDonald, J.A., Khan, S.J., Nghiem, L.D. 2011. Removal of trace organics by MBR treatment: The role of molecular properties. *Water Res.*, 45, 2439-2451.
- [30] Tran, N.H., Urase, T., Ngo, H.H., Hu, J., Ong, S.L. 2013a. Insight into metabolic and cometabolic activities of autotrophic and heterotrophic microorganisms in the biodegradation of emerging trace organic contaminants. *Bioresour. Technol.*, 146, 721-731.
- [31] Tran, N.H., Urase, T., Ta, T.T. 2013b. A preliminary study on the occurrence of pharmaceutically active compounds in hospital wastewater and surface water in Hanoi, Vietnam. *CLEAN – Soil, Air, Water* doi:10.1002/clen.201300021.
- [32] Wijekoon, K.C., Fujioka, T., McDonald, J.A., Khan, S.J., Hai, F.I., Price, W.E., Nghiem, L.D. 2013a. Removal of N-nitrosamines by an aerobic membrane bioreactor. *Bioresour. Technol.*, 141, 41-45.
- [33] Wijekoon, K.C., Hai, F.I., Kang, J., Price, W.E., Guo, W., Ngo, H.H., Nghiem, L.D. 2013b. The fate of pharmaceuticals, steroid hormones, phytoestrogens, UV-filters and pesticides during MBR treatment. *Bioresour. Technol.*, 144, 247-254.
- [34] Wijekoon, K.C., Hai, F.I., Kang, J., Price, W.E., Cath Tzahi, Nghiem, L.D. 2013c. Rejection and fate of trace organic compounds (TrOCs) during membrane distillation. *J Memb Sci* doi.org/10.1016/j.memsci.2013.12.002i.
- [35] Zhao, J.-L., Ying, G.-G., Liu, Y.-S., Chen, F., Yang, J.-F., Wang, L., Yang, X.-B., Stauber, J.L., Warne, M.S.J. 2010. Occurrence and a screening-level risk assessment of human pharmaceuticals in the Pearl River system, South China. *Environ. Toxicol. Chem.*, 29, 1377-1384.

LIST OF FIGURES AND TABLES CAPTIONS

Fig.1. Schematic diagram of the novel MDBR experimental system.

Fig. 2. (a) Distillate flux profile (b) Conductivity and pH variation of mixed liquor/distillate of MDBR hybrid system over the experimental period: The temperature difference across the MD cell was 24 °C with feed temperature of 38 °C immediately before the cell and distillate temperatures of 14 °C immediately after the cell. The conductivity and pH of feed were $320 \pm 17 \mu\text{S/cm}$ and 7.5 ± 0.1 , respectively. The DO concentration and temperature of bioreactor sludge were $2.8 \pm 0.5 \text{ mg/L}$ and 40 °C, respectively.

Fig. 3. The variation of TOC and TN removal of the MDBR hybrid system. The stable flux was $1.2 \pm 0.2 \text{ L/m}^2\cdot\text{h}$. Operating conditions were as stated in the caption of Fig. 2.

Fig. 4. TrOC removal by the hybrid MDBR system. Distillate flux was stable at $1.2 \pm 0.2 \text{ L/m}^2\cdot\text{h}$. The DO concentration and temperature of the bioreactor sludge were $2.8 \pm 0.5 \text{ mg/L}$ and 40 °C, respectively. Removal efficiency represents the average value of duplicate samples taken once a week for five weeks. Operating conditions are stated in the caption of Fig. 2.

Fig. 5. Concentration of the selected TrOC in (a) the aqueous phase and (b) the sludge phase of the MDBR hybrid system. Operating conditions are given in Fig. 4. Error bars represent the standard deviation of duplicate samples taken once a week for five weeks. Error bars of sludge data represent the standard deviation of duplicate samples taken once a week for four weeks.

Fig. 6. Fate of the selected TrOCs during MDBR treatment.

LIST OF FIGURES

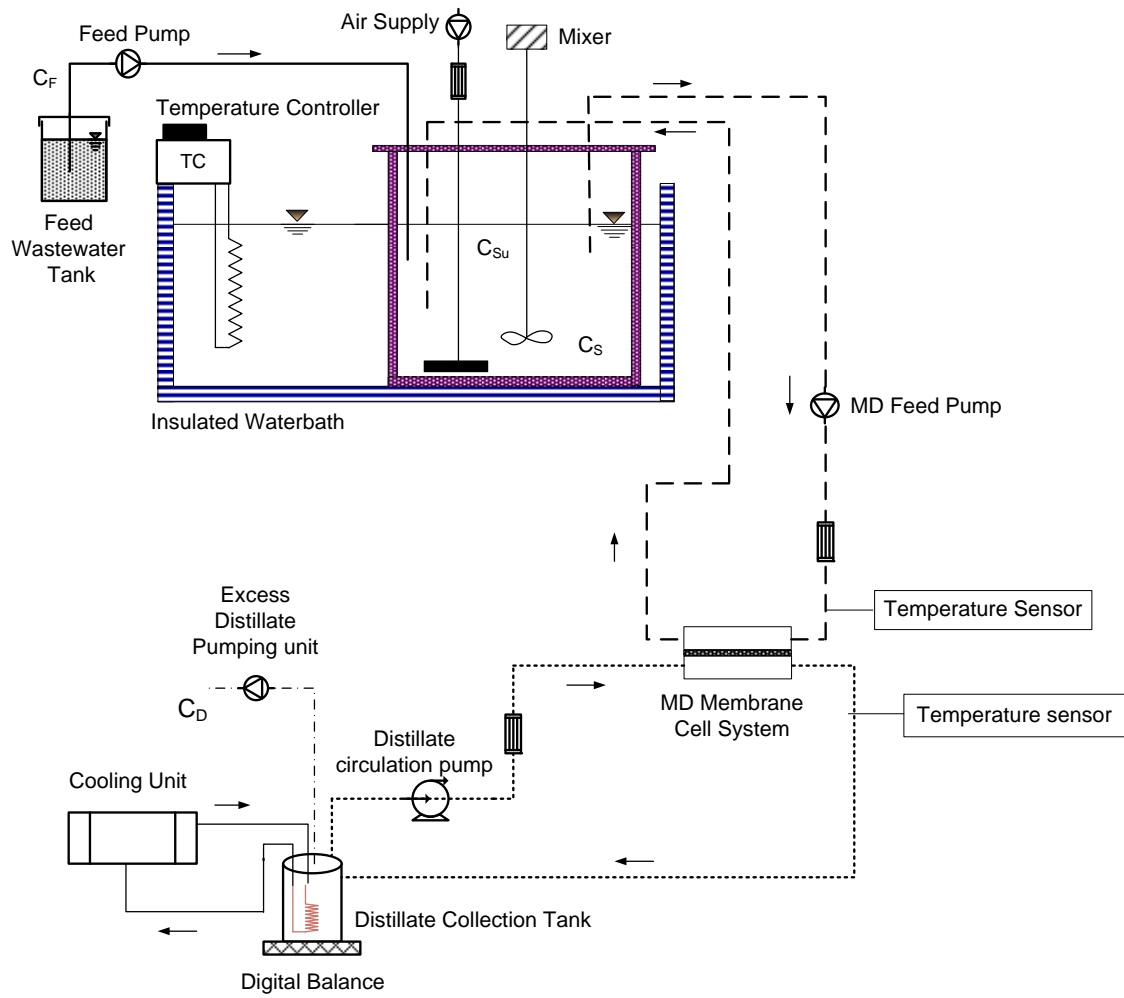

Fig. 1

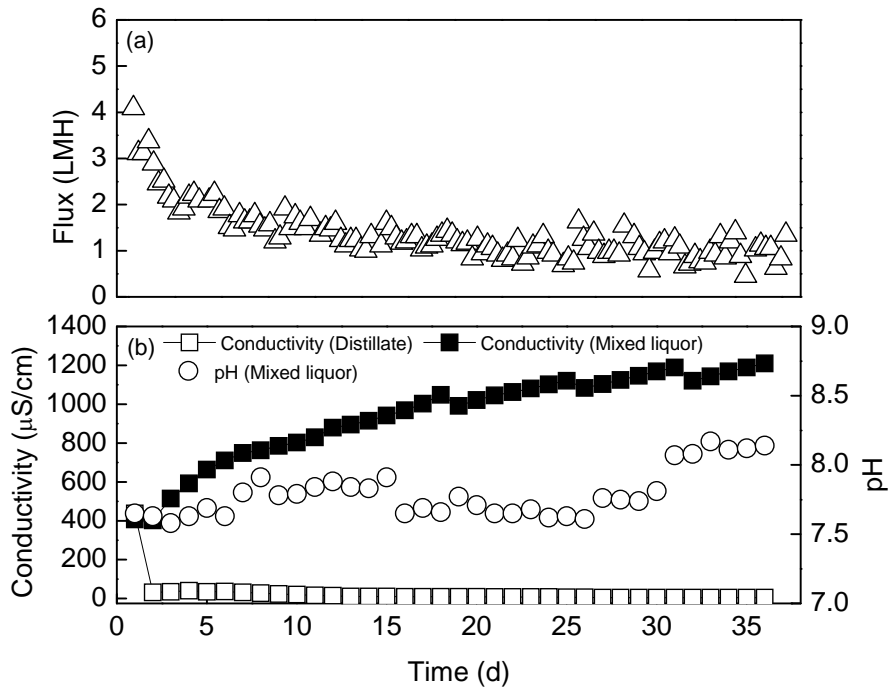

Fig. 2

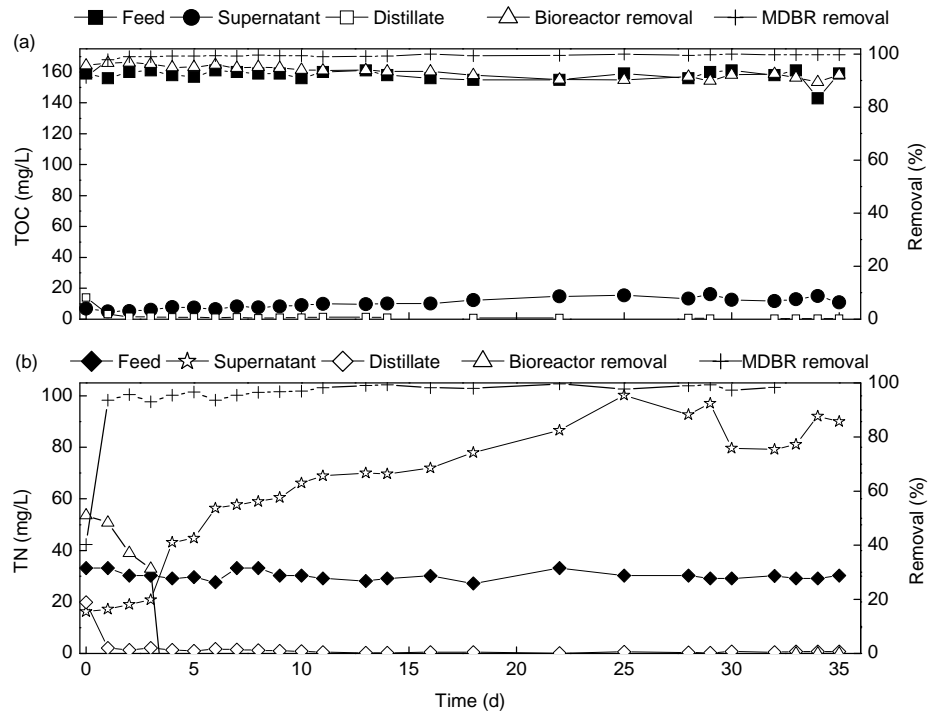

Fig. 3

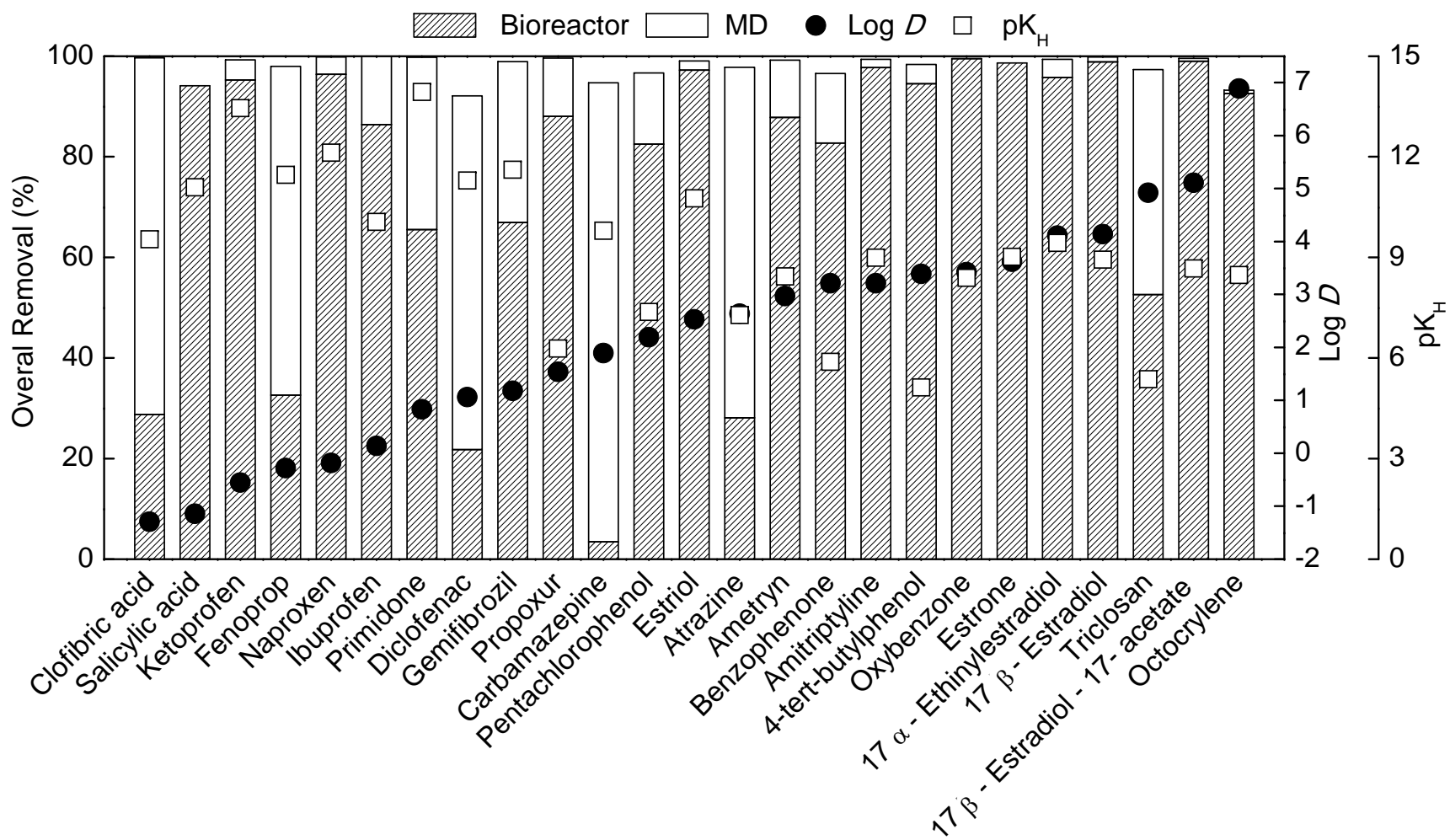

Fig. 4

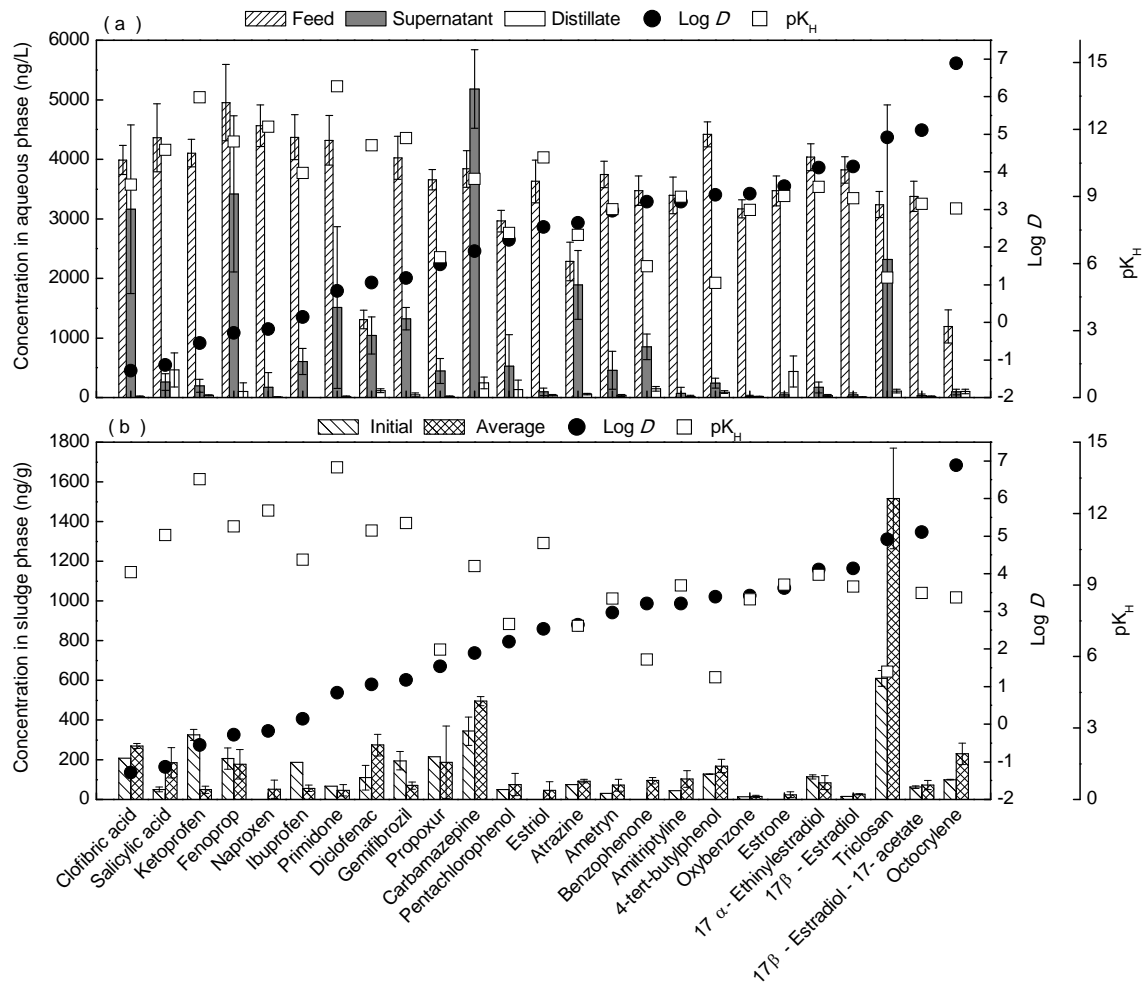

Fig. 5

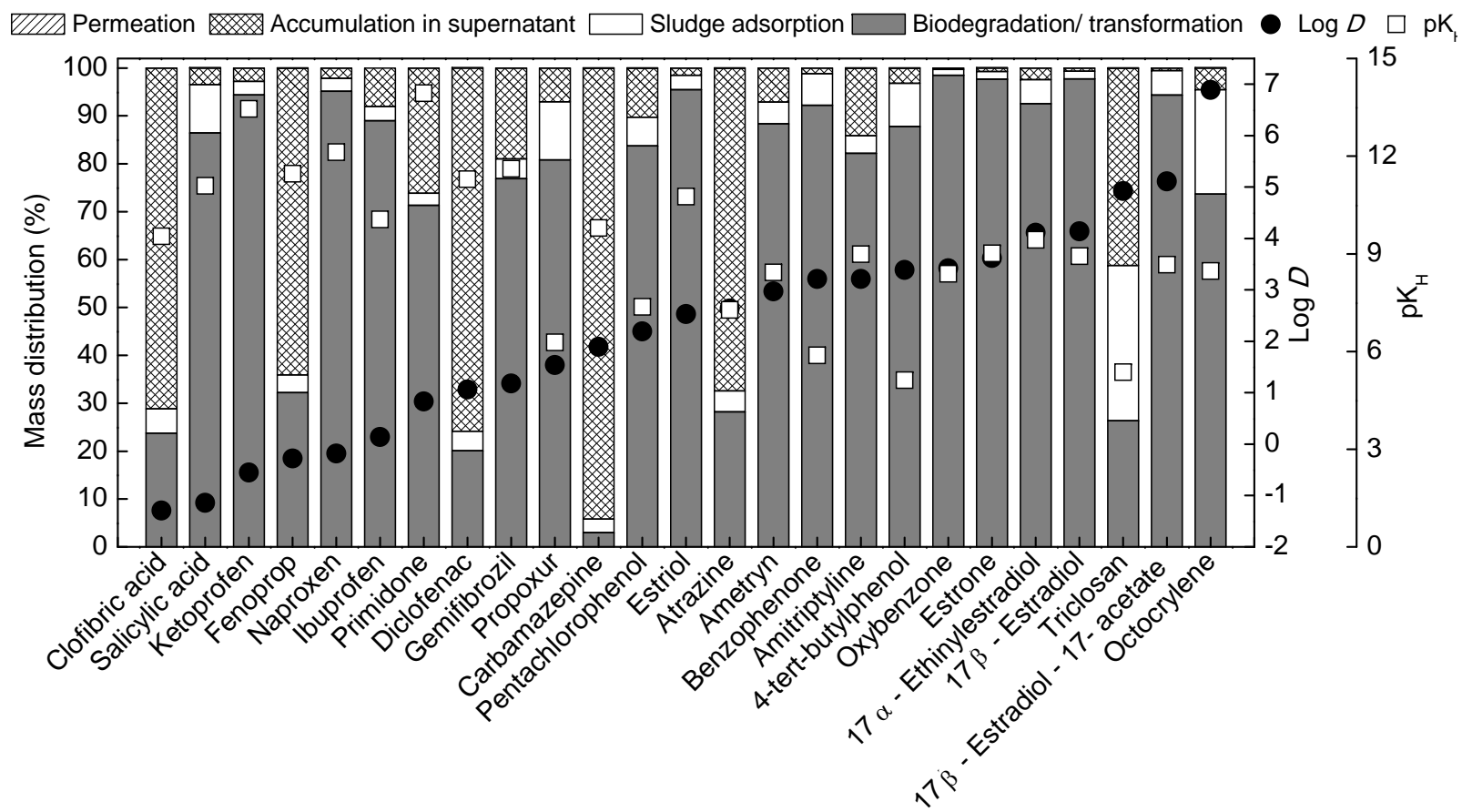

Fig. 6

LIST OF TABLES

Table 1 Physicochemical properties of the selected compounds

Compound	Molecular formula	Molecular Weight (g/mol)	Log <i>D</i> at pH 8	pK _H at pH 8
Clofibric acid	C ₁₀ H ₁₁ ClO ₃	214.64	-1.29	9.54
Salicylic acid	C ₇ H ₆ O ₃	138.12	-1.14	11.09
Ketoprofen	C ₁₆ H ₁₄ O ₃	254.30	-0.55	13.45
Fenoprop	C ₉ H ₇ Cl ₃ O ₃	269.51	-0.28	11.46
Naproxen	C ₁₄ H ₁₄ O ₃	230.30	-0.18	12.12
Ibuprofen	C ₁₃ H ₁₈ O ₂	206.30	0.14	10.06
Primidone	C ₁₂ H ₁₄ N ₂ O ₂	218.25	0.83	13.93
Diclofenac	C ₁₄ H ₁₁ Cl ₂ NO ₂	296.15	1.06	11.29
Gemfibrozil	C ₁₅ H ₂₂ O ₃	250.30	1.18	11.61
Propoxur	C ₁₁ H ₁₅ NO ₃	209.24	1.54	6.28
Carbamazepine	C ₁₅ H ₁₂ N ₂ O	236.27	1.89	9.79
Pentachlorophenol	C ₆ HCl ₅ O	266.38	2.19	7.37
Estriol	C ₁₈ H ₂₄ O ₃	288.40	2.53	10.76
Atrazine	C ₈ H ₁₄ ClN ₅	215.68	2.64	7.28
Ametryn	C ₉ H ₁₇ N ₅ S	227.33	2.97	8.43
Benzophenone	C ₁₃ H ₁₀ O	182.22	3.21	5.88
Amitriptyline	C ₂₀ H ₂₃ N	277.40	3.21	8.99
4 – tert – butyphenol	(CH ₃) ₃ CC ₆ H ₄ OH	150.22	3.39	5.12
Oxybenzone	C ₁₄ H ₁₂ O ₃	228.24	3.42	8.39
Estrone	C ₁₈ H ₂₂ O ₂	270.36	3.62	9.20
17 α – Ethinylestradiol	C ₂₀ H ₂₄ O ₂	296.48	4.11	9.02
17 β – Estradiol	C ₁₈ H ₂₄ O ₂	272.38	4.14	8.67
Triclosan	C ₁₂ H ₇ Cl ₃ O ₂	287.50	4.92	5.37
17 β – Estrodiol – 17 – acetate	C ₂₀ H ₂₆ O ₃	314.42	5.11	8.67
Octocrylene	C ₂₄ H ₂₇ N	361.48	6.89	8.47

Note: Henry's law constant (*H*) values were calculated as: Henry's law constant at 25 °C (atm.m³/mol) = Vapour pressure × molecular weight / water solubility. The pK_H value is defined as pK_H = -log₁₀*H*. Molecular formulae, molecular weight, log *D*, vapour pressure and water solubility values were from SciFinder Scholar.

**A novel membrane distillation – thermophilic bioreactor system:
Biological stability and trace organic compound removal**

Revised Supplementary Data

Bioresource Technology

Feb 2014

Kaushalya C. Wijekoon ^a, Faisal I. Hai ^a, Jinguo Kang ^b, William E. Price ^b, Wenshan Guo ^c,
Hao H. Ngo ^c, Tzahi Y. Cath ^d and Long D. Nghiem ^{a,*}

^a Strategic Water Infrastructure Laboratory, School of Civil Mining and Environmental
Engineering, University of Wollongong, Wollongong, NSW 2522, Australia

^b Strategic Water Infrastructure Laboratory, School of Chemistry
University of Wollongong, Wollongong, NSW 2522, Australia

^c Centre for Technologies in Water and Wastewater,
School of Civil and Environmental Engineering, University of Technology Sydney, Sydney
NSW 2007, Australia

^d Advanced Water Technology Center (AQWATEC), Department of Civil and Environmental
Engineering, Colorado School of Mines, Golden, CO 80401, USA

* Corresponding author: Long Duc Nghiem, Email: longn@uow.edu.au; Ph +61 2 4221 4590

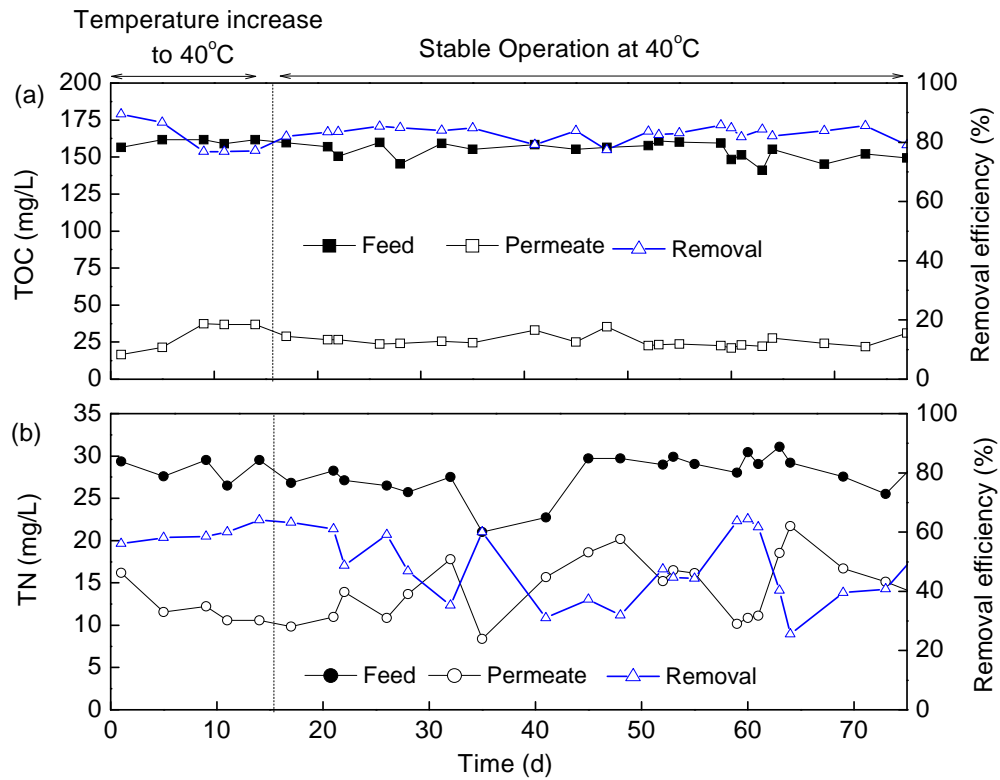

Fig.S1: TOC and TN removal of thermophilic bioreactor during acclimatisation period (i.e., prior to MBR experiment). Bioreactor was acclimatised (increase temperature to 40 °C and stable operation) at 40 °C by operating the system in an MBR mode using a ceramic microfiltration membrane module.

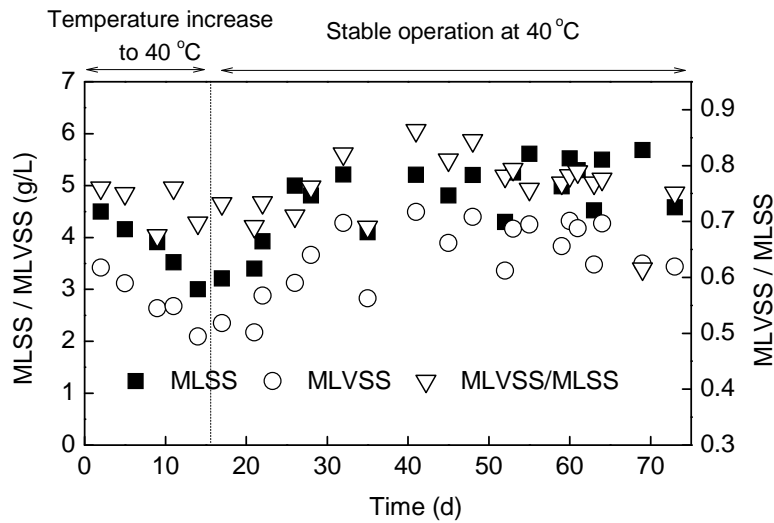

Fig.S2: Variation of sludge concentration in the thermophilic bioreactor during acclimatisation period.

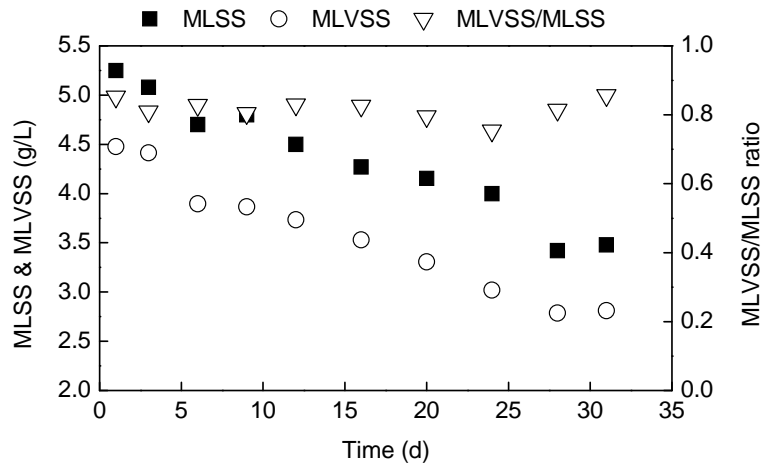

Fig.S3. Variation of sludge concentration in the thermophilic bio reactor during MDBR experiment

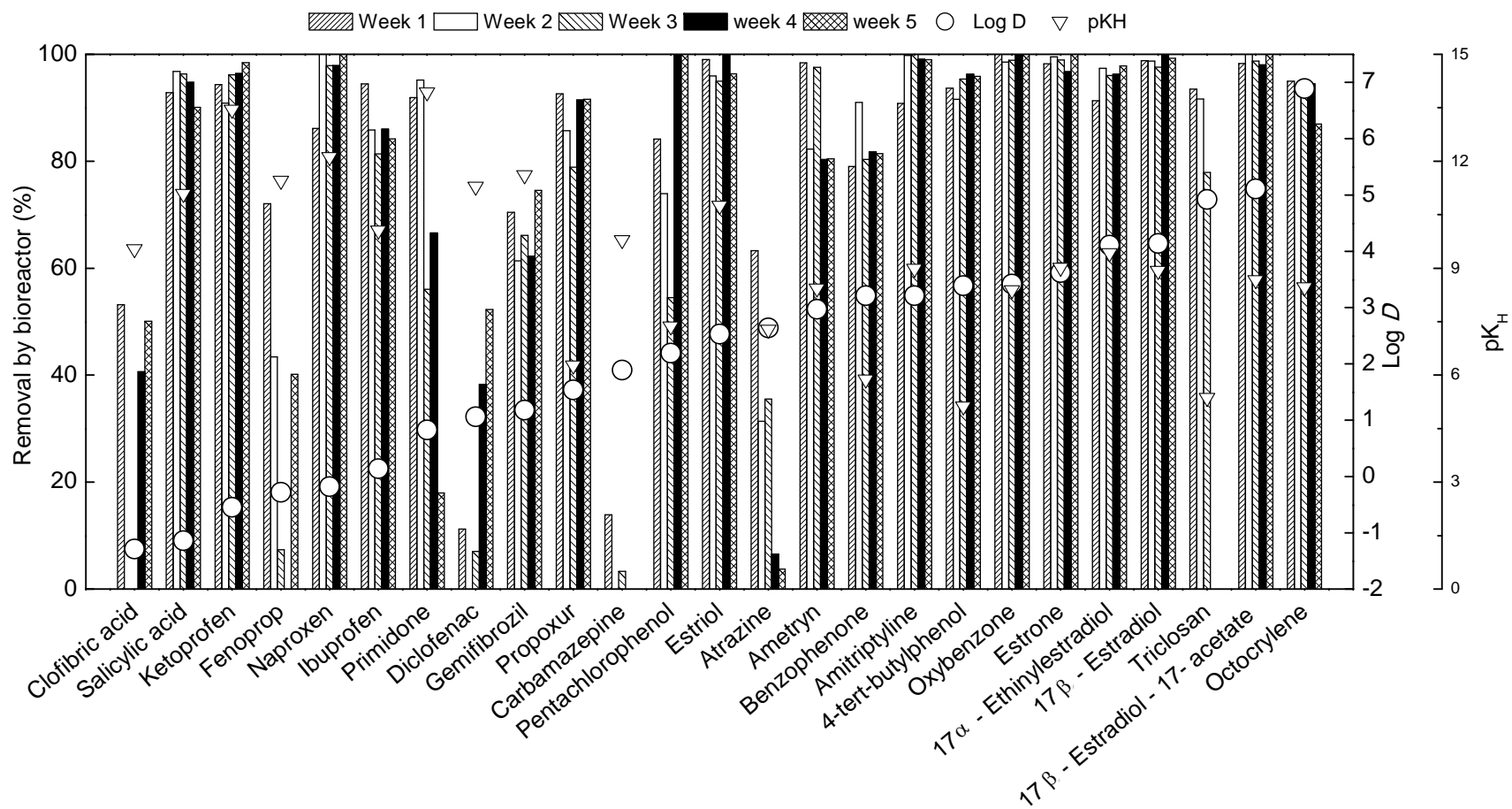
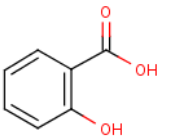
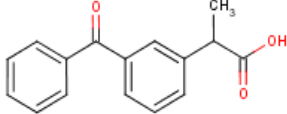
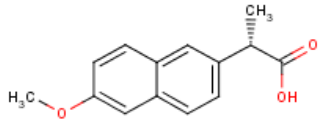
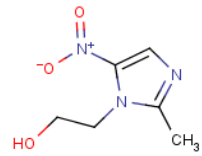
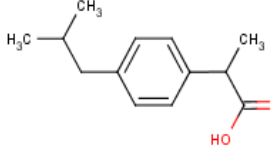
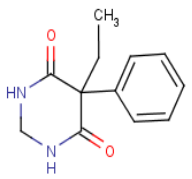
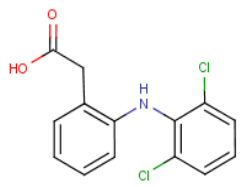
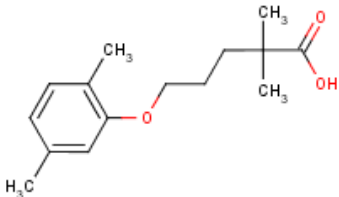
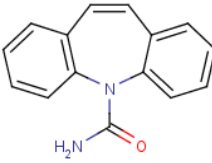
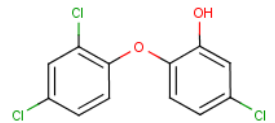
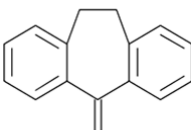
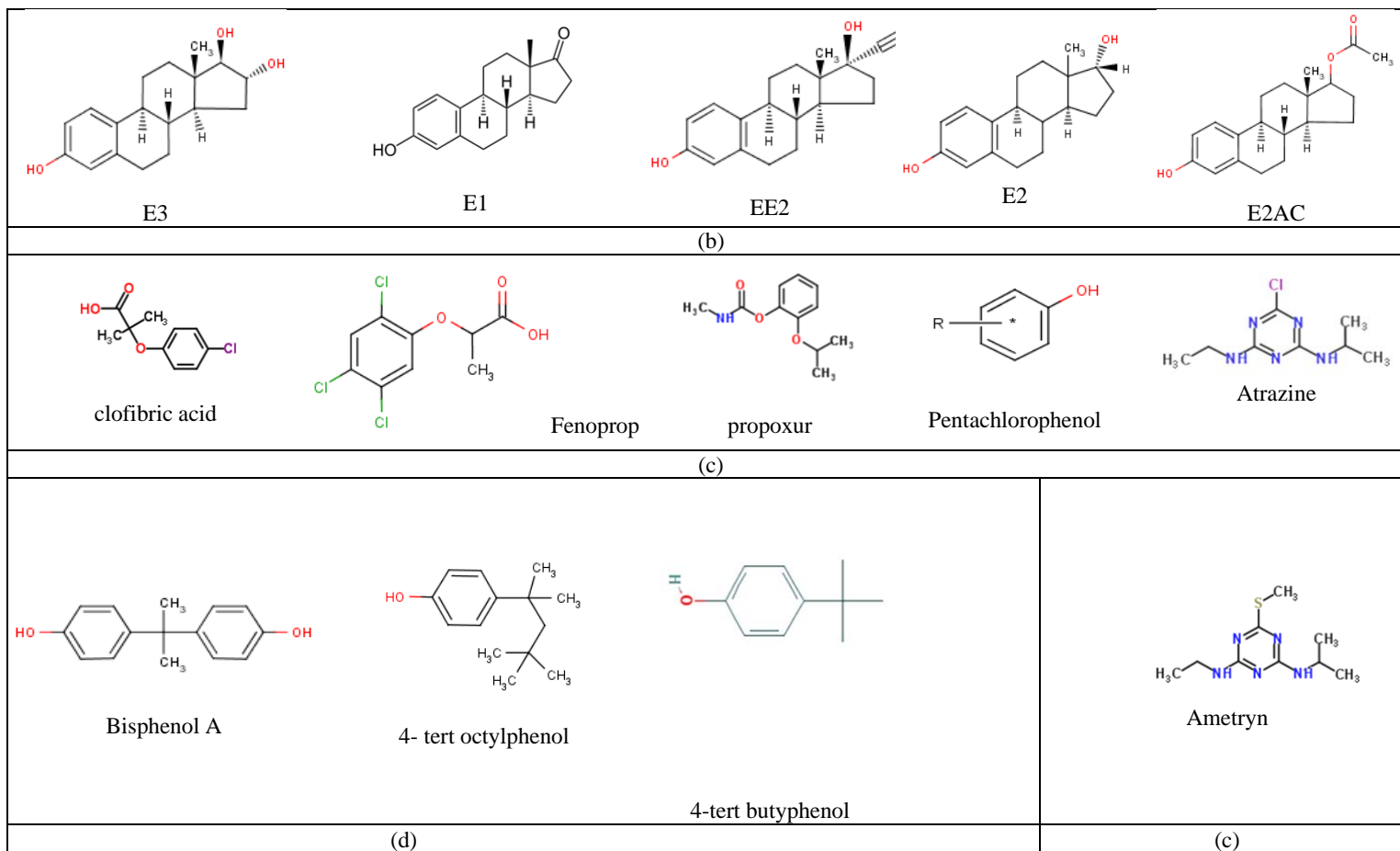

Fig. S4. TrOC removal by bioreactor (R_1) as a function of time during MDBR treatment. $R_1 = 100 \times (1 - C_{Su}/C_F)$ where C_F and C_{Su} , are concentration of the specific compound in the bioreactor feed and bioreactor supernatant.

Electrone Withdrawing group (EWGs)	Electrone donating groups (EDGs)
$-X, -\overset{\text{O}}{\parallel}{\text{C}}-\text{NR}_2, -\overset{\text{O}}{\parallel}{\text{C}}-\text{OH} \quad \text{C}\equiv\text{N}$ <div style="display: flex; justify-content: space-around; align-items: flex-start;"> <div style="text-align: center;">  <p>Salicylic acid</p> </div> <div style="text-align: center;">  <p>Ketoprofen</p> </div> <div style="text-align: center;">  <p>Naproxen</p> </div> <div style="text-align: center;">  <p>Metronidazole</p> </div> <div style="text-align: center;">  <p>Ibuprofen</p> </div> </div> <div style="display: flex; justify-content: space-around; align-items: flex-start; margin-top: 20px;"> <div style="text-align: center;">  <p>Primidone</p> </div> <div style="text-align: center;">  <p>Diclofenac</p> </div> <div style="text-align: center;">  <p>Gemfibrozil</p> </div> <div style="text-align: center;">  <p>Carbamazepine</p> </div> <div style="text-align: center;">  <p>Triclosan</p> </div> </div> <div style="text-align: center; margin-top: 20px;">  <p>CH-CH₂-CH₂-NMe₂ Amitriptyline</p> </div>	
(a)	



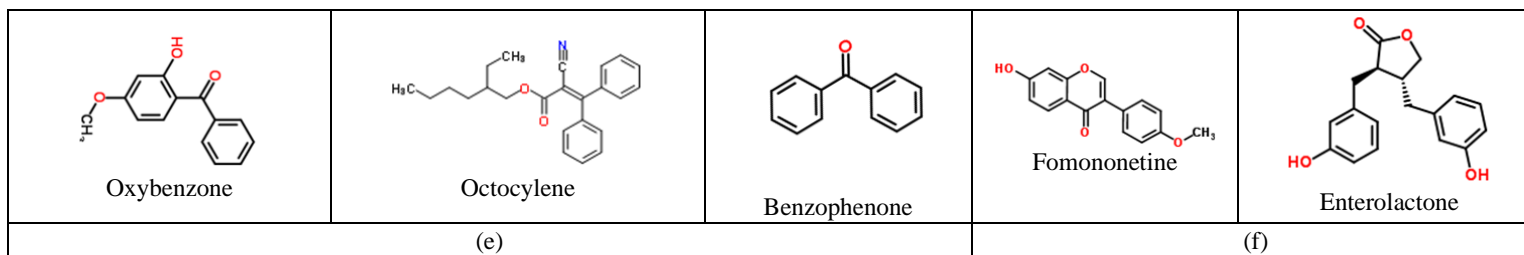

Figure S5: (a) Chemical structures of the selected trace organic contaminants (a) PhACs (b) steroid hormones (c) pesticides (d) industrial chemicals (e) UV filters (f) phytoestrogens

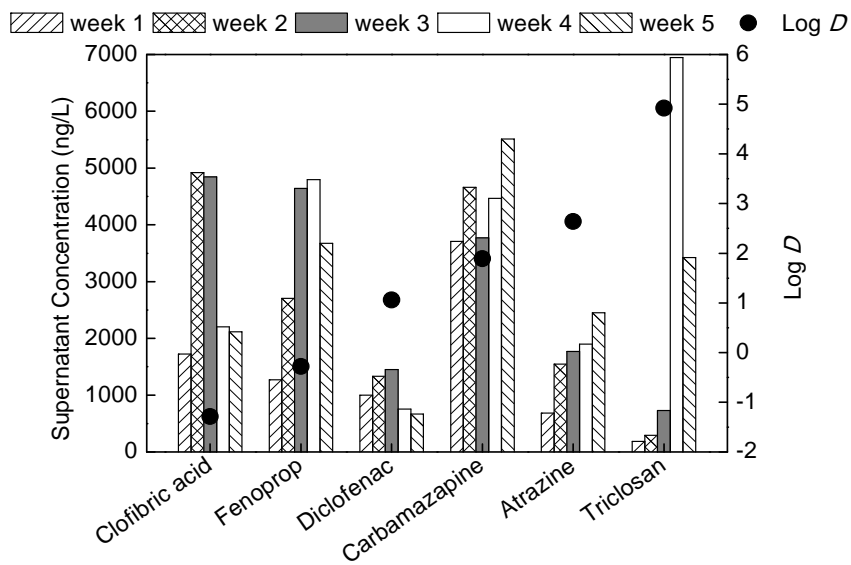

Fig.S6. Variation in the supernatant concentration of recalcitrant TrOCs with time.