



UNIVERSITY
OF WOLLONGONG
AUSTRALIA

University of Wollongong
Research Online

Coal Operators' Conference

Faculty of Engineering and Information Sciences

2013

Hybrid double-skin tubular members for sustainable mining infrastructure

Tao Yu

University of Wollongong

A. M. Remennikov

University of Wollongong, alexrem@uow.edu.au

Publication Details

T. Yu and A. Remennikov, Hybrid double-skin tubular members for sustainable mining infrastructure, 13th Coal Operators' Conference, University of Wollongong, The Australasian Institute of Mining and Metallurgy & Mine Managers Association of Australia, 2013, 429-435.

Research Online is the open access institutional repository for the University of Wollongong. For further information contact the UOW Library: research-pubs@uow.edu.au

HYBRID DOUBLE-SKIN TUBULAR MEMBERS FOR SUSTAINABLE MINING INFRASTRUCTURE

Tao Yu and Alex Remennikov

ABSTRACT: Hybrid FRP-concrete-steel double-skin tubular members (hybrid DSTMs) are a new form of hybrid structural members. A hybrid DSTM consists of an outer tube made of fibre reinforced polymer (FRP) and an inner tube made of steel, with the space between filled with concrete. The two tubes may be concentrically placed to produce a section form more suitable for compression members, or eccentrically placed to produce a section form more suitable for flexural members. In hybrid DSTMs, the three constituent materials are optimally combined to achieve several advantages not available with existing structural members, including their excellent corrosion resistance and energy-dissipation capacity. Hybrid DSTMs are therefore a sustainable alternative to existing structural components, especially for use in structures which are likely to be exposed to a harsh environment. This paper explains the rationale and advantages of this new form of structural members, presents an overview of existing and ongoing research on their structural behaviour and design, and discusses their potential applications in mining infrastructure.

INTRODUCTION

Hybrid FRP-concrete-steel double-skin tubular members (referred to as hybrid DSTMs) (Figure 1) are a new form of hybrid members (Teng, *et al.*, 2007). A hybrid DSTM consists of an outer tube made of fiber-reinforced polymer (FRP) and an inner tube made of steel, with the space between filled with concrete. The two tubes may be concentrically placed (Figures 1a and 1b) to produce a section form more suitable for columns, or eccentrically placed to produce a section form more suitable for beams (Figures 1c and 1d). In hybrid DSTMs, the FRP tube offers mechanical resistance primarily in the hoop direction to confine the concrete and to enhance the shear resistance of the member. Hybrid DSTMs may be constructed in-situ or precast, with the two tubes acting as the stay-in-place form. The sections of the two tubes may be both circular (Figures 1a and 1c), rectangular (Figure 1d), or in another shape; they may also have shapes different from each other (Figure 1b). Shear connectors need to be provided between the steel tube and the concrete, particularly in beams, but are generally not needed for the FRP tube which is normally designed to have only a small longitudinal stiffness.

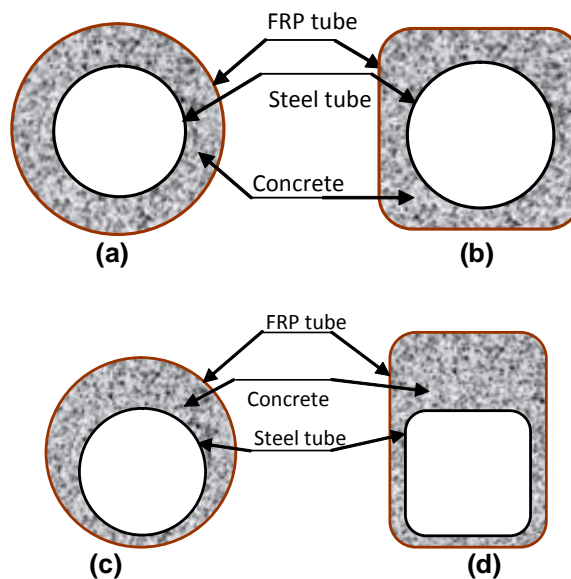

Figure 1 - Typical sections of hybrid DSTMs

The most important advantage of hybrid DSTMs is their excellent corrosion resistance, as the FRP tube is highly resistant to corrosion while the steel tube is protected by the FRP tube and the concrete. The other main advantages of hybrid DSTMs include (1) excellent ductility, as the concrete is well confined by the two tubes and outward local buckling of the steel tube is constrained by the concrete; (2) a high strength/stiffness-to-weight ratio as the inner void largely eliminates the redundant concrete; (3) ease for construction, as the two tubes act as a permanent form for casting concrete, and the presence of the inner steel tube and the concrete allows easy connection to other members. More discussions of the rationale and advantages of hybrid DSTMs are available in Teng, *et al.* (2007).

COMPARISON WITH EXISTING COLUMNS

Comparison with hollow RC columns

Among the existing forms of columns which may be replaced by hybrid DSTMs, hollow reinforced concrete (RC) columns are the most cost-effective. Hollow RC columns have been widely used (Priestley, *et al.*, 1996; Pinto, *et al.*, 2003) because of their high bending resistance coupled with reduced weight (Priestley, *et al.*, 1996). A direct comparison of the construction cost of a hybrid DSTM and that of a hollow RC column, undertaken in 2006 and reported in Teng, *et al.*, (2009), is therefore presented below to demonstrate the cost effectiveness of hybrid DSTMs. The materials and design strengths follow the specifications given by relevant Chinese codes, and particularly the Chinese Code for the Design of Concrete Structures (2002) and the Chinese Technical Code for Infrastructure Application of FRP Composites (2011) (a draft version was referred to at the time of comparison but the relevant provision remained unchanged during the remaining period of preparation). The stress-strain curve for the confined concrete in the DSTM is that proposed in Yu, *et al.* (2010c). The prices of materials adopted in the comparison were the prevailing market rates in mainland China in 2006 when this comparison was conducted and included labour costs. The prices of concrete, steel rebars, steel tubes, and formwork were the prevailing market rates in Guangzhou, China, while the price of RMB20 per kilogram for GFRP tubes was the commercial rate available in mainland China for large orders as normally required by real construction projects. The formwork cost varies with column height and the present comparison was based on the assumption that the column height is 5 m.

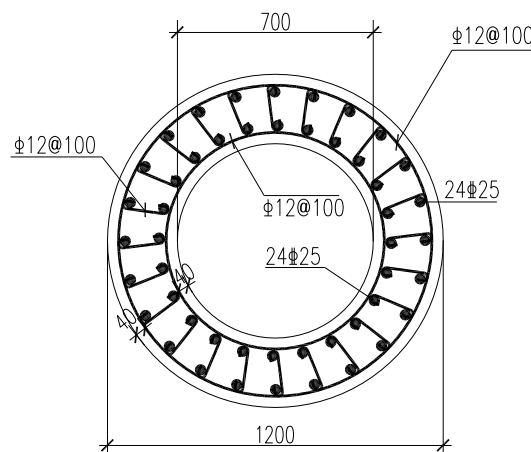

Figure 2 - Cross-section of hollow RC column

Both columns have an outer diameter of 1200 mm and are constructed with grade 40 concrete (i.e. with a design compressive strength of 19.1 MPa according to GB-50010 (2002)). The hollow RC column (Figure 2) is reinforced with 48 ϕ 25 longitudinal steel bars evenly distributed around the circumference and ϕ 12 hoops/ties at 100 mm centres (both with a design strength of 300 MPa) and provided with a concrete cover of 40 mm. The hybrid DSTM has a steel inner tube with an outer diameter D of 700 mm, a thickness t of 10 mm and a design strength of 300 MPa, and an FRP outer tube with a thickness of 4 mm, an elastic modulus of 47.8 GPa in the hoop direction, and a design rupture strain of 0.0114 (an environmental reduction factor was included).

Tables 1 and 2 provide the comparison of costs per meter, which indicates that the hybrid DSTM is a little cheaper. It can thus be concluded that in general, the two types of columns have similar initial construction costs. The axial force-bending moment interaction diagrams of these two columns are compared in Figure 3, which shows that the hybrid DSTM has a larger section capacity than the hollow

RC column when the axial force is reasonably high but the two sections have similar section capacities when bending dominates the behaviour. The curve for the hollow RC column shown in Figure 3 was obtained without considering the confining effect of the steel hoops. However, even if this effect is considered based on the model of Mander, *et al.* (1988) and assuming that the concrete is as effectively confined as in a solid section, the axial load capacity is still below 24 000 kN, which is considerably smaller than that of the hybrid DSTM. This means that the corresponding interaction curve also stays considerably below that of the hybrid DSTM. Besides the load capacity, it should also be noted that hybrid DSTMs possess two important advantages over hollow RC columns: excellent corrosion resistance and excellent seismic resistance.

Table 1 - Construction cost of a hollow RC column per metre

Item	Description	Quantity per metre	Unit Price (RMB)	Cost (RMB)
Concrete	C40	0.75 m ³	327.8 / m ³	245.9
Longitudinal steel bars	48 ϕ 25	183.69 kg	3.8 / kg	698.0
Transverse steel bars	ϕ 12 @100	149.22 kg	3.7 / kg	552.1
Formwork	3-5.8 meters high	5.97 m ²	29.4 / m ²	175.4
Total				1671.4

Table 2 - Construction cost of a hybrid DSTM per metre

Item	Description	Quantity per metre	Unit Price (RMB)	Cost (RMB)
Concrete	C40	0.75 m ³	327.8 / m ³	245.9
Steel tube	D = 700 mm, t = 10 mm	170.22 kg	4.2 / kg	714.9
FRP tube	D = 1200 mm, t = 4 mm	30.09 kg	20 / kg	601.8
Total				1562.6

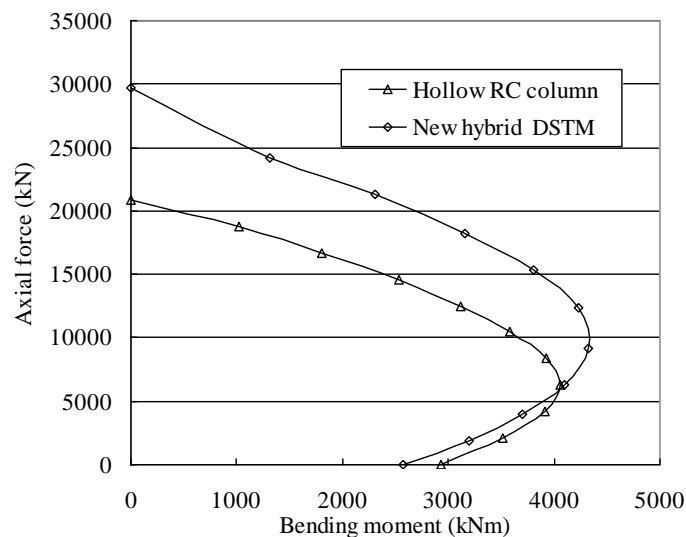

Figure 3 - Axial force-bending moment interaction diagram

Comparison with other columns

Steel-concrete DSTMs with both skins made of steel have been used in construction and have been intensively researched (Zhao and Han, 2006). Such columns have a higher initial construction cost than hollow RC columns for the same structural performance, similar to the well-known fact that concrete-filled steel tubes are more expensive than RC columns (Webb and Peyton, 1990). FRP-concrete DSTMs with two FRP tubes have also been explored (Fam and Rizkalla, 2001) but the use of FRP instead of steel for the inner tube does not lead to any significant advantage but a number of significant disadvantages (e.g. higher cost, reduced stiffness to confine concrete, brittle failure in tension).

Intensive recent research has been conducted on concrete-filled FRP tubes (CFFTs) (i.e. with a solid concrete core) as columns and piles (e.g. Mirmiran and Shahawy, 1997; Fam and Rizkalla, 2001; Yu and Teng, 2011). There have also been some field applications of CFFTs. If excellent durability is the overriding criterion, CFFTs are a possible choice but they are significantly more expensive than RC columns because the FRP tube needs to be thick and to be provided with both longitudinal and hoop fibres. If the FRP tube is not sufficiently thick, premature buckling under compression will considerably compromise its confinement of the concrete core. Even if buckling does not occur, adverse interaction exists between axial compression and hoop tension in such a tube. A hybrid DSTM may be seen as a CFFT with its FRP tube split into an outer FRP tube containing the hoop fibres and an inner FRP tube containing the axial fibres which is then replaced by a much stiffer and much more ductile steel tube. The inner void can also be used for the passing of service ducts. It needs to be emphasised that the FRP tube in a DSTM should generally be quite thin, as its main purpose is to enhance the ductility of the column. Hybrid DSTMs offer many advantages over CFFTs: (a) better confinement of concrete by the FRP tube which contains fibres predominately oriented in the hoop direction; such a tube is mainly subjected to hoop tension and does not buckle under axial straining as has been observed in numerous existing tests of FRP-confined concrete columns; (b) ductile failure in bending as the steel inner tube acts as the longitudinal reinforcement; and (c) savings in cost as the FRP tube is used as a confining device for ductile column response and does not need to be thick.

EXISTING RESEARCH

A large amount of research has been conducted on hybrid DSTMs by the first author and his colleagues. Most of the work undertaken prior to 2007 can be found in Teng, *et al.*, (2007), Yu, *et al.*, (2006), Wong, *et al.*, (2008), and Yu, *et al.*, (2010a, 2010b, 2010c, 2010d). Teng, *et al.*, (2007) explained in detail the rationale for the new member form together with its expected advantages, and presented preliminary experimental results to demonstrate some of the advantages of this new member form, such as excellent ductility and shear resistance. Yu, *et al.*, (2006) presented the results of a systematic experimental study on the flexural behavior of hybrid DSTMs as well as results from a corresponding theoretical model based on the fiber element approach. Yu, *et al.*, (2006) showed that the flexural response of hybrid DSTMs, including their flexural stiffness, cracking load and ultimate load, can be substantially improved by shifting the inner steel tube towards the tension zone or by providing FRP bars as additional longitudinal reinforcement. Wong, *et al.*, (2008) presented a systematic experimental study on the compressive behavior of hybrid DSTMs and compared the performance of hybrid DSTMs with that of FRP-confined solid cylinder/column (FCSC) specimens and FRP-confined hollow cylinder/column (FCHC) specimens; a good understanding of the behaviour of concrete in hybrid DSTMs resulted from this study. Yu, *et al.*, (2010a, b) developed a new plastic-damage model for FRP-confined concrete based on a critical review of the previous D-P type plasticity models. A finite element model incorporating the new plastic-damage model was shown to provide close predictions of the test results of hybrid DSTMs (Yu, *et al.*, 2010b). Based on the available experimental observations and the results from the finite element model, Yu, *et al.*, (2010c) proposed a design-oriented stress-strain model for the confined concrete in hybrid DSTMs subjected to axial compression. Yu, *et al.*, (2010d) presented experimental results on the behaviour of hybrid DSTMs subjected to eccentric compression as well as a so-called "variable confinement model" for the confined concrete to account for the effect of strain gradient on confinement effectiveness. These studies have led to a simple design approach for hybrid DSTMs as columns, and this design approach has recently been adopted by the Chinese Technical Code for Infrastructure Application of FRP Composites (GB50608 2011).

Intensive research on the behaviour and design of hybrid DSTMs is continuing at UoW, in collaboration with The Hong Kong Polytechnic University. The research at UoW has been particularly on the dynamic response of hybrid DSTMs. Preliminary results from a recent experimental study at UoW are briefly presented in the next section.

LATERAL IMPACT TESTS

A total of three hybrid DSTMs were tested under dynamic three-point bending. All specimens had an outer diameter of 152.4 mm, and a clear span of 1300 mm. The steel inner tube all had an outer diameter of 76.1 mm and a thickness of 3.2 mm. The test variables included the thickness of the FRP tube and the end constraint of the beam. These tests were performed using an instrumented drop hammer facility at the High Bay Lab of University of Wollongong (Figure 4). In the tests, a 592 kg mass was released from a height of 1300 mm to directly impact the specimens at the mid-span. A dynamic load cell was mounted on the drop hammer to measure the contact force between the specimen and the drop hammer; a

high-speed camera was used to capture the deflection during the impact process. Figure 5 shows a specimen after test.



Figure 4 - instrumented drop hammer facility



Figure 5 - A specimen after test

A typical impact load-time curve is shown in Figure 6 while a typical mid-span deflection-time curve is shown in Figure 7. The test results showed that hybrid DSTMs possess excellent ductility and are able to sustain very large inelastic rotation without significant reduction in the load capacity. The maximum end rotation was found to be over 10 degrees, which is significantly higher than normally expected for reinforced concrete flexural members (i.e. 4-5 degrees). Hybrid DSTMs therefore has very good potential for resisting large blast and impact loads.

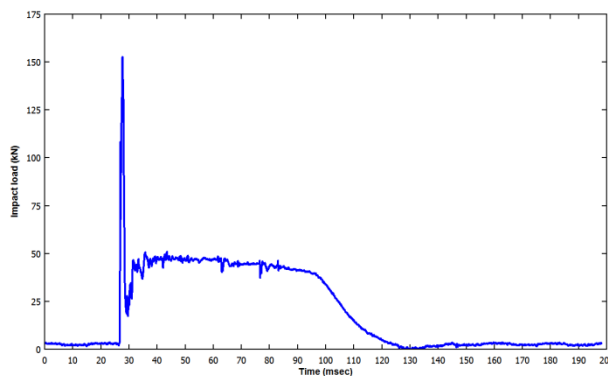

Figure 6 - Typical impact load-time curve

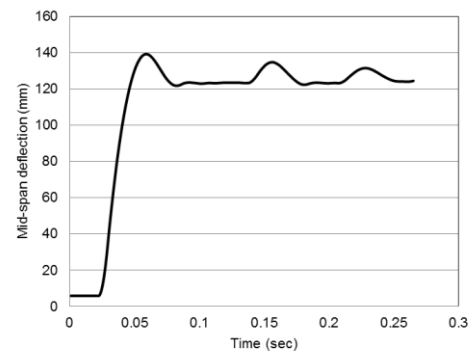

Figure 7 - Typical mid-span deflection-time curve

POTENTIAL PRACTICAL APPLICATION

Because of their excellent corrosion resistance, hybrid DSTMs is most suitable for use in structures which are likely to be exposed to a harsh environment (e.g. coastal structures and underground structures). Hybrid DSTMs can be used as compression members, such as piles, various towers (e.g. wind turbine towers and electricity transmission towers) and other similar structures. In longwall mining, hybrid DSTMs can be used in a roof support system for maingates and/or tailgates. The presence of an inner void in hybrid DSTMs is also an important advantage which can be exploited in mining applications. The inner void can be used for the passing of service ducts or for ventilation, so that hybrid DSTMs serve not only as structural components, but also as functional components.

In practical applications, when the length of DSTMs becomes very large, they can be constructed using a segmental method, which involves the segmental construction of the outer FRP tube and the inner steel tube and the use of the two tubes as the permanent formwork for the in-situ casting of concrete as schematically illustrated in Figure 8. The flanges of the steel tubular segments and the FRP profiles inside the FRP tubular segments serve not only as longitudinal connectors between the segments, but

also as (1) shear connectors between the concrete and the tubes; and (2) stiffeners to both tubes, thus improving the structural performance of hybrid DSTMs.

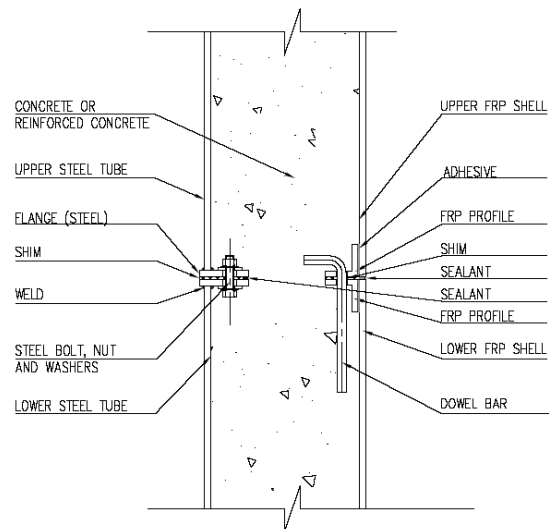

Figure 8 - Segmental construction of hybrid DSTMs

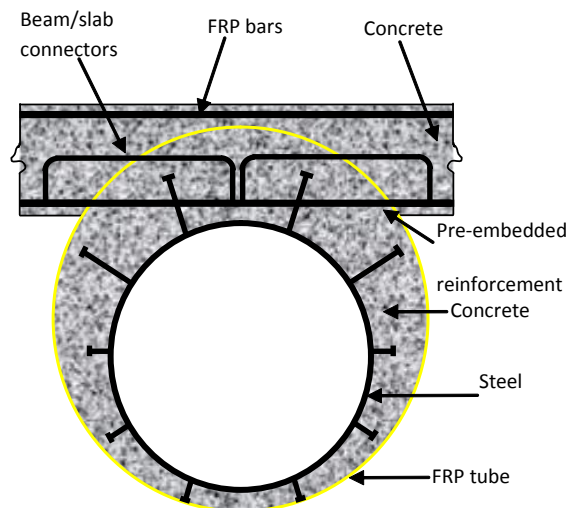

Figure 9 - Hybrid DSTMs/slab units

Hybrid DSTMs can also be used as flexural members in structures exposed to a harsh environment (e.g. underground structures). Hybrid DSTMs can be used alone or be integrated into a concrete slab reinforced with FRP bars to form a durable floor system (Figure 9). In such cases, pre-embedded steel (stainless steel may be used here) reinforcement in the DSTM can be spliced with the bottom layer of FRP bars in the deck using mechanical couplers for beam-slab connection (Figure 9). Additional shear connectors in the form of U-shaped dowels (or other appropriate forms) passing through the FRP tube may also be used to ensure the longitudinal composite action between the beam and the deck (Figure 9). As the fibres in the FRP tube are close to the hoop direction, the passing of steel bars through the tube is expected to affect little its overall performance.

CONCLUDING REMARKS

This paper has discussed the rationale and advantages of hybrid FRP-concrete-steel double-skin tubular members (i.e. hybrid DSTMs), provided a brief summary of existing and ongoing research on hybrid DSTMs, and discussed their potential applications in mining infrastructure. Hybrid DSTMs have a great potential for use in a roof support system for maingates and/or tailgates in longwall mining. The presence of an inner void in hybrid DSTMs is also an important advantage which can be exploited in mining applications. While existing and current research is mainly concerned with structural behaviour of hybrid

DSTMs, exciting opportunities exist for the exploration of real practical applications of such novel structural members in mining infrastructure.

ACKNOWLEDGEMENTS

The authors are grateful to their colleagues Drs. Ting Ren and Jan Nemcik for their valuable discussions in the preparation of this paper.

REFERENCES

- Fam, A Z and Rizkalla, S H, 2001. Behaviour of axially loaded concrete-filled circular fibre-reinforced polymer tubes, *ACI Structural Journal*, 98(3):280-289.
- GB 50010, 2002. *Code for design of concrete structures* (China Architecture and Building Press, China).
- GB 50608, 2011. *Technical Code for Infrastructure Application of FRP Composites* (China Planning Press, China).
- Mander, J B, Priestley, M J N and Park, R, 1988. Theoretical stress-strain model for confined concrete, *Journal of Structural Engineering*, ASCE, 114(8):1804-1826.
- Mirmiran, A and Shahawy, M, 1997. Behaviour of concrete columns confined by fibre composites, *Journal of Structural Engineering*, ASCE, 123(5):583-590.
- Pinto, A V, Molina, J and Tsionis, G, 2003. Cyclic tests on large scale models of existing bridge piers with rectangular hollow cross-section, *Earthquake Engineering and Structural Mechanics*, 32:1995-2012.
- Priestley, M J N, Seible, F, and Calvi, G M, 1996. *Seismic Design and Retrofit of Bridges* (John Wiley and Sons, Inc).
- Teng, J G, Yu, T, Wong, Y L and Dong, S L, 2007. Hybrid FRP-concrete-steel tubular columns: concept and behaviour, *Construction and Building Materials*, 21(4):846-854.
- Teng J G, Yu, T and Fernando, D, 2009. FRP composites in steel structures, in *Proceedings, the Third International Forum on Advances in Structural Engineering 2009*.
- Wong, Y L, Yu, T, Teng, J G and Dong, S L, 2008. Behaviour of FRP-confined concrete in annular section columns, *Composites: Part B-Engineering*, 39:451-466.
- Webb, J and Peyton, J J, 1990. Composite concrete filled steel tube columns, *Proceedings of the Structural Engineering Conference 1990*, pp 181-185.
- Yu, T, Wong, Y L, Teng, J G, Dong, S L and Lam, S S, 2006. Flexural behaviour of hybrid FRP-concrete-steel double skin tubular members, *Journal of Composites for Construction*, ASCE, 10 (5):443-452.
- Yu, T, Teng, J G, Wong, Y L and Dong, S L, 2010a. Finite element modelling of confined concrete-I: Drucker-Prager type plasticity model, *Engineering Structures*, 32(3):665-679.
- Yu, T, Teng, J G, Wong, Y L and Dong, S L, 2010b. Finite element modelling of confined concrete-II: plastic-damage model, *Engineering Structures*, 32(3):680-691.
- Yu, T, Teng, J G and Wong, Y L, 2010c. Stress-strain behaviour of concrete in hybrid double-skin tubular columns, *Journal of Structural Engineering*, ASCE, 136(4):379-389.
- Yu, T, Wong, Y L and Teng, J G, 2010d. Behaviour of hybrid FRP-concrete-steel double-skin tubular columns subjected to eccentric compression, *Advances in Structural Engineering*, 13(5):961-974.
- Yu, T and Teng, J G, 2011. Design of concrete-filled FRP tubular columns: Provisions in the Chinese technical code for infrastructure application of FRP composites, *Journal of Composites for Construction*, ASCE, 15(3):451-461.
- Zhao, X L and Han, L H, 2006. Double skin composite construction, *Progress in Structural Engineering and Materials*, 8:93-102.