



UNIVERSITY
OF WOLLONGONG
AUSTRALIA

University of Wollongong
Research Online

Coal Operators' Conference

Faculty of Engineering and Information Sciences

2011

Intrinsically Safe Communication and Tracking Technologies for Underground Coal Mines

L. Munday

CSIRO Earth Science and Resource Engineering

S. Addinell

CSIRO Earth Science and Resource Engineering

J. Thompson

CSIRO Earth Science and Resource Engineering

E. Widzyk-Capehart

CSIRO Earth Science and Resource Engineering

Publication Details

L. Munday, S. Addinell, J. Thompson and E. Widzyk-Capehart, Intrinsically Safe Communication and Tracking Technologies for Underground Coal Mines, 11th Underground Coal Operators' Conference, University of Wollongong & the Australasian Institute of Mining and Metallurgy, 2011, 197-204.

Research Online is the open access institutional repository for the University of Wollongong. For further information contact the UOW Library:
research-pubs@uow.edu.au

INTRINSICALLY SAFE COMMUNICATION AND TRACKING TECHNOLOGIES FOR UNDERGROUND COAL MINES

L Munday, S Addinell, J Thompson and E Widzyk-Capehart

ABSTRACT: The CSIRO, with funding assistance from Japan Coal Energy Center (JCOAL) and The Australian Coal Association Research Program (ACARP), has developed, tested and secured IEC Ex.ia certification via Simtars for an Ethernet Switch and via TestSafe for a Serial To Ethernet Converter (STEC) and a Paging and Location System (PLS). The STEC provides translation between serial data and Ethernet packets. Any device with a wired (i.e. copper) serial interface can be connected to the STEC; the device then becomes part of an optical fibre-based Ethernet network and is controllable and addressable using standard Ethernet communication protocols. The PLS is comprised of two devices: tags and nodes. The tags, small portable units that communicate wirelessly, can be attached to personnel and/or equipment within a mine. The tags have a paging function, enabling two-way messaging between personnel and the remote server (control room operator). The tags communicate with the remote server via the nodes; fixed units that communicate with each other and the control room via optical fibre. Tag locations are continuously tracked within the mine, providing the control room with the locations of all tagged personnel, vehicles and equipment. Prototypes of the technologies developed by CSIRO were tested and demonstrated at three mines.

INTRODUCTION

Underground mining is hazardous and no more so than in coal mines, with the risk of fire, methane gas and coal dust ignition. The best means of minimising these hazards are improved risk management, hazard control, personnel communication and personnel/equipment tracking. But none of these measures can be effectively implemented until there is a reliable communication network in place.

Such a communication network must be able operate at all times, even during loss of mine power, which is critical when the network is part of a safety system. In underground coal mines, equipment operating within an Explosive Risk Zone (ERZ), and that can operate independently of mine power must be approved as Intrinsically Safe (IS). This means that the equipment itself will not provide an ignition source, even if it develops a fault. The CSIRO's Mining Technology Research Group, has developed a set of intrinsically safe devices that enable Ethernet communication and personnel and equipment tracking in underground coal mines. These devices are:

- Ethernet Switch;
- Serial to Ethernet Converter;
- Paging and Location System;
- Server and software algorithms.

Figure 1 shows a typical configuration of these components. The Ethernet Switch provides the core of the communication system. It routes all packets of information over multi-mode or single-mode fibre, using Ethernet-over-fibre protocols. The STEC is a translation device; it converts data between any serial format and Ethernet packets. The PLS nodes and tags provide messaging and tracking functionality and have unique IDs, which allows them to be addressed individually by the server. The PLS Charger is used to recharge the Tags' batteries; it is not an intrinsically safe device and must remain in a Non-Explosive Risk Zone (NERZ),

The Server (in a NERZ or on the surface) runs the monitoring and control software, such as CSIRO's fully-featured risk management and monitoring application known as Nexsys™. PLS functionality is integrated with Nexsys™, allowing node and tag positions to be displayed on a mine map. Tag positions are constantly updated and each tag may be associated with a person or with a piece of equipment. For more details on Nexsys™ refer to Haustein *et al.*, 2008a and b.

A variety of media are used to provide the communication links: single-mode optical fibre for the long distance and high speed links, multi-mode optical fibre for the shorter range and lower speed links, copper wiring for the short range and low speed links, and radio frequencies for the wireless links.

Data can be sent to and from any device in the network using this software.

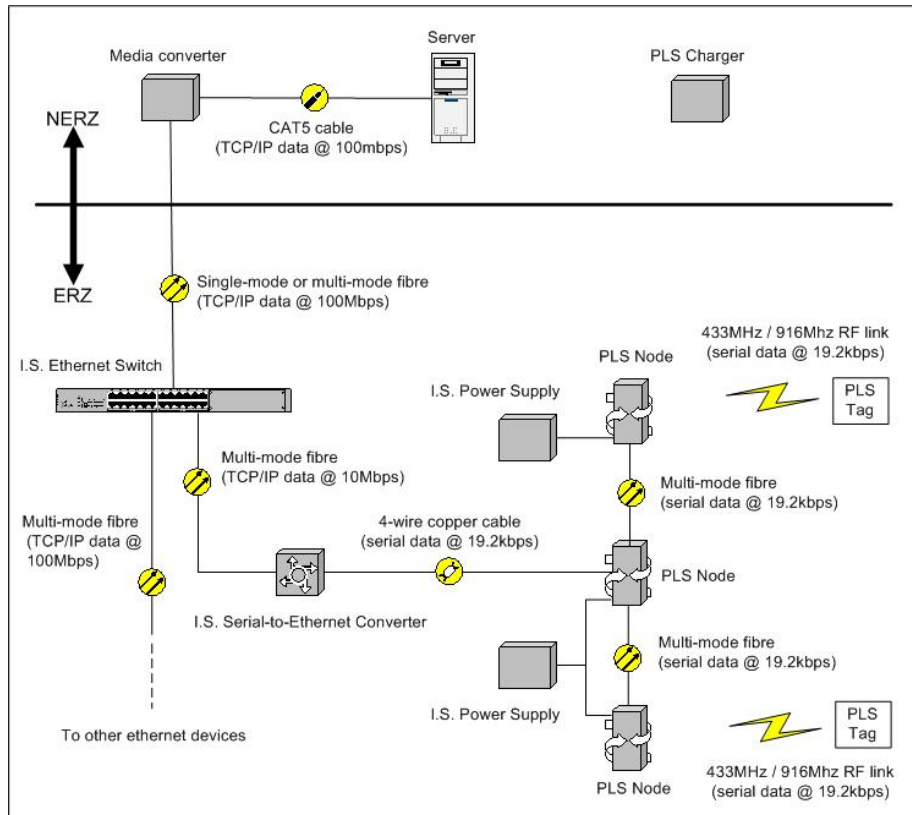

Figure 1 - Communication system overview

ETHERNET SWITCH

Figure 2 shows the assembled Ethernet Switch, that has been approved as intrinsically safe (IEC Ex.ia Group I) making it possible to use in underground coal environments. It is housed in an IP20 stainless steel enclosure, with dimensions of 270x220x82 mm (excluding protrusions).



Figure 2 - Ethernet switch

The Switch is layer-2 device used to route Ethernet packets. Use of the TCP/IP and UDP protocols over optical fibre provides many advantages: long transmission distances at high data rates, redundant data paths (i.e. spanning tree protocol) and an effectively unlimited number of devices that can be connected to the network. The Switch has five full-duplex optical fibre ports; ports 1, 2 and 3 adhere to the 100BaseFX specification. These ports operate at 100 megabits per second (Mbps) and may be

connected to multi-mode fibre (50/125 μm or 62.5/125 μm) that uses the 800 nm range or to single-mode fibre (9/125 μm) that uses the 1300 nm range. Ports 4 and 5 adhere to the 10BaseFL specification. These ports operate at 10 Mbps and may be connected only to multi-mode optical fibre (50/125 μm or 62.5/125 μm) that uses the 800nm range. Any combination of fibre connector types can be fitted to the unit at the time of manufacture. Two optical fibre cores are required per port; one for transmission and one for reception.

The Switch should be used in conjunction with an uninterruptible IS power supply (11-13V DC). This allows the Switch to operate independently of mains power, which is critical if the Switch is part of a safety system that works reliably, even in emergency situations. The production version of the Switch should be available in 2011 through CSIRO's commercial partner, AmpControl.

SERIAL TO ETHERNET CONVERTER

Figure 3 shows the Serial To Ethernet Converter (STEC), which has been approved as intrinsically safe (IEC Ex.ia Group I) making it possible for use in underground coal environments. It is housed in a DIN-mountable IP20 enclosure, which has dimensions of 150x110x75 mm (excluding protrusions).



Figure 3 - Serial to ethernet converter

The STEC has one wired serial port and one optical Ethernet port; it translates between serial-over-copper packets and Ethernet-over-fibre packets.

The optical fibre port is full duplex and operates at 10 Mbps (10BaseFL). The port is fitted with ST connectors for multi-mode fibre (62.5/125 m) and uses an 850 m wavelength. Two optical fibre cores are required; one for transmission and one for reception. The STEC has its own MAC address and IP, which means the serial device connected to it becomes addressable using standard TCP/IP or UDP communication tools. The copper serial port may be configured as RS422 or RS485. The serial data rate can range from 300 to 115200 bits per second and any asynchronous serial protocol can be used. In particular, the STEC has been tested extensively with the Modbus-RTU protocol and the proprietary PLS serial protocol. The STEC's user interface consists of an LCD and keypad, which allows the operator to configure and test the STEC in-situ. Many parameters can be set, including the MAC and IP address, the serial speed and the serial format.

The STEC should be used in conjunction with an uninterruptible IS power supply (9 to 13 V DC). This allows the STEC to operate independently of mains power, which is critical if the STEC is part of a safety system that must work reliably, even in emergency situations. The production version of the STEC should be available in 2011 through CSIRO's commercial partner, AmpControl.

PAGING AND LOCATION SYSTEM

The PLS consists of two primary hardware devices: tags and nodes. Both devices are approved as intrinsically safe (IEC Ex.ia Group I), making it possible to use them in underground coal mine environments. Tags are mobile units that communicate with the nodes wirelessly. The nodes communicate with each other (and the server) via serial-over-fibre links. A third component of the PLS is the Charger. It is used to recharge the Tags' internal batteries and can only be operated in a non-explosive risk zone.

Tags and nodes communicate wirelessly with each other and the server on a continuous basis; the use of unique device IDs allows tags and nodes to be addressed individually or in groups. Tags will generally be in wireless range of only 1 or 2 nodes at any time. This allows the server software to determine coarse tag locations.

Wireless communication is realised by a half-duplex radio frequency (RF) link, with the carrier set to either 433 MHz or 916 MHz (selectable at the time of manufacture). Most countries recognise one or both of these frequencies as falling within an ISM (Industrial, Scientific and Medical) band. These bands are license-free and may be used with little restriction. In Australia, the only restriction of these ISM bands is that (for a digitally-modulated, fixed-carrier transmitter) the maximum effective isotropic radiated power (EIRP) is 25 mW. The tag and node radios have maximum EIRP of 10 mW.

The 433 MHz and 916 MHz radio frequencies were also chosen as they exhibit good propagation characteristics in coal mine tunnels (Emslie, *et al.*, 1975). Additionally, these lower UHF frequencies propagate a given distance using less power than higher UHF frequencies (such as 2.4 GHz). Low power usage is particularly important for the tag, since it is battery powered.

PLS tag

Figure 4 shows a photograph of a PLS Tag. It is housed in a small IP55 plastic enclosure, which has dimensions of 100x52x25 mm. The enclosure is translucent, allowing internal LEDs to illuminate the case.

The tag's user interface consists of several parts, which are detailed below in Table 1.



Figure 4 - PLS tag

Table 1 - Tag user interface

Part	Description
LCD display	Messages and status information is displayed on the LCD.
Soft buttons	Three membrane keys can be used for any purpose; e.g. for specific responses to incoming messages. In the current version of the firmware, the three buttons always correspond to a "Yes", "No" or "OK" response.
Status LED	This dual-colour LED displays battery charging information and communications status information.
Vibration and Perimeter LEDs	A small vibration motor and a set of blue perimeter LEDs indicate communications and battery charging status.
Accelerometer	A 2-axis accelerometer senses vibration and tilt, which can be used to detect injured or incapacitated personnel.
Reed switch	This internal switch can be activated with a magnet in order to turn off the Tag.

On receipt of a message, the tag vibrates, the case illuminates and the message text is displayed on the LCD. The user can then respond to the message via the soft buttons. Additionally, a "Mayday" message can be sent by holding down any two buttons for five seconds.

PLS node

Figure 5 shows a prototype PLS Node. It is housed in an IP55 powder-coated steel enclosure, with dimensions of 300 x 200 x 100 mm.

A node has three serial ports and one wireless port. Data transmits the ports at 19 200 bps using the 8N1 format. Ports 2 and 3 are optical fibre ports (multimode 62.5/1125 m), while Port 1 can be configured as either a multi-mode fibre port or as copper port (RS422/RS485). All port cabling passes through glands and is terminated inside the enclosure.

A node has eight LEDs which are used to indicate activity on the communications ports; there is a transmit and receive LED for each port. When power is applied, they will flash LEDs briefly to indicate successful node initialisation.

Packets are routed between nodes using a simple scheme: any valid message received on a node's serial port that is not intended for that node, is retransmitted on all ports except for the port it was received on. This ensures that packets propagate through the network and will reach the desired destination/s.

A node should be used in conjunction with an uninterruptible IS power supply (11-13 V DC). This allows a node to operate independently of mains power, which is critical if the node is part of a safety system that must work reliably, even in emergency situations.

PLS charger

Figure 6 shows a prototype PLS Charger; a production unit would feature a more robust style of charging dock and would have facility for charging many tags simultaneously. The charger is housed in a plastic enclosure with dimensions of 240 x 160 x 90 mm.

An inductive charging method is used, which allows tags to be simply placed into a slot for charging. Additionally, there are no exposed charging contacts, thus increasing safety and reliability. Charging a tag may take up to 6 hrs if the tag's battery is near-flat.



Figure 5 - PLS node

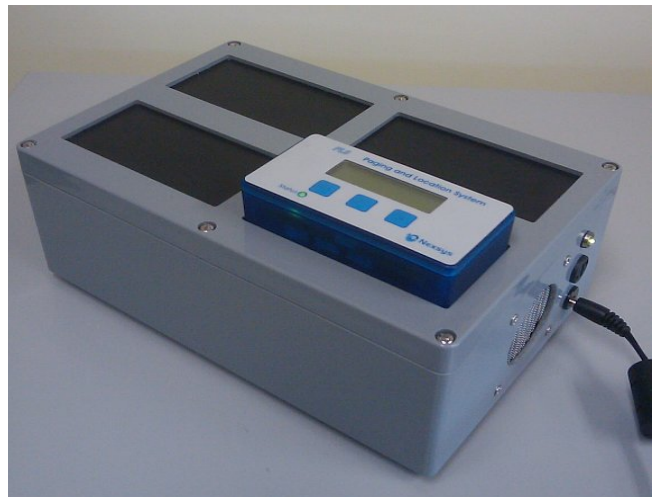

Figure 6 - PLS charger

FIELD TRIAL

Prototypes of the Ethernet Switch and STEC have been tested and demonstrated at several underground coal mines: Xstrata Beltana, Anglo Coal Grasstree and JCOAL Kushiro. The entire communication suite of devices and software was successfully installed and demonstrated at Kushiro mine; hence discussion of field trials will focus on the testing at this mine.

In November of 2006, the development team undertook a field trial of the Switch, STEC and PLS at the Kushiro coal mine in Japan. The system consisted of 1 Ethernet Switch, 2 STECS, 6 PLS tags, 3 PLS nodes and 1 PLS charger. The hardware was setup in a similar configuration as that shown in Figure 1.

Figure 7 shows the underground locations for the nodes. Node 1 (not shown) was placed at the muster area on the surface. Node 2 was placed 1577 m down the main drift. Node 3 was first placed 1790m down the main drift (labelled as position "Node3A"). Node 3 was later moved to the position labelled "Node3B".

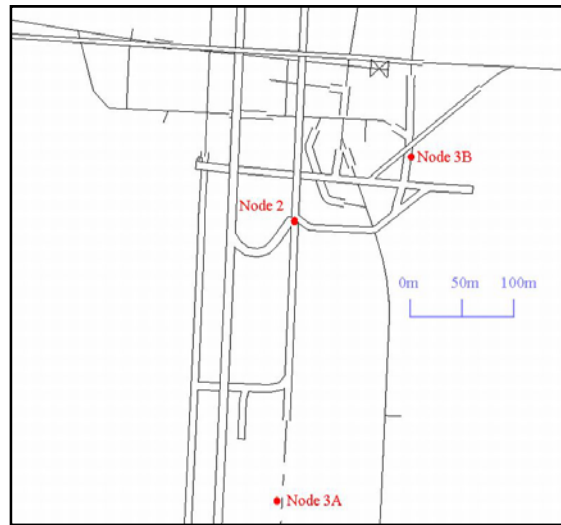

Figure 7 - Underground node locations

The aim of the trial was to test the performance of the Switch, STEC, PLS and server software. Since the PLS relied on all the other components operating correctly, its performance became the focus of the trial. Particular attention was paid to the RF performance of the PLS, since little information was known on its RF propagation characteristics. All tags and nodes were configured to operate at 433 MHz. The average effective isotropic radiated power for all the tags and nodes was between 7 mW and 9 mW.

Stage 1 testing

The primary aim of Stage 1 was to verify system operation and to test RF range in an above-ground office environment.

Note that the PLS tags can be configured to continuously display an "In Range of Node" or "Out of Range" message on their LCD, which was updated every few seconds. However, each tag's EIRP and RF sensitivity is slightly different. This is inherent in the circuit design and primarily due to the RF chip used. Hence, it was important to determine an average RF range for the tags. To achieve this, the tags were moved to various locations until one tag of the six showed "Out of range". The tags were then moved further away from the node until all tags showed "Out of range". Hence, the average RF range was taken to be approximately half-way between these two locations. Average RF range will be hereafter simply referred to as "RF range" to simplify explanation.

The tags were first activated in the control room. All 6 tags showed "Out of Range", which was not surprising considering that node 1 was two floors below and through several layers of steel and concrete (at least 50 m away in a straight line). The tags were then walked around the building, traversing several levels and passing close to node 1 on several occasions.

The result of this test showed that RF range varied from 30 m to 100 m and was highly dependent on the intervening materials between the tags and the node. With the tags on the same level as node 1, it was possible to walk up to 100 m away and still be in range. When traversing two levels above node 1, the RF range dropped to approximately 30 m. The building was constructed of steel-reinforced concrete so this result was not surprising, given that the radio frequency of interest (433 MHz) is readily absorbed by electrically conductive items.

Additionally, several messages were sent to the tags during the test. When the tags were in range of a node 1, or when they re-entered range, all messages were successfully received.

Stage 2 testing

Figures 8 and 9 show the underground environment in which the tags and nodes were operating. As can be seen, there is a significant amount of steel reinforcement and heavy copper cabling. The tracks shown in the photos are used by the drift train, which transfers workers between the muster area and the working area of the mine.



Figure 8 - Main drift, near Node 1



Figure 9 - Side tunnel, near Node 3B

Initially, the tags were walked up and down the drift, to traverse a few hundred metres either side of Node 2 and Node 3A. The tags were held in the hands of various CSIRO and Kushiro personnel, who were never more than 10m apart. The same method for determining RF range was used as detailed in stage 1. After several traversals of the drift, the average RF range for this test was found to be 120 m.

For the second test, the personnel holding tags boarded the drift train and the train traversed a few hundred metres either side of node 2 and node 3A. Some of the train doors were left open, while others were closed. Again the tags were hand-held and never more than 10 m apart. The RF range for this test was found to be 80 m. The lower RF ranges as compared to the first test can be explained by the shielding effect of the train's metal chassis.

The final test of stage 2 was designed to measure the overall communication latency when communicating with PLS tags. To achieve this, one of the CSIRO staff used the underground phone system to stay in contact with the server operator (situated in the control room). The operator then initiated a tag message and communicated this fact over the phone. Using a stopwatch, the underground personnel calculated the time for a message to be delivered. The tag user then responded to the message by pressing a button. Similarly, the time for the response to appear back at the server could be timed.

This procedure was repeated several times. The highest latency observed was 15 s, with tag messages and responses typically delivered within 5 s.

Stage 3 testing

The primary aims of stage 3 were to measure the RF range in an underground environment that contained lots of steel, and to test RF range in a non-line-of-sight situation.

As with Stage 2, a walk-test was performed a few hundred metres either side of the node (in this case node 3B). For this test all tags were placed on a plastic tray, and carried by one person, with the tray about 1m above ground level and held horizontally.

In the straight section of tunnel, the RF range was 110 m. In the other direction from the node (i.e. around the tunnel bend), the RF range was 90 m. Additionally, at one point a string of coal carts passed by on the track, which temporarily increased the RF range to 110 m. This 20 m effective increase in range was due to the coal carts acting as a waveguide.

As a final test for stage 3, the tags were taken into a side passage and through several brattice stoppings. The RF range was found to be 30 m. This was not surprising given the smaller aperture of the side passage and the presence of the stoppings.

Summary

Table 2 summarises the RF ranges observed during the various stages of the field trial. Several conclusions can be made from the Kushiro field trial. Firstly, the RF range of the tags and nodes is highly dependent on the materials in the surrounding environment. In a line-of-sight situation with no obstructions, the RF range was typically 110 m. Moving a tag out of sight of a node (i.e. moving slightly around a bend in tunnel) reduced the RF to approximately 90m. Moving into a side tunnel, which had a smaller aperture and non-metallic stoppings, significantly reduced the RF range to 30m. Conversely, the RF range actually increased by about 20 m when there was conducting structures or vehicles nearby.

Table 2 - RF range results

Stage #	Test description	RF range (m)
1	Same level as node 1	100
1	Two levels up from node 1	30
2	On foot	120
2	On train	80
3	In straight tunnel	110
3	Around the bend	90
3	Side passage	30

CONCLUSIONS

This paper discussed three intrinsically safe communication devices, all approved as Ex.ia Group I and targeted for use in underground coal mines. The Switch provides core routing capability for an optical fibre network and enables Ethernet devices to be readily utilised underground. The STEC provides Ethernet-over-fibre to serial-over-copper translation, enabling a wide variety of serial devices to be connected into a mine's existing Ethernet fibre network. The PLS enhances productivity and safety with its messaging and tracking functionality. All of these communication devices, when used in conjunction with uninterruptable IS power supplies, will operate independently of mine power. This is critical if these devices form part of a safety system that must work reliably, even in emergency situations.

REFERENCES

- Haustein K, Rowan G, Beitz A, and Widzyk-Capehart E, 2008a. The Nexsys™ Realtime Risk Management System for Advanced Decision Support, in *Proceedings of the 5th International Symposium on Risk Management and Cyber-Informatics: RMCI 2008 (in the context of The 12th Multi-Conference on Systematic, Cybernetics and Informatics: WMSCI 2008)*, 29 July - 2 July, Orlando, Florida, USA.
- Haustein K, Widzyk-Capehart E, Beitz A and Hainsworth D, 2008b. Nexsys™: A Realtime Risk Management System for Mine Safety. *Queensland Mining Industry Health and Safety Conference "Breaking New Ground"*, 17-20 August, Townsville, QLD.
- Emslie G, Lagace R and Strong P, 1975. Theory of the Propagation of UHF Radio Waves in Coal Mine Tunnels, *IEEE Transactions on Antennas and Propagation*, 23, pp 192-205.

THE NEXSYS™ REAL-TIME RISK MANAGEMENT AND DECISION SUPPORT SYSTEM: REDEFINING THE FUTURE OF MINE SAFETY

Kerstin Haustein¹, Eleonora Widzyk-Capehart¹, Peter Wang², Dean Kirkwood³ and Ricky Prout³

ABSTRACT: Underground coal mine control rooms are inundated with data but there remains a lack of information enabling timely decision making. Control room operators' cognitive abilities are stretched beyond their limits; processing of the vast array of data sourced from multiple, non-compatible proprietary systems coupled with old communications systems makes the job of a control room operator extremely challenging, if not impossible, particularly in emergency situations when speed and accuracy are of great importance.

The CSIRO has developed a real-time risk management software called Nexsys™. Nexsys™ is a decision-support system designed for the collection and integration of disparate mine data, real-time analysis of safety critical data and real-time risk profiling using rules-based trigger action response plans. The system allows access to a wide range of risk management data in an easily interpretable format and in real-time, such as, availability of messaging and tracking data to precisely determine the location of all personnel, vehicles and equipment at all times. Through compatibility with an optical fibre underground communication network, which uses intrinsically-safe equipment and keeps the data network alive during power shutdown, an access to sensor data during emergency conditions (power shutdown) is available. The software system has a risk preventive and predictive capability, ability to track people and equipment underground, and the provision of 2-way communication via the operator's interface. The system is designed to make risk management-related data immediately available to the operator and to reduce the amount of irrelevant and unnecessary data, such as false alarms.

Nexsys™ has the potential to radically reshape safety in the underground coal mining industry and has the future potential to be adapted to surface coal mining, metalliferous mining and non-mining applications, where safety and decision support are critical operational characteristics.

INTRODUCTION

The dangers associated with underground mining operations raise a compelling need for risk management and accident prevention. It is certainly true that the coal mine control room of 2010 is infinitely more sophisticated than its predecessors; however, during each shift, millions of bits of data can be transmitted into a control room from all areas of mine operation and covering everything from gas levels to temperature, movements of mining equipment, and personnel location. While significant advances in solving problems associated with transmitting data within mines has been made over the last several years, the challenge remains in the ability to analyse these massive amounts of data and convert it into useful information for both production and safety management. In particular, emergency situations place extreme demands on effective information management, both in the response to the development of a potentially safety-critical situation and, if unavoidable, during an incident itself.

Many incident and accident evaluations have shown that although predictive data was available, it was often too ambiguous, incomplete or scattered across a number of disparate proprietary systems to effectively deliver vital information to mine site personnel in a form that would allow appropriate pre-emptive responses (Einicke and Rowan, 2005). If this data had been properly managed and interpreted, it is likely that many of the incidents or accidents could have been prevented or their consequences reduced. Cliff and Grieves (2010) stated that "the control room in particular is a key area where accurate information is required during an incident especially in the early stages until a senior mine official can take charge. The control room remains the first point of contact during an incident for most personnel. Speedy evacuation and in-seam response is predicated upon knowing what is happening and

¹ CSIRO Earth Science and Resource Engineering, Brisbane QLD 4069, kerstin.haustein@csiro.au

² CSIRO ICT Centre, Sydney NWS 2122

³ Mining Logic Solutions, Mackay QLD 4740