

Faculty of Informatics

Faculty of Informatics - Papers

University of Wollongong

Year 2006

STC-MIMO Block Spread OFDM in Frequency Selective Rayleigh Fading Channels

L. C. Tran* X. Huang†
E. Dutkiewicz‡ J. F. Chicharo**

*University of Wollongong

†University of Wollongong, huang@uow.edu.au

‡University of Wollongong, eryk@uow.edu.au

**University of Wollongong, chicharo@uow.edu.au

This article was originally published as: Tran, LC, Huang, X, Dutkiewicz, E & Chicharo, J, STC-MIMO Block Spread OFDM in Frequency Selective Rayleigh Fading Channels, Proceedings of the 11th IEEE Symposium on Computers and Communications (ISCC '06), 26-29 June 2006, 277-282. Copyright IEEE 2006.

This paper is posted at Research Online.

<http://ro.uow.edu.au/infopapers/457>

STC-MIMO Block Spread OFDM in Frequency Selective Rayleigh Fading Channels

Le Chung Tran, Xiaojing Huang, Eryk Dutkiewicz and Joe Chicharo
Wireless Technologies Laboratory (WTL)
Telecommunications & Information Technology Research Institute
Faculty of Informatics, University of Wollongong
Wollongong, NSW 2522, Australia
{lct71,huang,eryk,chicharo}@uow.edu.au

Abstract

In this paper, we expand the idea of spreading the transmitted symbols in OFDM systems by unitary spreading matrices based on the rotated Hadamard or rotated Discrete Fourier Transform (DFT) matrices proposed in the literature to apply to Space-Time Coded Multiple-Input Multiple-Output OFDM (STC-MIMO-OFDM) systems. We refer the resulting systems to as STC-MIMO Block Spread OFDM (STC-MIMO-BOFDM) systems. In the proposed systems, a multi-dimensional diversity, including time, frequency, space and modulation diversities, can be used, resulting in better bit error performance in frequency selective Rayleigh fading channels compared to the conventional OFDM systems with or without STCs. Simulations carried out with the Alamouti code confirm the advantage of the proposed STC-MIMO-BOFDM systems.

1. Introduction

Orthogonal Frequency Division Multiplexing (OFDM) has been intensively considered in the literature for transmitting signals over frequency selective fading channels. The main advantage of the OFDM technique compared to a single carrier modulation is that it facilitates the use of high data rates with a relatively low complexity receiver, which requires only a Fast Fourier Transform (FFT) processor followed by single tap equalizers across all subcarriers. OFDM systems possess a diversity gain over single carrier systems since the orthogonality of the subcarriers prohibits multipaths from being combined across the channel at the symbol level.

The use of spreading matrices to mix the transmitted symbols linearly across the subchannels has been considered for single antenna wireless communications systems in the literature, such as in [16], [2]. The main advantage of using spreading matrices is that it allows us to achieve a diversity over the frequency selective fading channels. The use of

unitary spreading matrices based on the *rotated* Hadamard or *rotated* Discrete Fourier Transform (DFT) matrices to improve the performance of single antenna OFDM systems was firstly introduced by Bury et.al. [2] and further studied by McCloud [7].

It is well known that the use of multiple transmit and/or receive antennas can significantly improve the capacity of wireless communications systems. Such systems are called Multiple Input Multiple Output (MIMO) systems. Space-Time Codes (STCs) are the codes designed for the use in MIMO systems. Space-Time Block Codes (STBCs) [1], [11], [13], Space-Time Trellis Codes (STTCs) [12], Bell Lab Layered Space-Time (BLAST) [3] are among various types of STCs. The combination of MIMO systems using STCs with the OFDM technique has received a fair amount of attention in the literature, such as in [10], [8], [15], [9], [5]. However, the combination of MIMO systems using STCs with the *block spread* OFDM technique has not been considered yet. This combination is expected to improve further the performance of the whole system at the cost of slightly more complicated transmitter and receiver structures.

In this paper, we expand the idea of Block Spread OFDM (BOFDM) mentioned in [2], [7] to apply to the MIMO-OFDM systems using STCs. We call the resultant technique STC-MIMO-BOFDM to distinguish it from the normal MIMO-OFDM without block spreading. It is noted that the term “spreading” is inherited from [2] to express the modulation alphabet expansion, rather than the bandwidth expansion as the normal meaning of this term.

The novel contributions of this paper include 1) the *application* of the block spreading technique to the conventional STC-MIMO-OFDM systems to improve further the error performance of the STC-MIMO-OFDM systems; 2) the *derivation* of the more detailed Simple Maximum Likelihood (SML) decoding method [6] for the proposed STC-MIMO-BOFDM systems using the Alamouti code [1]; and 3) the error performance *comparison* between the proposed STC-MIMO-BOFDM systems and the conventional OFDM

systems (without STCs or block spreading), BOFDM systems (without STCs) [7] and STC-MIMO-OFDM systems (without block spreading) [6], [14].

The paper is organized as follows. In Section 2, we derive the baseband model of an STC-MIMO-BOFDM system. Section 3 derives a detailed decoding algorithm, namely Simple Maximum Likelihood (SML), which was originally derived in [6], for a particular example of the Alamouti code. Simulation results are given in Section 4, and the paper is concluded by Section 5.

2 STC-MIMO Block Spread OFDM System Model

The model of the baseband STC-MIMO-BOFDM systems is given in Fig. 1. We consider here an STC-MIMO-BOFDM system with N OFDM subcarriers, M_t transmit (Tx) antennas and M_r receive (Rx) antennas.

At each time t , a block of information bits is encoded to generate a space-time code word consisting of $T \times M_t$ modulated symbols as follows:

$$\mathbf{S}^t = \begin{bmatrix} s_{1,1}^t & \cdots & s_{1,M_t}^t \\ \cdots & \cdots & \cdots \\ s_{T,1}^t & \cdots & s_{T,M_t}^t \end{bmatrix}, \quad (1)$$

where the symbols $s_{k,i}^t$ are drawn from a signal constellation \mathbb{S} . For simplicity, we select $T = N$, that is, each modulated symbol modulates an OFDM subcarrier.

In contrast with the conventional STC-MIMO-OFDM systems, in our proposed STC-MIMO-BOFDM systems, each column of the code word \mathbf{S}^t is divided into small blocks, each containing M symbols. Each block is then multiplied with a unitary spreading matrix \mathbf{U}_M . The data streams are then interleaved and OFDM modulated.

The idea of spreading the transmitted symbols with the unitary spreading matrices based on the rotated Hadamard or DFT matrices was firstly proposed in [2], and further examined for the BOFDM systems (single antenna systems without using STCs) in [7], and is expanded for the STC-MIMO-BOFDM system in this paper. The main idea of block spreading in the STC-MIMO-BOFDM systems is to split the full set of the subcarriers into smaller blocks and spread the transmitted symbols across these blocks via unitary spreading matrices in order to gain *multipath diversity* across each block at the receiver. In addition, the spreading transform using the rotated Hadamard or DFT matrices can be considered as a code in Euclidean space [2]. Block spreading using the rotated Hadamard or DFT matrices tends to expand the signal modulation alphabet and increase the Euclidean distance between sequences after being spread, compared to the normal Hadamard or DFT matrices [2]. In other words, besides having a *multipath diversity*, block spreading using the rotated Hadamard or DFT matrices also possesses a certain *modulation diversity*.

Consequently, a combined diversity, including time (STCs and interleaving), frequency (subcarriers), space

(STCs) and modulation diversities (block spreading), can be used in the STC-MIMO-BOFDM systems, resulting in better bit error performance in frequency selective Rayleigh fading channels compared to the conventional OFDM systems with or without STCs.

The $M \times M$ -size unitary spreading matrices \mathbf{U}_M used in this paper can be either the *rotated* Hadamard matrix or the *rotated* DFT matrix which has been mentioned in [2]

$$\mathbf{U}_M = \mathbf{Z} \text{diag}\{\alpha_m\} \quad 0 \leq m \leq M-1, \quad (2)$$

where diag denotes the diagonal matrix and $\alpha_m = e^{j\theta_m}$, for $0 \leq m \leq M-1$, are selected to achieve diversity advantage, where $\theta_m = \pi m/C$. Here C is chosen so that $2\pi/C$ is the smallest angle which rotates the signal constellation back to itself. For instance, we have $C = 2^b$ for the signal constellation 2^b -PSK (b is an integer), while for QAM constellations such as 16-QAM or 64-QAM, we have $C = 4$. \mathbf{Z} is either the Hadamard matrix of order M or a DFT matrix of order M which is defined by its elements as [2]

$$Z_{i,k} = \frac{1}{\sqrt{M}} \exp\left(-j2\pi \frac{(i-1)(k-1)}{M}\right). \quad (3)$$

We represent the code word after being interleaved and OFDM modulated as

$$\mathbf{X}^t = \begin{bmatrix} x_{1,1}^t & \cdots & x_{1,M_t}^t \\ \cdots & \cdots & \cdots \\ x_{N,1}^t & \cdots & x_{N,M_t}^t \end{bmatrix}, \quad (4)$$

where each symbol is formed by modulating a symbol in (1) with a certain subcarrier. The modulation is carried out by IFFT processors.

To avoid the inter symbol interference (ISI) due to the delay spread of the channel, a cyclic prefix (CP) is appended to each OFDM frame during a guard time interval (GI). CP is a copy of the last L samples of each OFDM frame and is appended to the beginning of that frame, making the overall length of an OFDM frame equal to $(N+L)$. If we assume that the channel comprises L_P paths, then L should satisfy $L \geq L_P$. After the CP is appended, \mathbf{X}^t has a size of $(N+L) \times M_t$, which is transmitted via M_t Tx antennas and each column is the data sequence of $(N+L)$ symbols transmitted simultaneously in an OFDM frame.

Although the time domain model is conceptually straightforward, it is much more insightful to consider the system in the frequency domain. We assume that the channel is frequency selective and time-invariant (slow fading) during the transmission of one OFDM symbol. The frequency-domain model of the STC-MIMO-BOFDM system after removing the CP at time t is

$$Y_{k,j}^t = \sum_{i=1}^{M_t} H_{j,i}^{t,k} x_{k,i}^t + W_{k,j}^t, \quad (5)$$

where $H_{j,i}^{t,k}$ is the channel frequency response for the path from the i -th Tx antenna ($i = 1, \dots, M_t$) to the j -th Rx

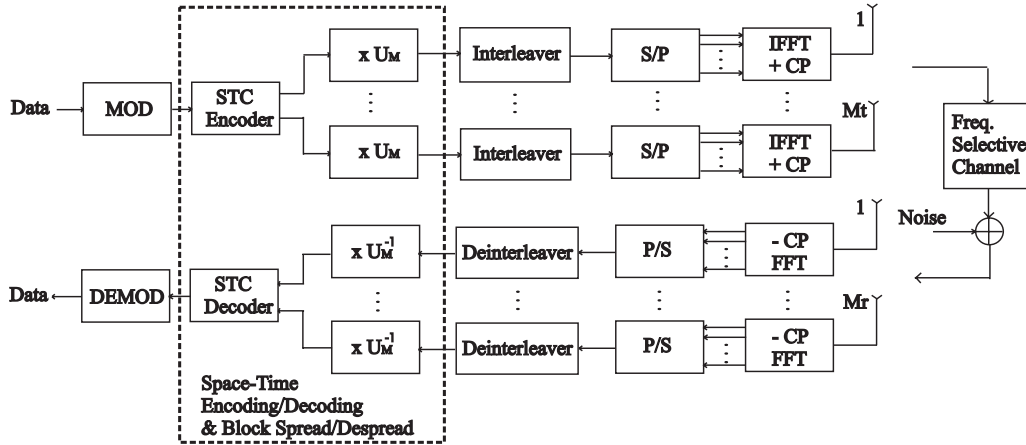

Figure 1. STC-MIMO-BOFDM system model

antenna ($j = 1, \dots, M_r$) on the k -th OFDM subcarrier ($k = 1, \dots, N$) and $W_{k,j}^t$ is a noise sample at the output of OFDM demodulators (FFT). $W_{k,j}^t$ is the N -point discrete Fourier transform of the corresponding discrete time noise sample, and can be modeled as a complex Gaussian random variable with zero mean and power $N_0/2$ per dimension. It is known that $H_{j,i}^{t,k}$ can be calculated as

$$H_{j,i}^{t,k} = \mathbf{h}_{j,i}^t \mathbf{w}_k, \quad (6)$$

with

$$\begin{aligned} \mathbf{h}_{j,i}^t &= [h_{j,i}^{t,1}, h_{j,i}^{t,2}, \dots, h_{j,i}^{t,L_P}], \\ \mathbf{w}_k &= [e^{-2\pi k/N}, e^{-2\pi 2k/N}, \dots, e^{-2\pi L_P k/N}]^T, \end{aligned} \quad (7)$$

where $h_{j,i}^{t,l}$ is the impulse response of the channel between the i -th Tx antenna and the j -th Rx antenna in the l -th multipath ($l = 1, \dots, L_P$) at time t , and $(\cdot)^T$ denotes the transposition operation. In this paper, the channel coefficients $H_{j,i}^{t,k}$ are assumed to be known at the receiver.

3 SML Decoding Algorithm

In this section, we illustrate an example of the two Tx antenna (i.e. $M_t = 2$) and one Rx antenna ($M_r = 1$) STC-MIMO-BOFDM system using the Alamouti code [1] given below

$$\begin{bmatrix} x_1 & x_2 \\ -x_2^* & x_1^* \end{bmatrix}, \quad (8)$$

where $*$ denotes the complex conjugate. In Eq. (8), the two columns are transmitted via the two Tx antennas while the two symbols in each column are modulated by the two consecutive k -th and $(k+1)$ -th subcarriers. At the receiver, the CP is removed. The received signals are then deinterleaved

and despread by multiplying the resultant signals with the inverse unitary spreading matrix \mathbf{U}_M^{-1} .

For simplicity, we still use similar notations as in Eq. (5) for the received signals after being deinterleaved and despread. Let us consider an STC-MIMO-BOFDM frame consisting of N symbols (N is normally chosen to be a power of 2 to facilitate the IFFT and FFT). As a certain OFDM frame is being considered and the system comprises one Rx antenna, for the ease of exposition, we omit the superscript t and subscript j in (5). The transmitted symbols in the OFDM frame via two Tx antennas are expressed as

$$\begin{bmatrix} x_1 & -x_2^* & \dots & x_{N-1} & -x_N^* \\ x_2 & x_1^* & \dots & x_N & x_{N-1}^* \end{bmatrix}^T, \quad (9)$$

where symbols in each column are simultaneously transmitted via one Tx antenna in one OFDM frame. If we denote

$$\mathbf{H} = \begin{bmatrix} H_1^1 & H_2^1 & 0 & 0 & 0 & 0 \\ H_2^{2*} & -H_1^{2*} & 0 & 0 & 0 & 0 \\ \dots & \dots & \dots & \dots & \dots & \dots \\ 0 & 0 & 0 & 0 & H_1^{N-1} & H_2^{N-1} \\ 0 & 0 & 0 & 0 & H_2^{N*} & -H_1^{N*} \end{bmatrix},$$

$$\mathbf{X} = [x_1, x_2, \dots, x_N]^T,$$

$$\mathbf{W} = [W_1, W_2^*, \dots, W_{N-1}, W_N^*]^T,$$

$$\mathbf{Y} = [Y_1, Y_2^*, \dots, Y_{N-1}, Y_N^*]^T, \quad (10)$$

then Eq. (5) can be equivalently expressed as follows:

$$\mathbf{Y} = \mathbf{H}\mathbf{X} + \mathbf{W}. \quad (11)$$

In (10), the superscript of H_i^k indicates the subcarrier index while the subscript indicates the Tx antenna index. By multiplying both sides of Eq. (11) with a matrix $\mathbf{C}_N = \mathbf{A}_N \mathbf{H}^H$, we have

$$\begin{aligned} \mathbf{Y}_N &= \mathbf{C}_N \mathbf{Y} = \mathbf{A}_N \mathbf{H}^H \mathbf{H} \mathbf{X} + \mathbf{A}_N \mathbf{H}^H \mathbf{W}, \\ \mathbf{Y}_N &= \mathbf{H}_N \mathbf{X} + \mathbf{W}_N, \end{aligned} \quad (12)$$

where $(\cdot)^H$ denotes the Hermitian transpose operation; $\mathbf{W}_N \triangleq \mathbf{A}_N \mathbf{H}^H \mathbf{W}$; the matrix \mathbf{A}_N is selected so that the diagonal elements of $E(\mathbf{W}_N \mathbf{W}_N^H)$ are N_0 and given by

$$\mathbf{A}_N = \text{diag}(\alpha_1^{-1/2}, \alpha_2^{-1/2}, \dots, \alpha_N^{-1/2}) \quad (13)$$

and

$$\mathbf{H}_N = \mathbf{A}_N \mathbf{H}^H \mathbf{H} = \begin{bmatrix} \alpha_1^{1/2} & \beta_{1,2} \alpha_1^{-1/2} & \dots & 0 \\ \beta_{1,2}^* \alpha_2^{-1/2} & \alpha_2^{1/2} & \dots & 0 \\ \dots & \dots & \dots & \dots \\ 0 & 0 & \alpha_{N-1}^{1/2} & \beta_{N-1,N} \alpha_{N-1}^{-1/2} \\ 0 & 0 & \beta_{N-1,N}^* \alpha_N^{-1/2} & \alpha_N^{1/2} \end{bmatrix} \quad (14)$$

where

$$\begin{aligned} \alpha_k &= |H_1^k|^2 + |H_2^{k+1}|^2, \\ \alpha_{k+1} &= |H_1^{k+1}|^2 + |H_2^k|^2, \\ \beta_{k,k+1} &= H_1^{k*} H_2^k - H_1^{k+1*} H_2^{k+1}, \end{aligned} \quad (15)$$

for $k = 1, 3, 5, \dots, N-1$.

In this paper, we use the SML decoding method [6] for our proposed STC-MIMO-BOFDM systems in the considered scenario. The main reasons for this are: 1) the computational complexity for decoding signals is linearly proportional to the size of OFDM frames and is much simpler than other decoding methods such as the sphere decoding method [4], and 2) the computational complexity for decoding signals is linearly proportional to the number of Tx (or Rx) antennas, rather than roughly cubic as in the sphere decoding method, in the case of $M_t = M_r$ [4]. Therefore, by using the SML decoding method, the computational effort is significantly reduced, facilitating the utilization of large numbers N and M as well as large size signal constellations \mathbb{S} .

In the SML decoding method, the transmitted signals are decoded without considering the correlation of the noise \mathbf{W}_N and the crosstalk, that is, the off-diagonal elements of the matrix \mathbf{H}_N in (14). Therefore, the symbols transmitted in an OFDM frame can be decoded separately, rather than jointly, as follows:

$$\hat{x}_k = \arg \min_{x \in \mathbb{S}} \{ |\mathcal{Y}_k - \alpha_k^{1/2} x|^2 \}, \quad (16)$$

for $k = 1, \dots, N$. In (16), \mathcal{Y}_k denotes the k -th element of \mathbf{Y}_N .

This decoding algorithm comes at the cost of inferior error performance compared to other complicated decoding methods, such as Joint Maximum Likelihood (JML), Zero Forcing (ZF), Decision Feedback (DF) [6]. Consequently, the simulation results derived in this paper just aim at giving the readers the lower bound of the performance of the considered system. In other words, the advantage of our proposed STC-MIMO-BOFDM system can be improved even further if we use more complicated decoding methods.

Table 1. Parameters for Simulations

Parameter	Value
Number of subcarriers N	64
Cyclic prefix L	16
Bandwidth (Sampling frequency) F_s	20 MHz
Number of multipaths L_P	3, 4 or 9
Maximum Doppler frequency F_D	50 Hz or 100 Hz
power delay profile (pdp)	Exponential decay
Size of spreading matrix M	16 or 32
Spreading matrix \mathbf{U}_M	Rotated Hadamard or Rotated DFT matrix
Signal constellation \mathbb{S}	BPSK, QPSK, 4QAM or 8PSK

4 Simulation Results

In this section, we consider an STC-MIMO-BOFDM system using the Alamouti code with 2 Tx antennas and 1 Rx antenna (more precisely, this is a Multiple-Input Single-Output (MISO) system, which is a special case of MIMO systems where $M_r = 1$). Several Monte-Carlo simulations are carried out with the transmission of 30,000 OFDM symbols, based directly on the analysis mentioned previously in Section 3. Parameters used for the simulations are given in Table 1. We compare the bit error performance of our proposed STC-MIMO-BOFDM system with that of three other systems, namely conventional OFDM system (without STCs or block spreading), BOFDM system (without STCs) [7] and STC-MIMO-OFDM system (without block spreading) [6], [14]. We assume that the Tx antennas are uncorrelated, that is, those antennas are separated far enough from each other so that the fading processes affecting those antennas can be considered to be independent. The block interleaver and deinterleaver are utilized in all simulations. The block interleaving is carried out as follows. Data are written in column-wise in a $(\frac{N}{2} \times 2)$ -sized matrix from top to bottom and from left to right. Data are then read out row-wise from left to right and from top to bottom. The signal-to-noise ratio SNR here means the average SNR per symbol. The channel is considered to be quasi-static so that the channel coefficients are constant during each OFDM frame. To model the frequency selective multipath Rayleigh fading channel, the time delay $\Delta\tau_l$ between two consecutive $(l+1)$ -th and l -th paths of the channel is assumed to be equal to the sampling period $T_s = 1/F_s$, i.e. $\Delta\tau_l = T_s$ for $l = 1, \dots, L_P - 1$. We also assume that the channel power delay profile (pdp) follows the exponential decay law $[1, e^{-1}, \dots, e^{-(L_P-1)}]$.

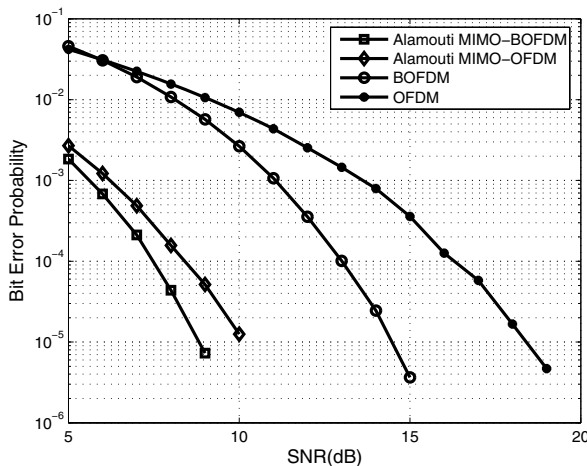

Figure 2. Performance of the Alamouti STC-MIMO-BOFDM system with $L_P = 3$, $M = 16$, $F_D = 100$ Hz, and a BPSK constellation.

Fig. 2 shows the case where the size of spreading matrices $M = 16$, the number of multipaths $L_P = 3$, the maximum Doppler frequency $F_D = 100$ Hz, and the BPSK constellation are simulated. We can see from the figure that the use of block spreading provides the improvement of the bit error performance in both single antenna and multiple antenna systems (or MIMO systems). The proposed STC-MIMO-BOFDM system provides the best performance among the considered systems. In particular, it provides an 1.2 dB SNR gain over the STC-MIMO-OFDM system at $BER = 10^{-5}$.

In Fig. 3, we consider the performance of the three systems STC-MIMO-BOFDM, STC-MIMO-OFDM and BOFDM in the scenario where $M = 16$, $L_P = 3$, $F_D = 100$ Hz, and the QPSK (or 4QAM) constellation are simulated. An 1 dB SNR gain can be achieved by the proposed STC-MIMO-BOFDM system at $BER = 10^{-5}$, compared to the conventional STC-MIMO-OFDM system, while a 5dB gain can be achieved by the STC-MIMO-BOFDM system, compared to the conventional BOFDM system.

The scenario where $M = 32$, $L_P = 4$, $F_D = 100$ Hz, and an 8PSK constellation are simulated is shown in Fig. 4. Similarly, the proposed STC-MIMO-BOFDM system provides the best bit error performance with a 3 dB SNR gain over the conventional STC-MIMO-OFDM system at $BER = 10^{-5}$ and with a 5.5 dB gain over the BOFDM system. All aforementioned simulations are carried out with the rotated Hadamard matrices which are calculated following (2).

Finally, in Fig. 5, we simulate the three systems with $M = 16$, $L_P = 9$, $F_D = 50$ Hz, a QPSK (or 4QAM) constellation and the rotated DFT matrix whose elements are calculated following (3). Again, the proposed STC-MIMO-

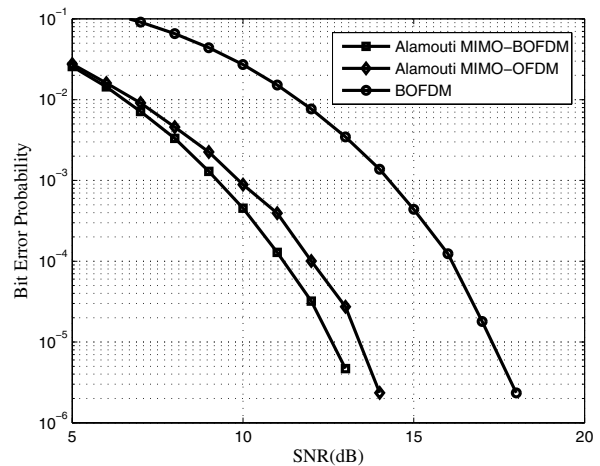

Figure 3. Performance of the Alamouti STC-MIMO-BOFDM system with $L_P = 3$, $M = 16$, $F_D = 100$ Hz, and a QPSK (or 4QAM) constellation.

BOFDM system provides the best bit error performance with a 2 dB SNR gain over the conventional STC-MIMO-OFDM system at $BER = 10^{-5}$.

It is noted that, besides depending on the modulation scheme, the behavior of the proposed STC-MIMO-OFDM technique also depends on other parameters, such as the size of spreading matrices M , the number of multipaths L_P and the maximum Doppler frequency F_D . Therefore, the gains achieved by the STC-MIMO-OFDM technique might be different, even for the same modulation constellations.

Interestingly, we can see from Fig. 5 that the performance curve of the BOFDM systems using block spreading comes close to that of the MIMO-OFDM systems (without block spreading) at high $SNRs$. Therefore, we can conclude that BOFDM systems may provide better bit error performance than MIMO-OFDM systems in some scenarios. This also means that the former may possess higher diversity orders than the latter at high $SNRs$.

5 Conclusions

In this paper, we have expanded the idea of using *block spreading* to improve the bit error performance of OFDM systems over frequency selective multipath Rayleigh fading channels to apply to STC-MIMO-OFDM systems, resulting in so-called STC-MIMO-BOFDM systems. Simulations show that the proposed STC-MIMO-BOFDM systems provide considerable improvements in the bit error performance compared to the conventional STC-MIMO-OFDM systems, and provide much better performance, compared to the BOFDM and conventional OFDM systems. This ad-



Figure 4. Performance of the Alamouti STC-MIMO-BOFDM system with $L_P = 4$, $M = 32$, $F_D = 100$ Hz, and an 8PSK constellation.

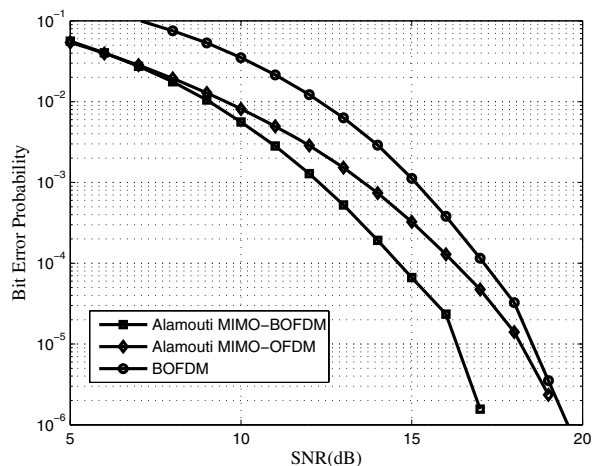

Figure 5. Performance of the Alamouti STC-MIMO-BOFDM system with $L_P = 9$, $M = 16$, $F_D = 50$ Hz, a QPSK (or 4QAM) constellation, and rotated DFT matrices.

vantage comes at the cost of a slightly more complicated system structure.

6 Acknowledgement

L. C. Tran would like to thank T. C. Le and T. H. Phan for helpful comments on the paper.

References

- [1] S. M. Alamouti. A simple transmit diversity technique for wireless communications. *IEEE J. Select. Areas Commun.*, 16(8):1451–1458, Oct. 1998.
- [2] A. Bury, J. Egle, and J. Lindner. Diversity comparison of spreading transforms for multicarrier spread spectrum transmission. *IEEE Trans. Commun.*, 51(5):774–781, May 2003.
- [3] G. J. Foschini. Layered space-time architecture for wireless communication in a fading environment when using multi-element antennas. *Bell Labs Technical Journal*, 1(2):41–59, Autumn 1996.
- [4] B. Hassibi and H. Vikalo. On the sphere-decoding algorithm I. Expected complexity. *IEEE Trans. Sign. Process.*, 53(8):2806–2818, Aug. 2005.
- [5] J. Kim, R. W. Heath, and E. J. Powers. Receiver designs for Alamouti coded OFDM systems in fast fading channels. *IEEE Trans. Wireless Commun.*, 4(2):550–559, Mar. 2005.
- [6] D.-B. Lin, P.-H. Chiang, and H.-J. Li. Performance analysis of two-branch transmit diversity block-coded OFDM systems in time-varying multipath Rayleigh-fading channels. *IEEE Trans. Veh. Technol.*, 54(1):136–148, Jan. 2005.
- [7] M. L. McCloud. Analysis and design of short block OFDM spreading matrices for use on multipath fading channels. *IEEE Trans. Commun.*, 53(4):656–665, Apr. 2005.

- [8] V. G. S. Prasad and K. V. S. Hari. Space-time block coded interleaved orthogonal frequency division multiplexing system. *Proc. IEEE International Conference on Personal Wireless Communications ICPWC 2002*, pages 66–70, Dec. 2002.
- [9] A. Stamoulis, Z. Liu, and G. B. Giannakis. Space-time block-coded OFDMA with linear precoding for multirate services. *IEEE Sign. Process.*, 50(1):119–129, Jan. 2002.
- [10] S. Suthaharan and A. Nallanathan. Space-time coded MIMO-OFDM for high capacity and high data-rate wireless communications over frequency selective fading channels. *Proc. 4th IEEE. International Workshop on Mobile and Wireless Communications Network MWCN 2002*, pages 424–428, Sept. 2002.
- [11] V. Tarokh, H. Jafarkhani, and A. R. Calderbank. Space-time block coding for wireless communications: performance results. *IEEE J. Select. Areas Commun.*, 17(3):451–460, Mar. 1999.
- [12] V. Tarokh, N. Seshadri, and A. R. Calderbank. Space-time codes for high data wireless communications: performance criterion and code construction. *IEEE Trans. Inform. Theory*, 44(2):744–765, Mar. 1998.
- [13] L. C. Tran, T. A. Wysocki, A. Mertins, and J. Seberry. *Complex orthogonal space-time processing in wireless communications*. Springer, New York, USA, Jan. 2006.
- [14] B. Vucetic and J. Yuan. *Space-time coding*. John Wiley & Sons, Hoboken, NJ., 2003.
- [15] J. Yue and J. D. Gibson. Performance of a space-time block coded OFDM system. *Conference Record of the 36th Asilomar Conf. Signals, Syst., Comput.*, 2:1862–1866, Nov. 2002.
- [16] S. Zhou, P. Xia, G. Leus, and G. B. Giannakis. Chip-interleaved block-spread CDMA versus DS-SS-CDMA for cellular downlink: a comparative study. *IEEE Trans. Wireless Commun.*, 3(1):176–190, Jan. 2004.