

Faculty of Engineering
Faculty of Engineering - Papers

University of Wollongong

Year 2006

Developments in Geotechnical and
Geo-environmental research in relation to
low-lying floodplain improvement, with
special reference to acidic soil
improvement

B. Indraratna*
M. Shahin‡

A. Golab†
C. Rujikiatkamjorn**

*University of Wollongong, indra@uow.edu.au

†University of Wollongong

‡University of Wollongong

**University of Wollongong, cholacha@uow.edu.au

This conference paper was originally published as Indraratna, B, Golab, AN, Shahin, M and Rujikiatkamjorn, C, Developments in Geotechnical and Geo-environmental research in relation to low-lying floodplain improvement, with special reference to acidic soil improvement, Proceedings of the International Environmental Expertise Forum, Tanta, Egypt, 2006 (CD-R).

This paper is posted at Research Online.

<http://ro.uow.edu.au/engpapers/193>

Developments in geotechnical and geo-environmental research in relation to low-lying floodplain improvement, with special reference to acidic soil remediation and construction of embankments

Buddhima Indraratna*, Alexandra Golab**, Mohamed Shahin** and Cholachat Rujikiatkamjorn**

*Professor of Civil Engineering & **Research Fellow
School of Civil, Mining and Environmental Engineering,
Faculty of Engineering, University of Wollongong,
Wollongong City, NSW 2522, Australia.

Abstract

In many countries, the ever-growing demand for housing and tourism in coastal regions has forced the development of low-lying estuarine floodplains and wetlands for major infrastructure including highways, railways, hotels and high rise apartments, and commercial buildings. The estuarine clays, often with high organic content, are usually characterised by very high settlement upon loading affecting the stability of all forms of infrastructure. In addition, pyrites and other sulphidic compounds that exist at shallow depths in these soils can oxidise to form sulphuric acid presenting a challenging environmental issue, which if not controlled can cause catastrophic damage to coastal aquaculture and agriculture industries.

In this Keynote presentation, the authors will present an overview of the Australian coastal experience, highlighting the geoenvironmental remediation methods tailored for acid soil conditions in estuarine soils, and demonstrating the geotechnical improvement of soft clays using prefabricated vertical drains (wick drains) with special reference to embankments. The manipulation of the groundwater table for submerging pyrites thereby preventing oxidation and methods of treatment of acidic groundwater will be presented. The improvement of the geotechnical behaviour of compressible clays by inducing pre-construction consolidation via wick drains with vacuum pressure will be elucidated, through the latest research developments employing both experimental and numerical techniques.

Introduction

In coastal Australia, the oxidation of sulphidic minerals (mostly pyrite) in low-lying clay (acid sulphate soils) causes acidity that affects more than three million hectares of land (White *et al.*, 1997). The occurrence of acid sulphate soils (ASS) is also well documented in the coastal regions of many countries in Southeast Asia, Africa and South America and the Netherlands. While under reducing conditions and inundated, sulphidic minerals are generally inert. However, when exposed to atmospheric oxygen (entrained through soil pores), pyrite oxidation occurs through a series of complex reactions and results in the formation of acidity and releases Fe^{2+} , SO_4^{2-} , and Al^{3+} (Dent, 1986). Some coastal soft clays are not only acidic due to pyrite but also compressible and contain a high organic content, which contributes to acidity by its own decay and provides the ideal environment for pyritic oxidising bacteria to grow. Hence, the disturbance and drainage of sulphidic soils causes acidification of groundwater and surface water, adversely affecting coastal aquaculture and agriculture industries. Also, items of civil infrastructure (e.g.

foundations, pipelines, culverts, bridge piers, floodgates, etc.), which are predominantly concrete and steel based, cannot be protected from rapid corrosion and sulphate attack unless the groundwater and soil acidity is neutralised.

The rapid development and associated urbanisation in the coastal areas of many countries including Australia have increased the demand for infrastructure development (e.g. transport systems) over highly compressible soils. This necessitates the utilisation of even the poorest of soft clays, therefore, in order to avoid excessive and differential settlement, it is essential to stabilise the existing soft clay foundations prior to construction. The application of preloading with prefabricated vertical drains (PVDs) can accelerate pre-construction consolidation and hence, the post-construction settlements can be less with regard to infrastructure. Preloading via PVDs is the most successful ground improvement technique for low-lying areas (Indraratna *et al.*, 1994; Indraratna *et al.*, 2005e). It involves loading of the ground surface to induce a greater part of the ultimate settlement that the ground is expected to experience after construction. Installation of vertical drains can significantly decrease the preloading period by decreasing the drainage path length in the radial direction, as the consolidation time is inversely proportional to the square of the length of the drainage path. Application of vacuum pressure with surcharge loading can further accelerate consolidation while reducing the required surcharge fill material without any adverse effects on the stability of an embankment built on soft clay (Jamiolkowski *et al.*, 1983; Chai *et al.*, 1995). The applied vacuum pressure generates negative pore water pressure, resulting in an increase in effective stress in the soil, which leads to accelerated consolidation (Chu *et al.*, 2000; Indraratna *et al.*, 2005c). In addition, this method does not require the addition of any chemical admixtures into the soft soil.

Acidic Soil Remediation Techniques

Throughout Australia, large-scale flood mitigation works (i.e. surface drains and floodgates) designed to remove excess surface water from low-lying floodplains have increased *in-situ* acid production and acid transport (White *et al.*, 1997). The lowering of the watertable by deep surface drains promotes oxygen infiltration into the pyritic layer, thus increasing acid production. The drains are commonly fitted with one-way floodgates that prevent tidal carbonate/bicarbonate buffering of the drains and thereby create reservoirs of acidic water (pH < 4.5) that discharge into waterways during low tide. As the groundwater becomes acidified and flows into adjacent waterways, reactions occur that produce more acidity and consume oxygen. The resultant low dissolved oxygen levels and elevated levels of Al and Fe in the waterways are toxic to aquatic organisms through asphyxiation and clogging of gills. High Al and Fe concentrations in groundwater restrict plant growth and promote the growth of acid-tolerant species, thus reducing grazing areas for cattle. When ASS are exposed at the ground surface, large bare acid 'scalds' can exist. In these areas, a few plants survive and surface cracking enhances oxygen transport. Similarly, soil consolidation causes water-logging and reduces plant growth and grazing area. As a result, the existence of acid sulphate soils severely limits productivity in dairy farming, aquaculture and other agriculture along the coastal belt of Australia. Anthropogenic structures are also affected by acid sulphate soil leaching. Iron precipitates can clog pipes and drains, and acidic drainage can cause a build-up of minerals that are associated with the breakdown of concrete structures. The acid corrodes concrete and steel aquatic infrastructure, which is why costly sulphate resistant concrete and galvanised steel are required in many coastal areas of Australia. Finally, ASS have a low bearing capacity due to their gelatinous structure and building foundations often require extensive reinforcements.

Several acid sulphate soil remediation techniques have been used in coastal lowland in south-eastern NSW, Australia. Two main options exist to improve acid sulphate soils and more details will be given for each option in the following paragraphs:

- (1) Prevent the formation of acidic leachate by manipulating the watertable and hence preventing further pyrite oxidation. This can be achieved using weirs or modified floodgates; or
- (2) Remediate the acidic groundwater using either an impermeable lime barrier or a permeable reactive barrier.

Watertable Manipulation

Following initial research at the University of Wollongong, Indraratna *et al.* (1995) concluded that deep flood mitigation drains are responsible for lowering the watertable, hence, promoting sub-surface pyrite oxidation by entrainment of atmospheric oxygen. They suggested that simple v-notch weirs would reduce acid production by maintaining the watertable above the pyritic zone. Blunden and Indraratna (2001) developed an analytical model for in-situ pyrite oxidation and incorporated this in a finite element model to demonstrate more than 50% decrease in pyrite oxidation with the installation of v-notched weirs in a flood mitigation drain. Following extensive monitoring and finite element modelling of groundwater conditions and quality, fixed level v-notch weirs were installed at three elevations to maintain elevated groundwater levels. The weirs successfully maintained the watertable level above the acid sulphate soils (Figure 1), preventing additional pyrite oxidation, and reduced the rate of discharge of acid to the drain (Indraratna *et al.*, 2005a).

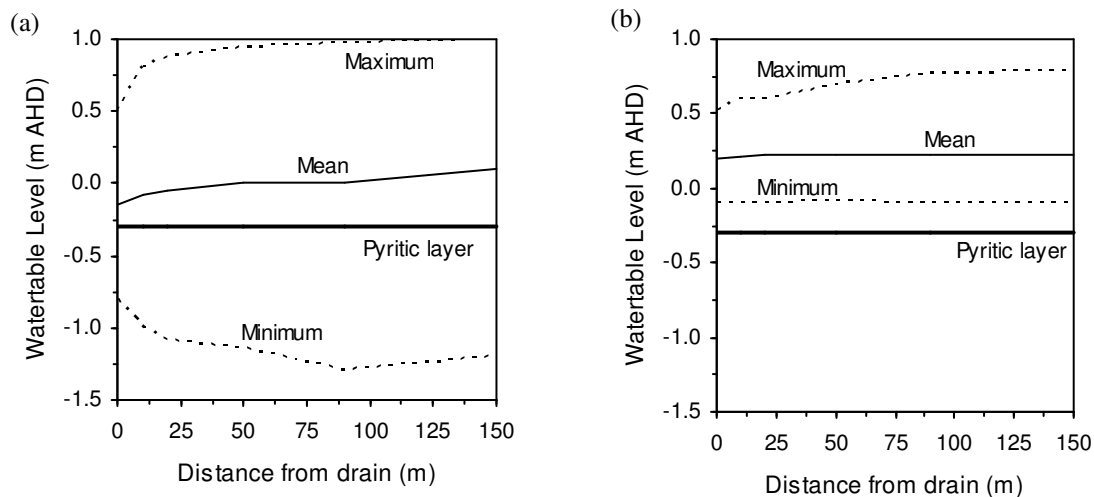

Figure 1: Average watertable level with respect to the pyritic layer with the maximum and minimum watertable level dashed (a) before and (b) after weir installation (modified after Indraratna *et al.*, 2005a).

Weirs work best in areas with good drainage and a watertable that is not too close to the ground surface but in low-lying areas with poor drainage, weirs elevate the risk of flooding. As an alternative solution, Glamore and Indraratna (2004) designed 2-way fully automated modified floodgates (smart gates) to buffer the acidic drain water with brackish river water. These smart gates were developed to open and close according to the quality of the drain water, thus allowing the ingress of brackish river water when the drain water

pH decreased below a threshold of 5. Following extensive monitoring and finite element based geochemical modelling, the smart gates were installed. The modified floodgates were successful in buffering the drain water pH before discharging the drain water into adjacent waterways (Indraratna *et al.*, 2005a). The advantage of this technique is that it prevents the release of large slugs of acidic water at low tide. The smart gates also open and close according to the water level in the drain and thus can be programmed to maintain the drain water level above the pyritic layer to prevent further pyrite oxidation. Numerical analysis based on FEM was extended to illustrate that saline intrusion into the surrounding soil (as a result of tidal ingress and acid buffering in the drains) was not a major concern for the pastureland or other agricultural activities. Sampling of the groundwater adjacent to the drain confirmed this analysis (Indraratna *et al.*, 2005a).

Groundwater Remediation

Although the weirs and 2-way floodgates are successful in decreasing pyrite oxidation by maintaining higher drain and groundwater levels (Glamore and Indraratna, 2004; Indraratna *et al.*, 2005a), their installation at low floodplain elevations is not only impractical but will also considerably increase the risk of flooding. In addition, a large store of acid exists in the soil that was generated in the past and continues to form due to bacterial oxidation which produces acid even under anaerobic and submerged conditions. This process is similar to that which causes acid drainage in some mines and tailings dams under reducing conditions (Benner *et al.*, 2000). The weirs and modified floodgates are able to prevent further oxidation of pyrite but cannot remediate the existing acidity that is stored in the soil (Indraratna *et al.*, 2005a). Considering both these points, the best solution for strategic low-lying locations is the direct treatment of acidic groundwater through the use of alkaline barriers, such as horizontal alkaline barriers and vertical permeable reactive barriers.

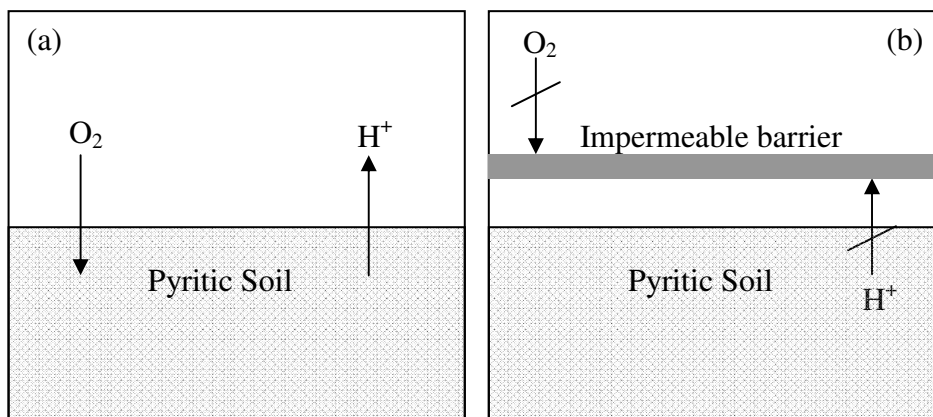

Figure 2: Schematic of (a) pyritic soil being oxidised by oxygen and releasing acidity into the groundwater and (b) an impermeable horizontal alkaline barrier that prevents the infiltration of oxygen into the pyritic soil and neutralises acidity in the groundwater.

Knowing that anaerobic oxidation of pyrite can be prevented if the pH is raised (e.g. Jaynes *et al.*, 1984), Indraratna *et al.* (2006) designed a horizontal alkaline barrier to remediate leachate from acid sulphate soils and prevent further pyrite oxidation (Figure 2). In low-lying areas, a shallow pyritic layer commonly exists that is at risk of oxidation, hence a horizontal alkaline barrier was designed that would be installed above the pyritic

layer by radial grouting. The main objective of the barrier is to (a) stop infiltration of oxygen to the pyritic layer and (b) neutralise any acidity stored in the soil. Two fine-grained alkaline materials, lime and fly ash, were mixed with water to form an ideal slurry and the optimum depth and pressure of injection were experimentally determined. For the large-scale field trial of the technique, the slurry was injected into a systematic grid of 22 holes to form the reactive barrier. The barrier successfully increased the pH (3.25 before and 4.6 after barrier installation) and decreased the concentration of aluminium (65.5 mg/L before and 20.3 mg/L after barrier installation) and iron (161 mg/L before and 42 mg/L after barrier installation) in the groundwater. A low ratio of Cl/SO_4 in groundwater indicates that pyrite oxidation is ongoing (Mulvey, 1993) and it increased after the barrier was installed which confirms that the barrier successfully controlled subsequent pyrite oxidation in the soil (Indraratna *et al.*, 2006).

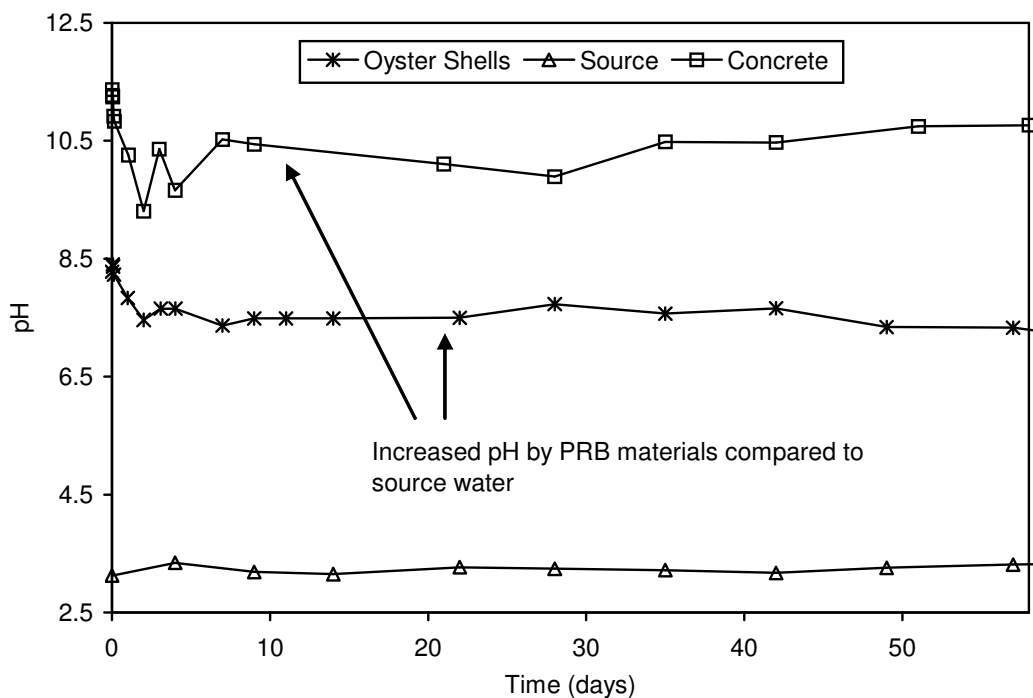

Figure 3: Performance of oyster shells and recycled concrete in column tests with acidic water over a period of 58 days. (The source water flowing into the columns and the effluent flowing out of the columns are displayed. Note the neutralising ability of both materials).

A permeable reactive barrier (PRB) typically consists of a trench filled with reactive materials (Figure 4). The barrier intersects the flow-path of a contaminant plume and ameliorates the contaminated groundwater through physical, chemical and/or biological processes, including precipitation, sorption, and oxidation/reduction. In the case of ASS landscapes, when acidic water comes into contact with the PRB, the acid will be neutralised by the alkaline reactive materials. In addition, the aluminium and iron will precipitate out of solution in the PRB because the solubility of both cations is pH dependent. PRBs have been used worldwide for the remediation of various contaminated sites, but their application for remediating ASS problems is very limited to date, except for one trial reported by Waite *et al.* (2002). The selection process for reactive materials to be used in the PRB is very important and depends on the type and concentration of contaminants (Gavaskar *et al.*, 1998). For the PRB for remediating ASS leachate, a variety

of reactive materials were tested, as described by Golab *et al.* (2006). The materials that were selected for use in the PRB are recycled concrete and oyster shells. Column tests of both materials have shown that they successfully neutralise the acidity in the groundwater (Figure 3) and remove the Al (e.g. 45 mg/L decreased to 0.05 mg/L) and Fe (e.g. 12 mg/L decreased to 0.04 mg/L) from the groundwater. A PRB composed of recycled concrete aggregates and oyster shells is currently being installed. One main advantage of PRBs in relation to automated floodgates and tilting weirs is that they cost much less, require no energy input and do not disrupt the existing land use.

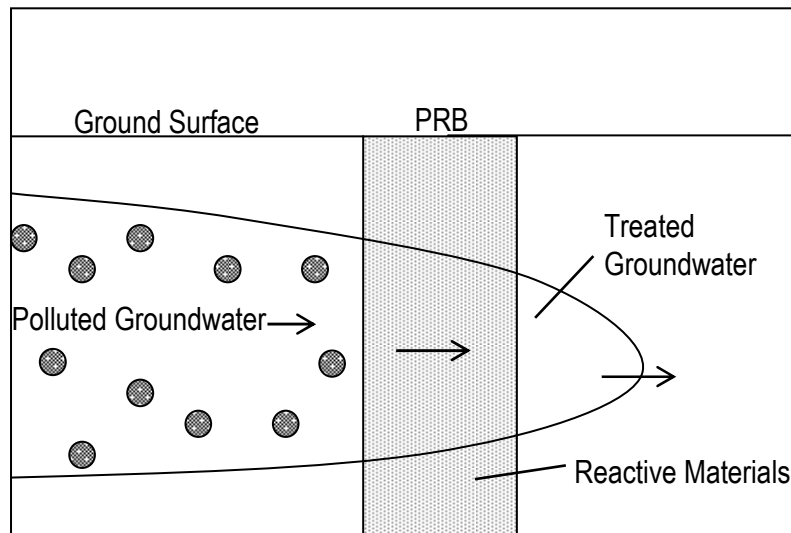

Figure 4: Schematic of a permeable reactive barrier intercepting a plume of contaminated groundwater.

Having improved the estuarine coastal soils in terms of acidity using the techniques detailed, the bearing capacity of the soils must be improved, hence the need for vertical drains, as described in the next section. Vertical drains will consolidate the soil, thereby compressing it. As a result the pyritic layer will be pushed lower, making it more likely to be submerged beneath the watertable at most times of the year. Also, the consolidation will decrease the porosity of the ASS, making it more difficult for oxygen to infiltrate into the pyritic layer. Together, these will lead to less oxidation and hence less production of acidity.

Soft Soil Improvement by Prefabricated Vertical Drains (PVDs)

Due to the rapid growth of infrastructure in coastal regions of many countries including Australia, it is highly likely that construction of embankments will be required on soft clays of high compressibility and low bearing capacity. The quality of robust constructions is defeated if the underlying soft soil is weak and compressible, thereby leading to unacceptable differential settlement. In this context, pre-construction soft clay improvement is imperative, and the application of preloading over unconsolidated soft soil is regarded as one of the classical and popular methods in practice. However, in the case of thick soil deposits with low permeability, the consolidation time is considerable; thus, a system of prefabricated vertical drains (PVDs) is often introduced to achieve accelerated radial drainage and consolidation. Installation of vertical drains can significantly reduce the preloading period by decreasing the drainage path in the radial direction. Current PVDs have a rectangular section, typically 100 × 5 mm, and are manufactured in long,

thin strips or bands. They are geocomposite and consist of a plastic core with grooves, studs or channels that are surrounded by a filter, most commonly made of a non-woven geotextile. The installation of PVDs is conducted by pushing a steel mandrel into the clay layer down to the desired depth. The use of PVDs prior to construction is now encouraged in many coastal areas in Australia. Pre-construction consolidation of soft clays will eliminate excessive post-construction settlement as well as increasing the shear strength of the soil. Moreover, the PVDs will continue to function in the long-term to provide rapid pore pressure dissipation, especially in low-lying central areas subjected to high annual rainfall.

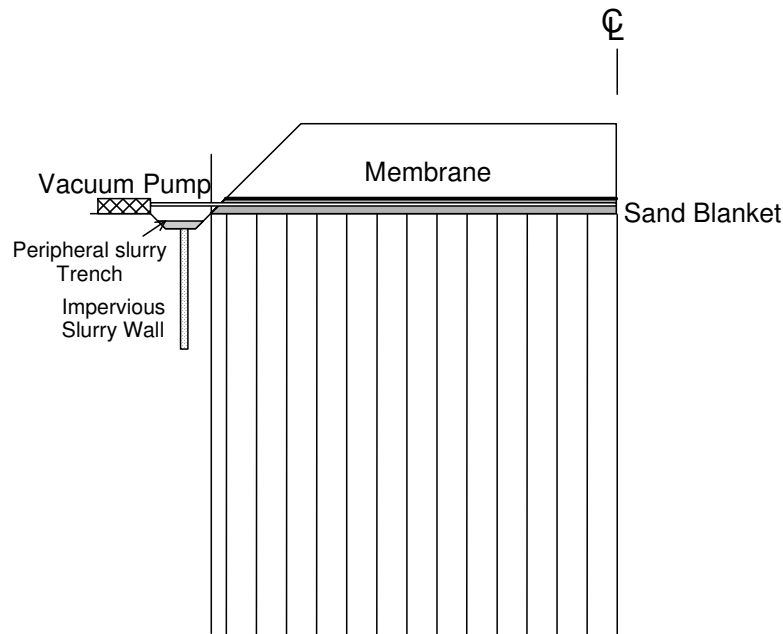

Figure 5: PVDs incorporating a preloading system (after Indraratna *et al.*, 2005b).

Pre-consolidation of soft clays by applying a surcharge load alone will take too long for urgent infrastructure developments. When a higher surcharge load is required to meet the expected settlement and surcharging becomes expensive, the application of vacuum pressure with reduced surcharge loading can be used. In this method, an external negative load is applied to the soil surface in the form of vacuum pressure through a sealed membrane system. A higher effective stress is achieved by readily decreasing the pore water pressure, while the total stress remains the same, thus, any risk of potential shear failure due to excess pore pressure can be eliminated. Figure 5 shows a typical vacuum preloading layout incorporating a PVD arrangement (Indraratna *et al.*, 2005b). For a PVD system incorporating vacuum preloading, the installation of some horizontal drains in the transverse and longitudinal direction is usually required after installing the sand blanket. Subsequently, these drains can be connected to the edge of a peripheral bentonite slurry trench, which is typically sealed by an impervious geomembrane. The trenches can then be filled with water to improve sealing between the membrane and the bentonite slurry. Vacuum pumps are connected to the prefabricated discharge system extending from the trenches, and the suction head generated by the pump accelerates dissipation of excess pore water pressure in the soil towards the drains and the surface.

Laboratory Testing using Large-scale Consolidometer

In order to study the consolidation behaviour of soft clays stabilised by PVDs, a large-scale radial drainage consolidometer was designed and installed at the University of Wollongong (Indraratna and Redana, 1995). This apparatus, as shown in Figure 6, consists of two half sections made of stainless steel. The internal diameter and the height of the cell are 450 mm and 950 mm, respectively. The loading system with a maximum capacity of 1200 kN is applied by an air jack compressor system via a piston. The settlement is measured by a displacement transducer placed at the top of this piston and several pore pressure transducers have been installed to measure the excess pore water pressure at various points. Details about the equipment and testing procedures are given by Indraratna and Redana (1995). Figure 7 shows the results of the large-scale consolidometer that represent the typical time-settlement curves for soft clays improved by three different methods: (a) surcharge alone, (b) PVDs with surcharge and (c) PVDs with vacuum preloading. It can be seen that the required consolidation time is shorter when the clay is improved by PVDs, whereas consolidation behaviour occurs more gradually in the case of surcharge alone (without PVDs). In terms of pore pressure dissipation, the initial excess pore pressure generated by vacuum application is smaller than that generated by conventional surcharge pressure (Figure 8). When vacuum pressure is applied, the ultimate excess pore pressure is always negative, significantly increasing the effective stress inducing consolidation. In the case of vacuum application, it is important to ensure that the site is totally sealed and isolated from any surrounding permeable soils to avoid air leakage that adversely affects the vacuum efficiency.

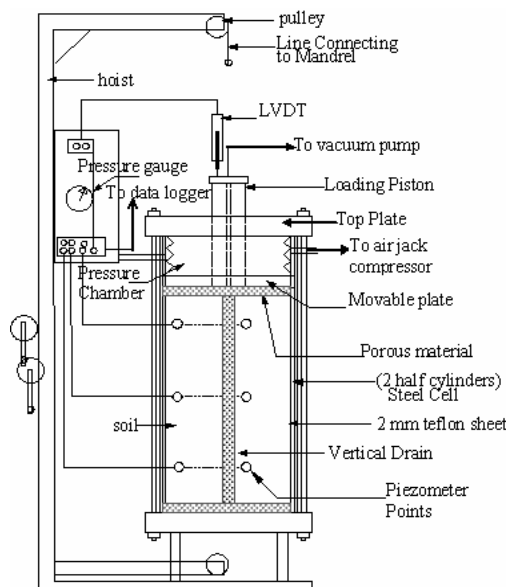

Figure 6. Schematic diagram of a large-scale radial drainage consolidometer (after Indraratna and Redana, 1995)

Numerical Modelling of Soft Soil Radial Consolidation Subjected to Vacuum Preloading

In practice, clay foundations usually have a large number of vertical drains underneath the embankment. In such cases, *equivalent* plane strain modelling is a better approach for numerical finite element method (FEM) prediction, whereby all drains in a row are merged together as a ‘continuous drain wall’. This allows the numerical

computation to be more feasible and time efficient from a convergence point of view. For a multi-drain simulation, the plane strain analysis can be employed to most field situations (Hansbo, 1981; Hird *et al.*, 1992; Indraratna and Redana, 2000; Indraratna *et al.*, 2004). Nevertheless, realistic field predictions require the axisymmetric properties to be correctly converted to an *equivalent* 2D plane strain condition, especially with regard to the soil permeability coefficients and the vertical drain geometry (Indraratna and Redana, 1997). Details regarding the equivalent plain strain model can be found in Indraratna *et al.* (2005c). In this section, the equivalent plane strain model for radial consolidation and vacuum surcharge proposed by Indraratna *et al.* (2005f) is applied to two embankments stabilised with vertical drains subjected to vacuum loading in Thailand. The predicted settlements, pore pressures and lateral displacements are compared with the field measurements.

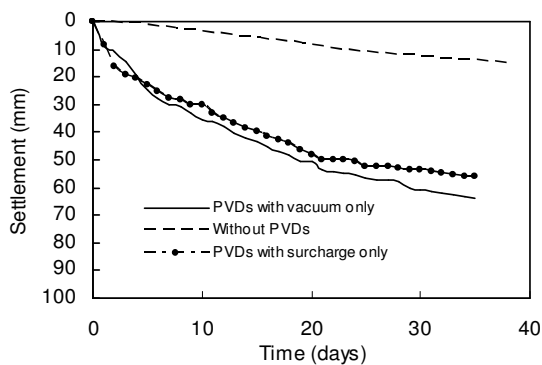

Figure 7. Pre-consolidation settlements

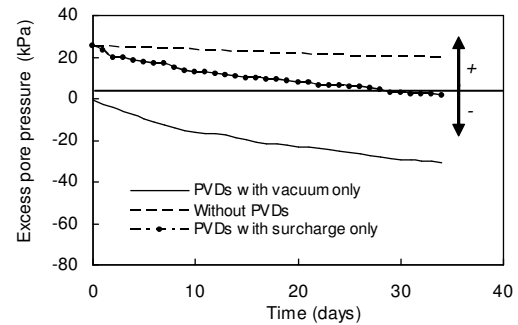

Figure 8. Time-dependent excess pore water pressure dissipation

The Second Bangkok International Airport is located in Samutprakan Province, about 30 km east of the capital city, Bangkok. The subsoil layer at this site is composed of a thick soft clay deposit. Ground improvement with prefabricated vertical drains has been applied successfully by using a conventional sand surcharge load (Indraratna and Redana, 2000). Since this site is located far from the source of surcharge material, the use of vertical drains incorporating vacuum preloading was introduced as an alternative to reduce the amount of fill material required for embankment construction at this site.

One test embankment, TV1 (Figure 9), was constructed on soft Bangkok clay with PVDs. The total base area of each embankment is 40 m × 40 m (AIT, 1995). In embankment TV1, 15 m long PVDs with hypernet drainage systems were used. The drainage blanket which serves as a working platform was constructed with a thickness of 0.3 m. A water- and air-tight geomembrane liner was placed on top of the drainage system. The geomembrane liner was sealed by placing it against the edges of the bottom of the perimeter trench and covered with a 300 mm bentonite seal and submerged under water. The PVDs were installed in a triangular pattern with 1 m spacing. The parameters of the PVDs are listed in Table 1. Surface settlement plates, subsurface multipoint extensometers, vibrating wire electrical piezometers, and inclinometers were installed to monitor the behaviour of the embankments. At the dummy area, observation wells and standpipe piezometers were also installed.

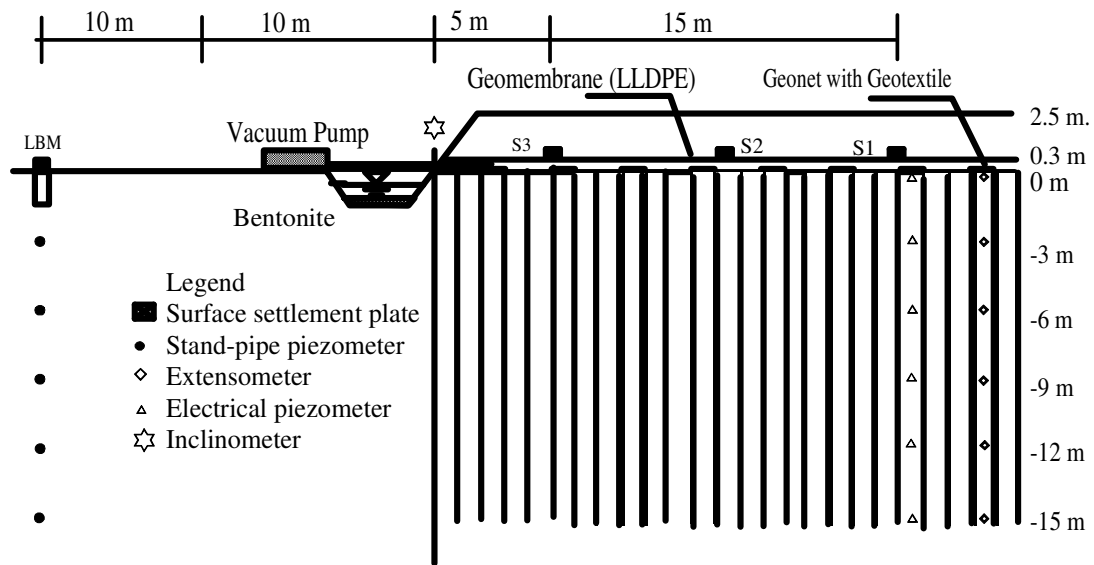

Figure 9. Crosssection of embankment TV1 and location of monitoring system (after Indraratna *et al.*, 2005f).

Table 1: Vertical drain parameters

Spacing, s	1.0 m (triangular)
Diameter of drain, d_w	50 mm
Diameter of smear zone, d_s	300 mm
Ratio of k_t/k'_h	10
Length of vertical drain	15 m
Discharge capacity, q_w	50 m ³ /year (per drain)

A vacuum pump capable of generating 70 kPa suction pressure was employed. After 45 days of vacuum pressure application, the embankment load was applied in 4 stages up to a height of 2.5 m (the unit weight of surcharge fill equals to 18 kN/m³). The stages of loading for the embankment are illustrated in Figure 10. The settlement, excess pore water pressure and lateral movement were monitored for about 150 days.

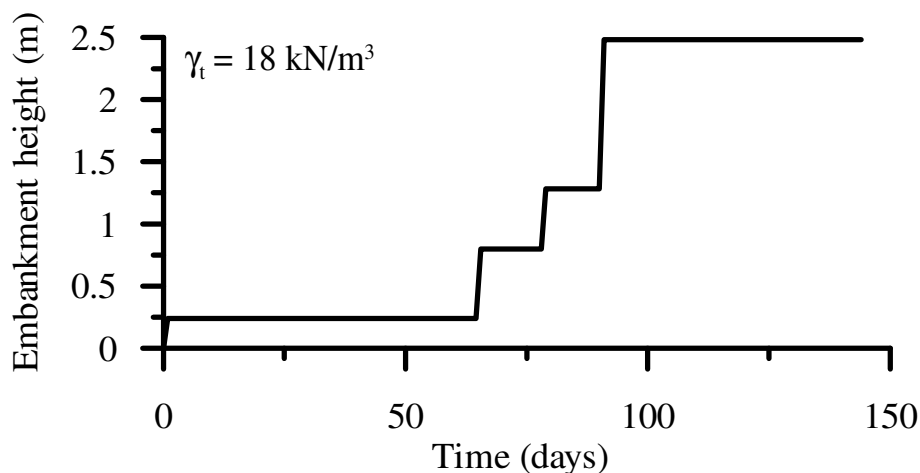

Figure 10. Multistage loading for embankment TV1 (modified after Indraratna *et al.*, 2005b).

The numerical analysis was based on the modified Cam-Clay model (Roscoe and Burland, 1968) and the equivalent plane strain procedure developed by Indraratna *et al.* (2005d), which are incorporated in the finite element code, ABAQUS. The adopted parameters of 5 subsoil layers are listed in Table 2. According to the laboratory tests conducted by Indraratna and Redana (1998), the ratio between horizontal and vertical permeability within the smear zone was set to 1. Outside the smear zone, the horizontal permeability was taken to be double that of the vertical permeability. The equivalent permeability inside and outside the smear zone was calculated using the equivalent strain simulation (Indraratna *et al.*, 2005d).

Table 2. Modified Cam-Clay parameters (after Indraratna *et al.*, 2005f).

Depth m	λ	κ	ν	e_0	γ kN/m ³	k_v 10 ⁻⁹ m/s	k_h 10 ⁻⁹ m/s	k'_h 10 ⁻⁹ m/s	k_{hp} 10 ⁻⁹ m/s	k'_{hp} 10 ⁻⁹ m/s
0.0-1.0	0.3	0.03	0.3	1.8	16	15.1	30.1	15.1	9.0	3.45
1.0-8.5	0.7	0.08	0.3	2.8	15	6.4	12.7	6.4	3.8	1.46
8.5-10.5	0.5	0.05	0.25	2.4	15	3.0	6.0	3.0	1.8	0.69
10.5-13	0.3	0.03	0.25	1.8	16	1.3	2.6	1.3	0.8	0.30
13-15	1.2	0.1	0.25	1.2	18	0.3	0.6	0.3	0.2	0.07

The finite element mesh, which contains 8-node bi-quadratic displacement and bilinear pore pressure elements, is shown in Figure 11. Because of symmetry, it was sufficient to consider one half of the embankment for the numerical analysis. For the area with PVDs and smear zones, a finer mesh was employed so that each unit cell represents a single drain and the smear zone on either side of the drain. The finer mesh also prevents unfavorable aspect ratios of elements. The embankment loading was simulated by applying incremental vertical loads to the upper boundary. The following 4 distinct models were numerically examined under the 2D multi-drain analysis (Indraratna *et al.*, 2005e):

- Model A: Conventional analysis (i.e. no vacuum application);
- Model B: Vacuum pressure varies according to field measurement and decreases linearly to zero at the bottom of the drain;
- Model C: No vacuum loss (i.e. -60 kPa vacuum pressure was kept constant after 40 days), vacuum pressure diminishes to zero along the drain length; and
- Model D: Constant time-dependent vacuum pressure throughout the soil layer.

All above models included the smear effect but neglected well resistance as previous studies indicated that well resistance was not significant for drain lengths shorter than about 20 m (Indraratna and Redana, 2000).

Figure 12 compares predicted and measured surface settlement. Model B predictions agree with the field data. Comparing all the different vacuum pressure conditions, Models A and D give the lowest and highest settlement, respectively. A vacuum application combined with a PVD system can accelerate the consolidation process significantly. With vacuum application, most of the primary consolidation is achieved around 120 days, whereas conventional surcharge (same equivalent pressure) requires more time to complete primary consolidation (after 150 days). It is also apparent that a greater settlement can be obtained, if any loss of vacuum pressure can be minimised (Model C).

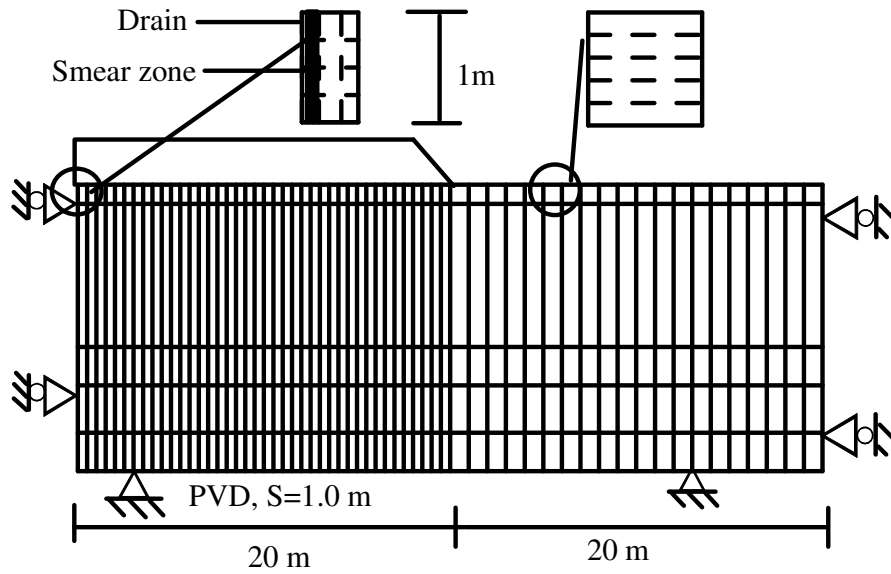

Figure 11: Finite element mesh for plane strain analysis (Indraratna *et al.*, 2005f).

Figure 13 illustrates the predicted and measured excess pore pressures. The field observations are closest to Model B, implying that the writers assumption of linearly decreasing time-dependent vacuum pressure along the drain length is justified. Excess pore pressure generated from the vacuum application is less than the conventional case, which enables the rate of construction of an embankment to be higher than conventional construction.

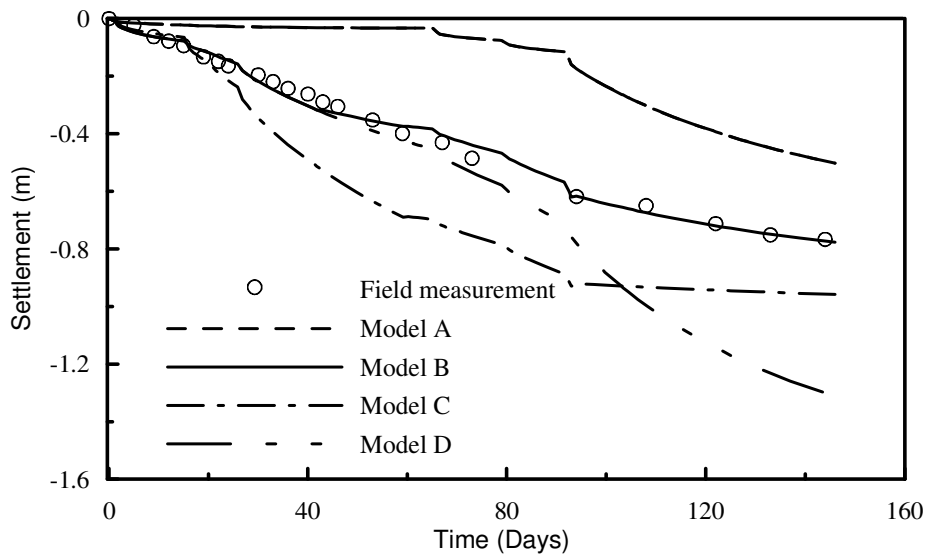

Figure 12. Surface settlement time curves (modified after Indraratna *et al.*, 2005b).

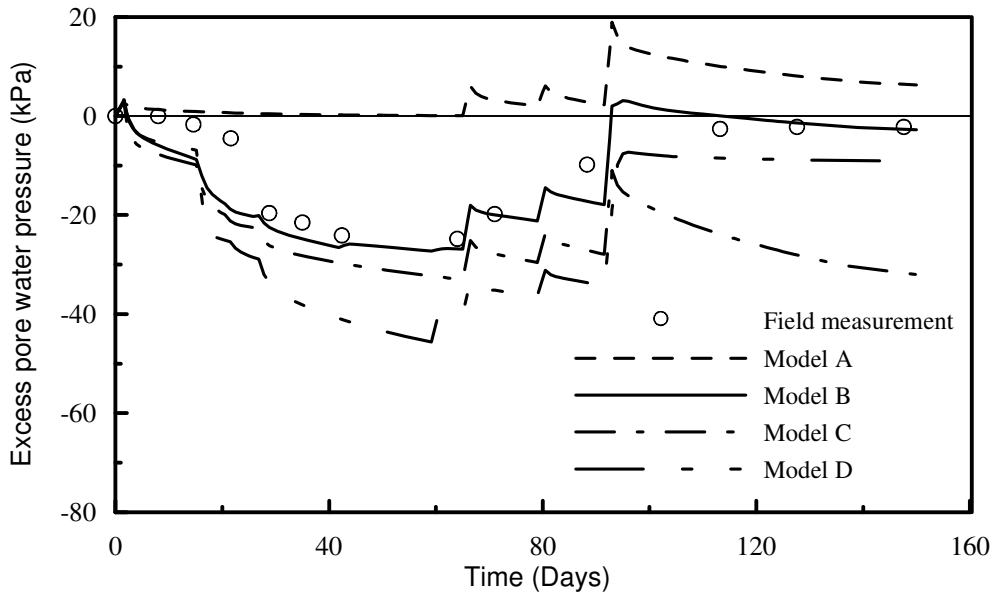

Figure 13. Variation of excess pore water pressure 3 m deep below the surface and 0.5 m away from centreline (modified after Indraratna *et al.*, 2005b).

The predicted and measured lateral displacements (at the end of embankment construction) are shown in Figure 14. The observed lateral displacements do not agree well with all vacuum pressure models. In the middle of the very soft clay layer (4-5 m deep), the predictions from Models B and C are closest to the field measurements. Nearer to the surface, the field observations do not agree with the ‘inward’ lateral movements predicted by Models B and C. The discrepancy between the finite element models and the measured results is more evident in the topmost weathered crust (0-2 m).

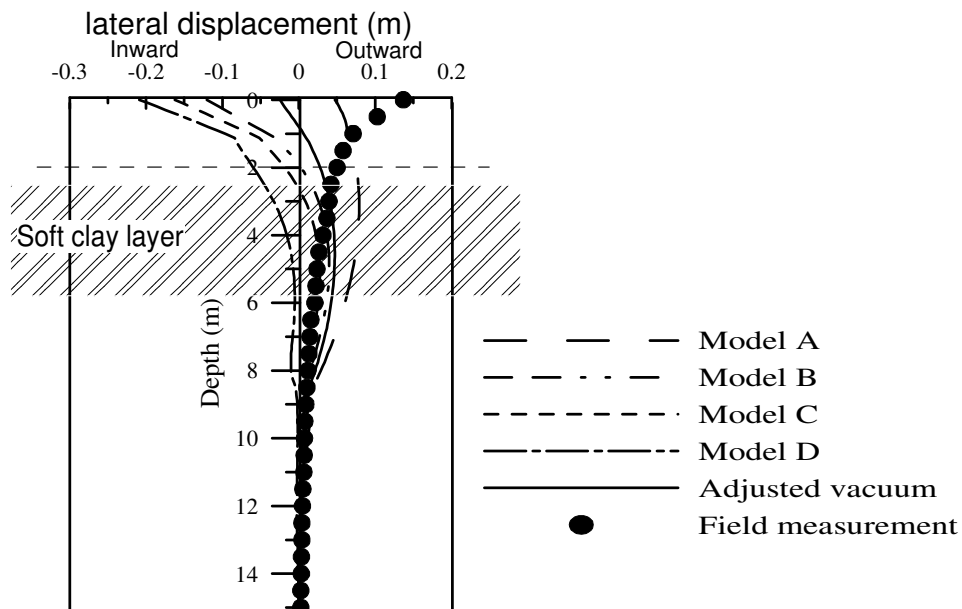

Figure 14: Distribution with depth of calculated and measured lateral displacements (modified after Indraratna *et al.*, 2005b).

Conclusions

Acidic (sulphidic) soft clays are a major problem in terms of environmental acidification and damage to civil infrastructure. The problem was exacerbated by the installation of deep drains through the sulphidic clays and the fitting of one-way floodgates onto the drains. Several remediation techniques exist to deal with this problem. One option is to alter the level of the watertable and therefore prevent the formation of acidity. Watertable manipulation can be achieved through the use of weirs or modified floodgates that allow exchange between the drain and the adjacent waterway. The modified floodgate also allows the buffering of acidity in the drain through the ingress of brackish river water. Another option is to remediate the acidic groundwater through the use of a reactive barrier. Groundwater remediation can be achieved through the use of an alkaline horizontal barrier or a vertical permeable reactive barrier.

It is evident that soft soil stabilisation using a system of vacuum-assisted consolidation via PVDs is a useful and practical approach for accelerating radial consolidation. Such a system reduces the need for a high surcharge load, as long as air leaks can be eliminated in the field. However, accurate modelling of vacuum preloading requires laboratory and field studies to investigate the exact nature of vacuum pressure distribution within a given soil formation and PVD system. In addition, a resilient system is required to prevent air leaks that can reduce the desirable negative pressure (suction) with time.

References

- AIT, 1995. The Full Scale Field Test of Prefabricated Vertical Drains for The Second Bangkok International Airport (SBIA), AIT, Bangkok, Thailand.
- Benner, S.G., Gould, W.D. and Blowes, D.W., 2000. Microbial populations associated with the generation and treatment of acid mine drainage. *Chemical Geology*, 169(3-4): 435-448.
- Blunden, B. and Indraratna, B., 2001. Pyrite oxidation model for assessing ground-water management strategies in acid sulfate soils. *Journal of Geotechnical and Geoenvironmental Engineering, ASCE*, 127(2): 146-157.
- Chai, J.C., Miura, N., Sakajo, S. and Bergado, D.T., 1995. Behavior of vertical drain improved subsoil under embankment loading. *Journal of Soil and Foundations, Japanese Geotechnical Society*, 35(4): 49-61.
- Chu, J., Yan, S.W. and Yang, H., 2000. Soil improvement by the vacuum preloading method for an oil storage station. *Geotechnique*, 50(6): 625-632.
- Dent, D., 1986. Acid Sulphate Soils: a baseline for research and development, *IRRI Publication No. 39*. Wageningen, the Netherlands.
- Gavaskar, A.R., Gupta, N., Sass, B.M., Janosy, R.J. and O'Sullivan, D., 1998. *Permeable Barriers for Groundwater Remediation: Design, Construction, and Monitoring*. Battelle Press, Columbus, 176 pp.
- Glamore, W. and Indraratna, B., 2004. A two-stage decision support tool for restoring tidal flows to flood mitigation drains affected by acid sulphate soil: case study of Broughton Creek Floodplain, New South Wales, Australia. *Australian Journal of Soil Research*, 42: 639-648.
- Golab, A.N., Peterson, M.A. and Indraratna, B., 2006. Selection of potential reactive materials for a permeable reactive barrier for remediating acidic groundwater in acid sulphate soil terrains. *Quarterly Journal of Engineering Geology and Hydrogeology*, (in press).

- Hansbo, S., 1981. Consolidation of fine-grained soils by prefabricated drains, *Proceedings of 10th International Conference on Soil Mechanics and Foundation Engineering*. Stockholm, Balkema, Rotterdam, pp. 677-682.
- Hird, C.C., Pyrah, I.C. and Russell, D., 1992. Finite element modelling of vertical drains beneath embankments on soft ground. *Geotechnique*, 42(3): 499-511.
- Indraratna, B., Balasubramaniam, A.S. and Ratnayake, P., 1994. Performance of embankment stabilized with vertical drains on soft clay. *Journal of Geotechnical and Geoenvironmental Engineering ASCE*, 120(2): 257-273.
- Indraratna, B., Bamunawita, C. and Khabbaz, H., 2004. Numerical modeling of vacuum preloading and field applications. *Canadian Geotechnical Journal*, 41: 1098-1110.
- Indraratna, B., Golab, A., Glamore, W. and Blunden, B., 2005a. Acid sulphate soil remediation techniques on the Shoalhaven River Floodplain, Australia. *Quarterly Journal of Engineering Geology and Hydrogeology*, 38: 129-142.
- Indraratna, B., Golab, A.N. and Banasiak, L.J., 2006. Installation of a lime injection barrier for the remediation of acid sulphate soil problems. *Quarterly Journal of Engineering Geology and Hydrogeology*, (under review).
- Indraratna, B. and Redana, I.W., 1995. Large-scale, radial drainage consolidometer with central drain facility. *Australian Geomechanics Journal*, 29: 103-105.
- Indraratna, B. and Redana, I.W., 1997. Plane strain modeling of smear effects associated with vertical drains. *Journal of Geotechnical and Geoenvironmental Engineering ASCE*, 123(5): 474-478.
- Indraratna, B. and Redana, I.W., 1998. Laboratory determination of smear zone due to vertical drain installation. *Journal of Geotechnical and Geoenvironmental Engineering ASCE*, 125(1): 96-99.
- Indraratna, B. and Redana, I.W., 2000. Numerical modeling of vertical drains with smear and well resistance installed in soft clay. *Canadian Geotechnical Journal*, 37: 132-145.
- Indraratna, B., Rujikiatkamjorn, C., Balasubramaniam, A.S. and Wijeyakulasuriya, V., 2005b. Predictions and observations of soft clay foundations stabilized with geosynthetic drains and vacuum surcharge. In: B. Indraratna and J. Chu (Editors), *Ground Improvement - Case Histories Book (Volume 3)*. Elsevier, London, pp. 199-230.
- Indraratna, B., Rujikiatkamjorn, C. and Sathananthan, I., 2005c. Analytical modeling and field assessment of embankment stabilized with vertical drains and vacuum preloading. In: 16th ICSMGE committee (Editor), *The Proceedings of the 16th International Conference on Soil Mechanics and Geotechnical Engineering*. Osaka, Japan, Millpress, Rotterdam, the Netherlands, pp. 1049-1052.
- Indraratna, B., Rujikiatkamjorn, C. and Sathananthan, I., 2005d. Radial consolidation of clay using compressibility indices and varying horizontal permeability. *Canadian Geotechnical Journal*, 42: 1330-1341.
- Indraratna, B., Rujikiatkamjorn, C., Sathananthan, I., Shahin, M.A. and Khabbaz, H., 2005e. Analytical and numerical solutions for soft clay consolidation using geosynthetic vertical drains with special reference to embankments, *The Fifth International Geotechnical Engineering Conference*. Cairo, Egypt, pp. 55-86.
- Indraratna, B., Sathananthan, I., Rujikiatkamjorn, C. and Balasubramaniam, A.S., 2005f. Analytical and numerical modelling of soft soil stabilized by PVD incorporating vacuum preloading. *International Journal of Geomechanics*, 5(2): 114-124.
- Indraratna, B., Sullivan, J. and Nethery, A., 1995. Effect of groundwater table on formation of acid sulphate soils. *Minewater and the Environment*, 14: 71-84.

- Jamiolkowski, M., Lancellotta, R. and Wolski, W., 1983. Precompression and speeding up consolidation, *Proceedings of 8th European Conference on Soil Mechanics and Foundations*. Helsinki, Finland, pp. 1201-1206.
- Jaynes, D.B., Rogowski, A.S. and Pionke, H.B., 1984. Acid mine drainage from reclaimed coal strip mines 1. Model description. *Water Resources Research*, 21(2): 233-242.
- Mulvey, P., 1993. Pollution, prevention and management of sulfuric clays and sands. In: R. Bush (Editor), *Proceedings of the National Conference on Acid Sulfate Soils*. Coolangatta, Queensland, pp. 116-129.
- Roscoe, K.H. and Burland, J.B., 1968. On the generalized stress strain behavior of wet clay, *Engineering Plasticity*. Cambridge University Press, Cambridge, U.K., pp. 535-609.
- Waite, D.T., Desmier, R., Melville, M., Macdonald, B. and Lavitt, N., 2002. Preliminary investigation into the suitability of permeable reactive barriers for the treatment of acid sulfate soils discharge. In: D.L. Naftz, S.J. Morrison, C.C. Fuller and J.A. Davis (Editors), *Handbook of Groundwater Remediation Using Permeable Reactive Barriers: Applications to Radionuclides, Trace Metals, and Nutrients*. Academic Press, San Francisco, pp. 67-104.
- White, I., Melville, M.D., Wilson, B.P. and Sammut, J., 1997. Reducing acidic discharges from coastal wetlands in eastern Australia. *Wetlands Ecology and Management*, 5(1): 55-72.